

TOSHIBA

OWNER'S MANUAL

Video Cassette Recorder



M-261

SPECIALIZED
OPERATIONS

RECORDING 28

PLAYBACK 25

VIDEO CASSETTES 24

OPERATING
CONTROLS

16

FIRST-TIME
OPERATION

11

INSTALLATION

6

IMPORTANT
SAFEGUARDS

3

Safety Precautions

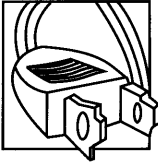

Your VCR operates on 120 volts, 60Hz (normal household current) and has a polarized plug. Because one blade of the plug is wider than the other, the plug fits into the wall socket only one way. Do not defeat the safety feature of this plug. If you need an extension, use a polarized cord.

Caution: To prevent electrical shock, do not use the polarized plug on this Video Cassette Recorder with an extension cord, receptacle, or other outlet unless the blades can be fully inserted to prevent blade exposure.

Mise en garde: Pour prévenir les chocs électriques, ne pas utiliser la fiche polarisée de cet appareil avec une rallonge, une prise de courant ou une autre sortie, à moins que les lames ne puissent être insérées à fond sans qu'aucune partie soit laissée à découvert.

WARNING: To prevent fire or shock hazard, do not expose this VCR to rain or moisture.

Illustrated below is the label on the back of your Video Cassette Recorder

	CAUTION RISK OF ELECTRIC SHOCK DO NOT OPEN		The symbol of a lightning flash within a triangle is intended to alert the user to the presence of uninsulated "dangerous voltage" within the product's enclosure that may be of sufficient magnitude to constitute a risk of electrical shock.
	AVIS RISQUE DE CHOC ÉLECTRIQUE NE PAS OUVRIR		An exclamation point within a triangle is intended to alert the user to the presence of important operating and maintenance(service) instructions in the literature accompanying the product.

Caution: To reduce the risk of electric shock, do not remove the cover or back. No user-serviceable parts are inside. If you spill liquid on the VCR, disconnect the power cord to prevent possible fire or shock hazard and consult authorized service personnel. Moisture can damage internal parts. Refer all service to Authorized TOSHIBA VCR Service center personnel only.

Caution: Maintain electrical safety. Powerline-operated equipment or accessories connected to this unit should bear the UL listing mark or CSA certification mark on the accessory itself and should not have been modified so as to defeat the safety feature. This will help avoid any potential hazard from electric shock or fire. If in doubt, contact qualified service personnel.

Note to Cable TV Installer :

This reminder is provided to call your attention to Article 820-40 of the National Electrical Code (Section 54 of Canadian Electrical Code, Part 1), that provides guidelines for proper grounding and, in particular, specifies that the cable ground shall be connected to the grounding system of the building as close to the point of cable entry as practical.

User Installer Caution:

Your authority to operate this FCC certified equipment could be voided if you make changes or modifications not expressly approved by this party responsible for compliance to part 15 FCC rules.

Caution: The unauthorized recording of television programs and other materials may infringe the rights of others.

Accessories

Check to make sure that you have all of the following accessories before disposing of the packing materials.

① Antenna Cable 	② Safety Instruction 	③ Remote Control Unit (Wireless) with two AAA batteries
---------------------	--------------------------	---

In the spaces provided below, record the Model and Serial No. located at the rear of your video cassette recorder.

Model No. M-261

Serial No. _____

Retain this information for future reference.

Using This Manual

Congratulations on your choice of a TOSHIBA M-261. You have selected a high-quality, precision-engineered instrument designed to give you years of video and audio enjoyment.

To get the best performance from your new VCR, it is important that you carefully read and follow the operating instructions in this manual in the sequence in which they are presented.

Should you experience a problem, please follow the "Trouble Checks" on page 41. The warranty describes what will be done for you should your new VCR need service during the warranty period. It also tells you how and from whom you should request service.

Table of Contents

Safety Precautions.....	1
Accessories.....	1

IMPORTANT SAFEGUARDS 3-5

GENERAL INSTALLATION INFORMATION Choosing a Location for Your VCR6

INSTALLATION	
TV Antenna and VCR Connections.....	7
VCR and TV Connections.....	8
CATV Connections.....	9-10

FIRST-TIME OPERATION	
Unpack the VCR and Accessories.....	11
Install the Batteries in the Remote Control.....	11
Connect an Antenna or Cable-TV System to the VCR.....	11
Set the CH3/CH4 Switch on the Back of the VCR to Select the "VCR Channel".....	11
Turn on the VCR and Select an Active Channel.....	12
Set the CATV.....	12
Learn How to Use the TV/VCR Button.....	12
Test the VCR Connections.....	12
Auto Channel Program Channels into Memory.....	13-14
Set the Clock.....	14
Make a Recording and Play It Back.....	15

VCR OPERATING CONTROLS	
VCR Jack Panels.....	16
VCR Operating Controls.....	17
VCR Display Panel.....	18
Remote Control Buttons that Control the VCR.....	19-20
Remote Control Buttons that Control a TV.....	21-22

VCR FEATURES	
Quick-Play Feature.....	23
Auto Head Cleaner.....	23
VCR Function Set Up Menu.....	23
Three Language Menus.....	23

VIDEO CASSETTES	
Tape Speed.....	24
Record Protect Tab.....	24
Inserting and Removing Cassettes.....	24
Cassette Care and Storage.....	24

PLAYBACK	
Playback Guide.....	25
Picture Search.....	26
Accel Search.....	26
Slow-Motion Playback.....	26
Still for Stop-Action Playback.....	26
Frame Advance.....	26
Tracking (Automatic and Manual).....	26
On-Screen Displays.....	27
Time Counter with Memory-Stop Feature.....	27

RECORDING	
Recording Guides.....	28
Tape Recording Speeds.....	28
Recording with TV Turned Off.....	28
Recording and Viewing the Same Program.....	29
Recording and Viewing Different Programs.....	29
One Touch Recording (OTR).....	30
Programming the Timer.....	31-33
Timer Recording.....	34
Recording from a Camcorder.....	35
Recording from another VCR.....	36

SPECIALIZED OPERATIONS	
Index.....	37
Index Register.....	37
Scan and Play (Index Playback).....	37
Skip Search (Index Playback).....	38
Remaining Tape Display Function.....	39
Copying VCR Recording Function.....	40

TROUBLE CHECKS	41
-----------------------------	----

CLEANING THE VCR	42
-------------------------------	----

DESIGN SPECIFICATIONS	42
------------------------------------	----

IMPORTANT SAFEGUARDS

CAUTION: PLEASE READ AND OBSERVE ALL WARNINGS AND INSTRUCTIONS GIVEN IN THIS OWNER'S MANUAL AND THOSE MARKED ON THE UNIT. RETAIN THIS BOOKLET FOR FUTURE REFERENCE.

This set has been designed and manufactured to assure personal safety. However, improper use can result in electrical shock or fire hazard. The safeguards incorporated in this unit will protect you if you observe the following procedures for installation, use and service. This unit is fully transistorized and does not contain any parts that can be repaired by the user.

DO NOT REMOVE THE CABINET COVER OR YOU MAY BE EXPOSED TO DANGEROUS VOLTAGES. REFER SERVICING TO QUALIFIED SERVICE PERSONNEL.

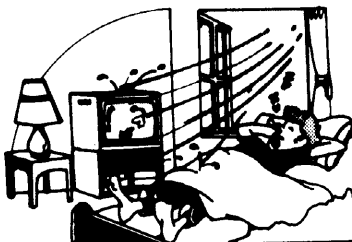
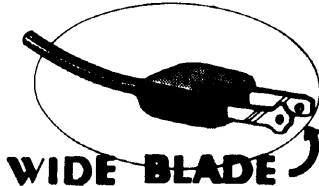

1. After unpacking this video product, read the owner's manual carefully and follow all the operating and other instruction.

2. This video product should be operated only from the type of power source indicated on the marking labels. If you are not sure of the type of power supply to your home, consult your sales person or your local power company. For video products intended to operate from battery power or other sources, refer to the operating instructions.

3. This video product is equipped with a polarized alternating current line plug (a plug having one blade wider than the other). This plug will fit into the power outlet only one way. This is a safety feature. If you are unable to insert the plug fully into the outlet, try reversing the plug. If the plug should still fail to fit, contact your electrician to replace your obsolete outlet. Do not defeat the safety purpose of the polarized plug.

4. Slots and openings in the cabinet are provided for ventilation and to ensure reliable operation of the video product and to protect it from overheating. These openings must not be blocked or covered. The openings should never be blocked by placing the video product on a bed, sofa, rug or other similar surface. This video product should never be placed near or over a radiator or heat register. This video product should not be placed in a built-in installation such as a bookcase or rack unless proper ventilation is provided or the manufacturer's instructions have been adhered to.

5. Do not expose this video product to rain or use near water. For example: near a bath tub, wash bowl, kitchen sink, laundry tub, in a wet basement, or near a swimming pool and the like.

6. Unplug the video product from wall outlet before cleaning. Use only a soft damp cloth and never use benzine, thinner or other solvents for cleaning.

IMPORTANT SAFEGUARDS (continued)



7. Do not allow anything to rest on the power cord. Do not locate this video product where the cord will be walked on.

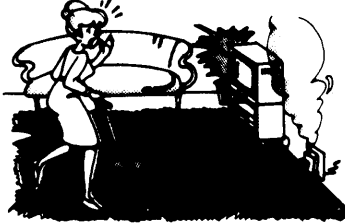

8. Do not overload wall outlets and extension cords because this can result in fire or electrical shock.

9. If an outside antenna or cable system is connected to the video product, be sure the antenna or cable system is grounded to provide some protection against voltage surges and built-up static charges. Section 810 of the National Electrical Code, ANS/NFPA 70, provides information with respect to proper grounding of the mast and supporting structure, ground of the lead-in wire to an antenna discharge unit, size of grounding of the mast and supporting structure, grounding of the lead-in wire to an antenna discharge unit, size of grounding conductors, location of antenna-discharge unit, connection to grounding electrodes, and requirements for the grounding electrode.
- a. Use No. 10 AWG (5.3 mm²) copper, No. 8 AWG (8.4 mm²) aluminum, No. 17 AWG (1.0 mm²) copper-clad steel or bronze wire, or larger, as a ground wire.
 - b. Secure antenna lead-in and ground wires to house with stand-off insulators spaced 4.6 feet (1.22-1.83 m) apart.
 - c. Mount antenna discharge unit as close as possible to where lead-in enters house.
 - d. Use jumper wire not smaller than No. 6 AWG (13.3 mm²) copper, or the equivalent, when a separate antenna-grounding electrode is used. See NEC section 810-21 (j).

EXAMPLE OF ANTENNA GROUNDING AS PER NATIONAL ELECTRICAL CODE

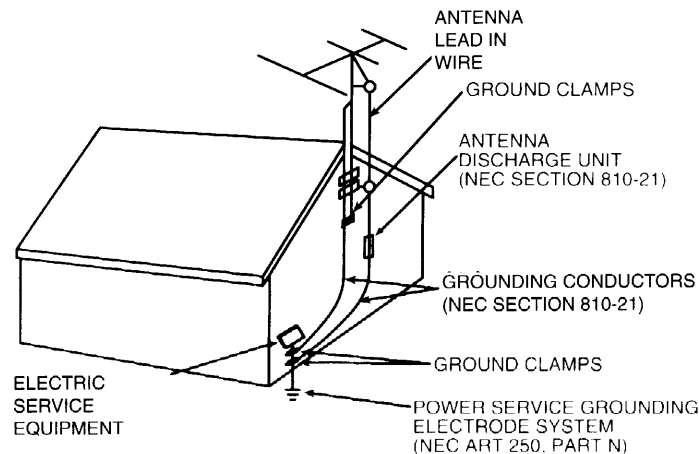

10. An outside antenna system should not be located in the vicinity of overhead power lines or other electric light or power circuit, or where it can fall on such power lines or circuits. When installing an outside antenna system, extreme care should be taken to keep from touching such power lines or circuits since contact with them might be fatal.

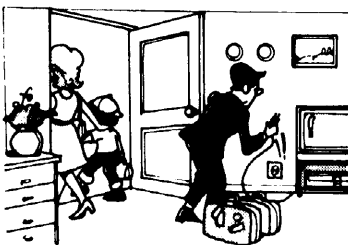

11. For added protection for this video product receiver during a lightning storm, or when it is left unattended and unused for long periods of time, unplug it from the wall outlet and disconnect the antenna or cable system. This will prevent damage to the video product due to lightning and power-line surges.

IMPORTANT SAFEGUARDS (continued)

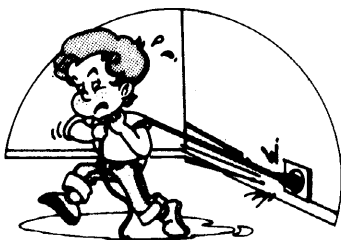

12. An appliance and cart combination should be moved with care. Quick stops, excessive force, and uneven surfaces may cause the appliance and cart combination to overturn.

13. Never push objects of any kind into this video product through openings since they may touch dangerous voltage points or short-out parts that could result in a fire or electrical shock. Never spill liquid of any kind on the video product.

14. Do not use attachments not recommended by the video product manufacturer since they may cause hazards.

15. Do not place this video product on an unstable cart, stand, tripod, bracket, or table. The video product may fall, causing serious injury or damage to the appliance. Use only with a cart, stand, tripod, bracket or table recommended by the manufacturer or sold with the video product.

16. Unplug this video product from the wall outlet and refer servicing to qualified service personnel under the following conditions :

A. When the power-supply cord or plug is damaged.

B. If liquid has been spilled or objects have fallen into the video product.

C. If the video product has been exposed to rain or water.

D. If the video product does not operate normally by following the operating instructions. Adjust only those controls that are covered by the operating instructions because an improper adjustment of other controls may result in damage and will often require extensive work by a qualified technician to restore the video product to its normal operation.

E. If the video product has been dropped or the cabinet has been damaged.

F. When the video product exhibits a distinct change in performance.

Do not attempt to service this video product yourself because opening or removing cover may expose you to dangerous voltage or other hazards. Refer all servicing to qualified service personnel.

17. Upon completion of any service or repairs, request the service technicians assurance that only Factory Authorized Replacement Parts that have the same characteristics as the original parts were used, and that routine safety checks have been performed to determine that the video product is in safe operating condition. Unauthorized parts may result in fire, electrical shock, or other hazards.

GENERAL INSTALLATION INFORMATION

Choosing a Location for your VCR

- Choose a location that is convenient, but away from sources of heat such as direct sunlight and heating units.
- If the VCR is to be installed in an equipment rack or cabinet with other components, be sure there is adequate ventilation at the back and around the sides of the components. The VCR should not be placed on or directly above a stereo amplifier because of the heat that rises from the amplifier.
- Choose a flat surface at least as large as the VCR so that it rests on its mounting feet. It is important that air can pass through the ventilation holes in the bottom of the unit to prevent it from overheating. Do not operate the VCR on a rug or carpet because the pile will obstruct these holes.

Some TV sets may cause interference in home VCRs. To avoid interference and get the best performance from your VCR, follow these guidelines :

- When placing the VCR under a TV, keep at least 18 inches between the bottom of the TV and the top of the VCR.
- If interference is present when the VCR is used on top of the TV or at the 18-inch distance below the TV set, move the VCR to a position beside the TV.
- If moving the VCR does not solve the interference problem, try plugging the VCR into a different wall socket.
- If interference continues after all of the above, call your dealer or service representative.

What Are VHF and UHF?

When television broadcasting began, twelve channels were called VHF (*very high frequency*) channels and numbered 2 through 13.

Later, as television broadcasting expanded channel 14 and higher we called UHF (*ultra high frequency*) channels.

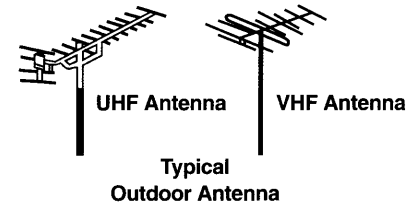
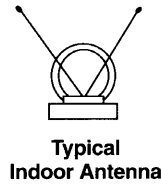

Your home antenna is a "signal receiver" that picks up TV broadcasts out of the air. There are several different types of antennas :

- Some receive only VHF channels.
- Some receive only UHF channels.
- Some receive both VHF and UHF channels.

Depending on the type of antenna, signals from the antenna can be conducted through either flat "twin-lead" cable or round "coaxial" cable as shown below.

Types of Antenna Cables

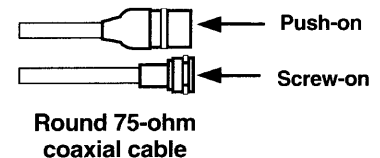
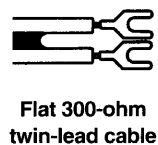

Cable-TV (CATV) supplies television signals directly by round cable without the need for a home antenna.

Cable-TV can deliver both VHF and UHF channels and programs not available from a home antenna. You will usually get better picture quality (for recording TV programs) if you connect an outdoor antenna or cable-TV system to your VCR. If this is not possible (or if you are in an area with good signal reception), use a good quality indoor antenna.

INSTALLATION

TV Antenna and VCR Connections

To connect the VCR to an antenna (Fig. 1) or to a combination VHF/UHF antenna (Fig.2), take the following steps:

Remove the VHF and/or UHF cable from your TV terminals and reconnect them to the VCR terminal as shown in the diagrams below.

Note: For VHF and UHF connections, follow procedure ① if you have a 75 Ω (ohm) coaxial cable, and follow procedure ② if you have a 300 Ω (ohm) twin lead connector.

Figure 1. VHF or UHF Reception Areas

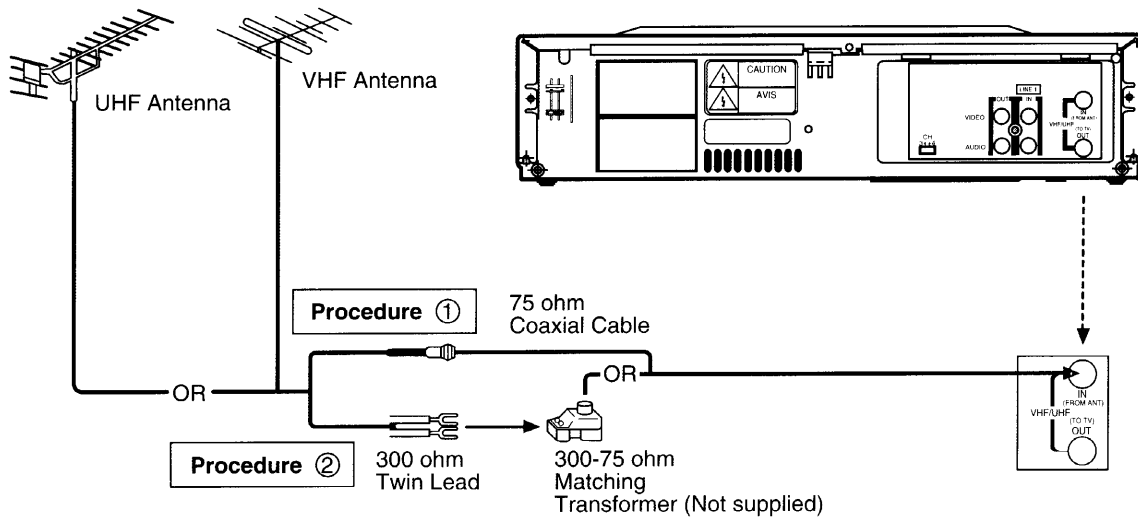
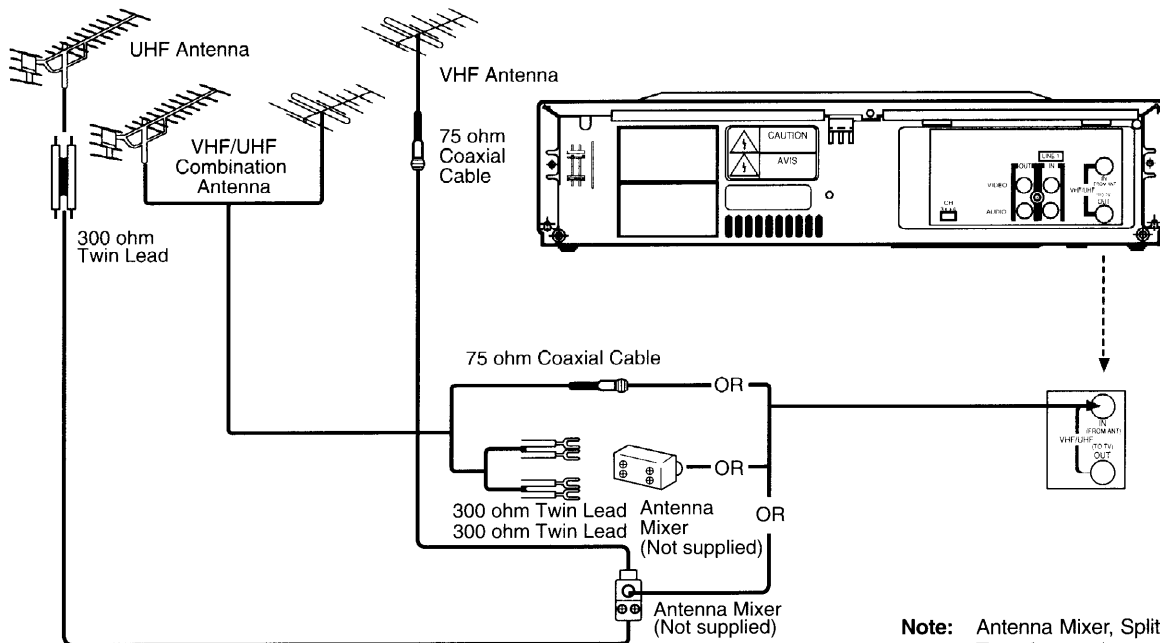

Figure 2. Combined VHF/UHF Reception Areas



Note: Antenna Mixer, Splitter and Matching Transformer (75 Ω \Rightarrow 300 Ω , 300 Ω \Rightarrow 75 Ω) are available from your local electronics store.

INSTALLATION(continued)

VCR and TV Connections

Connection to TV Antenna Terminals

Fig. 1 VHF (75 ohm/300 ohm) or VHF (75 ohm) terminal connection

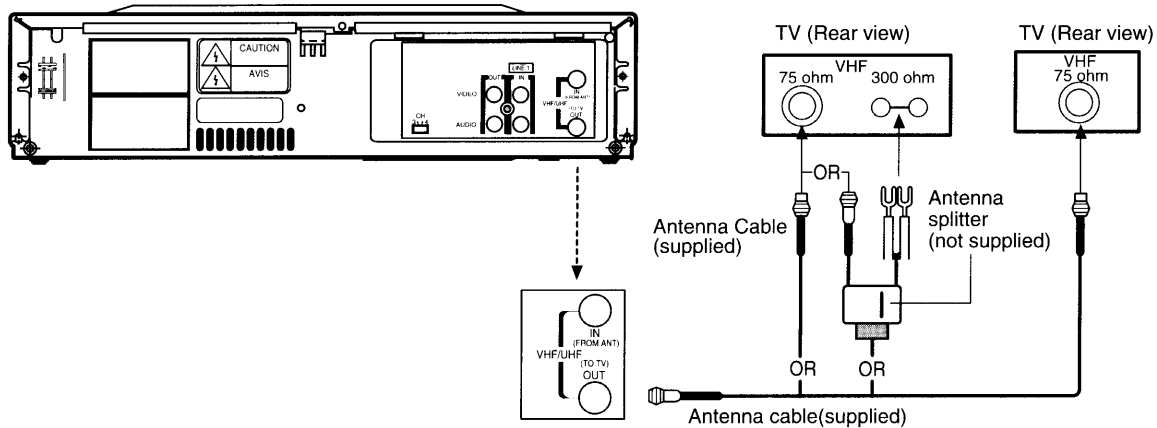
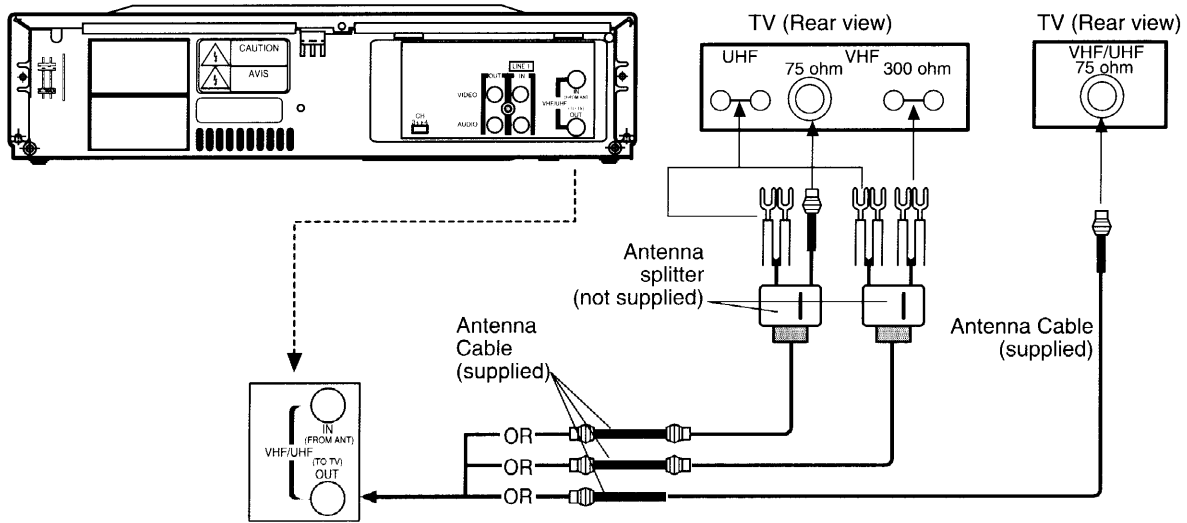
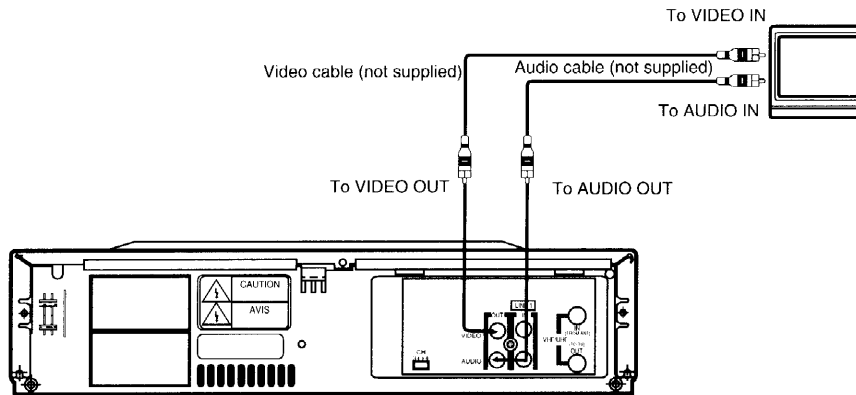

Fig. 2 VHF/UHF (75 ohm/300 ohm) or VHF/UHF (75 ohm) terminal connection



Connection to the TV with "VIDEO IN" and "AUDIO IN" connections



INSTALLATION (continued)

CATV Connections

There are several different cable television systems. There may be times when you use this VCR with one of these cable TV services.

We recommend that you consult your cable TV company to make sure that the cable is connected properly to match the cable TV system you want to watch.

Fig. 1 To record and watch unscrambled channels

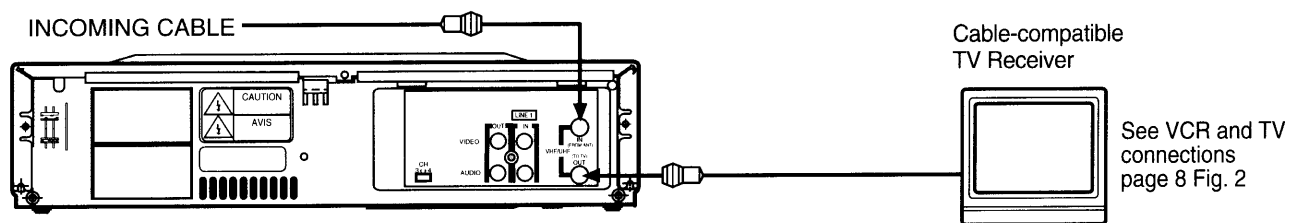

This set-up will enable you to do the following :

- Record unscrambled channels (limited by the capabilities of VCR tuner, for example 122 channel or 181 channel tuning).
- Record one channel and watch another.
- Use the programmable timer.

Fig. 2 To record and watch the same channel (unscrambled / scrambled)

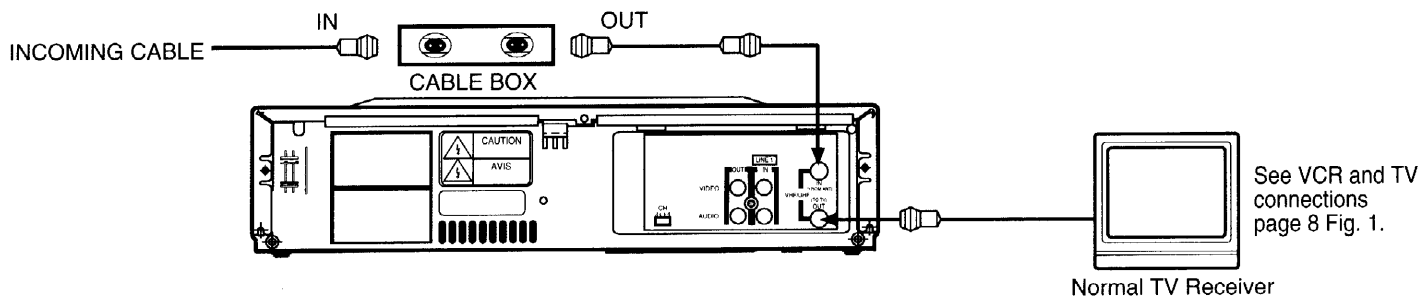

This set-up will enable you to do the following :

- Record all available cable channels through the cable box.
- Use the programmable timer or record only the channel selected at the cable box.

- Note:**
- Set VCR to the output channel of the cable box.
 - This set-up will not allow you to record one channel and watch another.

INSTALLATION (continued)

Fig. 3 To record and watch the same channel (unscrambled or scrambled) when the A/B switch is in the B position.

Fig. 4 To record one unscrambled or scrambled channel and watch another unscrambled channel when the A/B switch is in the A position.

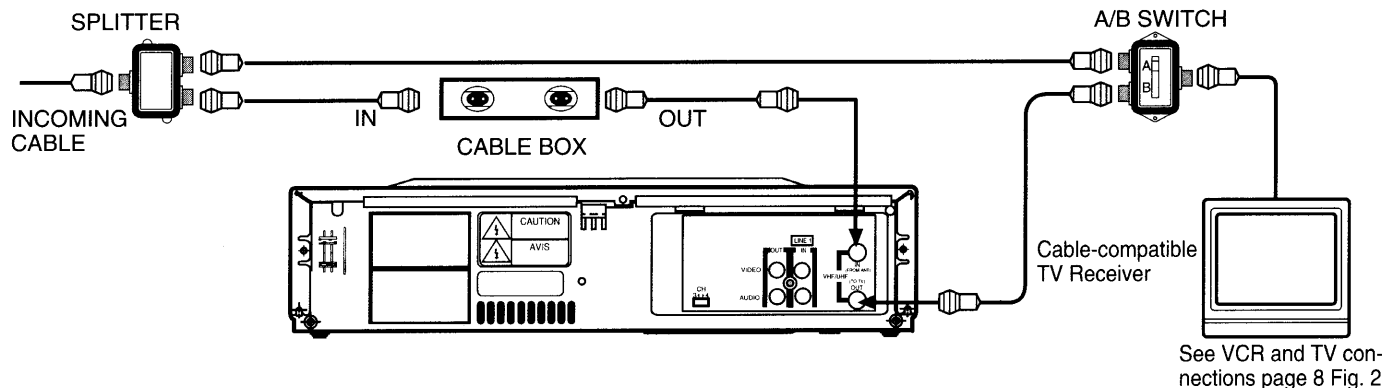

This set-up will enable you to do the following.

- Record all cable channels from the cable box.
- Record one scrambled channel and watch another unscrambled channel.
- Use the TV remote control when the A/B switch is in the "A" position.
- Use the programmable timer to record only the channel selected on the cable box. (cable box power must be ON).

Notes:

- Set the VCR channel selector to output channel of the cable box.
- Select the channel to be recorded on the cable box.
- Set the TV channel selector to output channel of VCR (3 or 4).

"Unscrambled" Cable Channels

Cable companies usually include "Unscrambled" channels in their basic subscription price. Depending on the tuning capability of your TV (how many cable channels your TV is capable of tuning to) you may not need a cable box (supplied by the cable company) to view "unscrambled" cable channels on your TV set.

"Scrambled" Channels

Extra (optional) pay cable channels, like HBO and Cinemax in some localities, are often "scrambled" by the cable company. To view these channels on your TV, you must use the cable (decoder) box supplied by the cable company.

Cable Box (supplied by Cable Company)

Until recently, all television and VCR receivers were equipped with 69 channel tuners capable of tuning the 12 standard VHF channels (2-13) and the 56 UHF channels (14-69). Since cable television systems do not use the UHF band, once they began expanding beyond 12 channel capacity (some cable companies transmit up to 100 channels)

some form of cable box became necessary to enable their subscribers to tune in the additional channels. This "cable box" rebroadcasts the programs to your TV set or VCR on one designated channel, usually channel 2, 3, or 4. When you use a cable box, you will normally change channels using the channel selector on the box. Some cable boxes have built-in decoders that translate "scrambled" pay TV channels (i.e. HBO) so they can be used by your TV set.

Frequency Conversion—simply means the ability to change one frequency to another (i.e. when channel 7 is selected—the cable box takes the channel 7 information and outputs the channel 7 information on channel 3 frequency). The cable box and the VCR use this principle of frequency conversion.

FIRST-TIME OPERATION

Even if you have never used a VCR before, you can get your VCR connected and working quickly by following the simplified steps below. The page numbers on which you can find detailed instructions for each of these steps are also listed for your convenience.

1. Unpack the VCR and Accessories

Make sure you remove all the accessories and information sheets that came packed with your VCR.

- Save the packing materials and box in case you ever need to ship or store your VCR.
- The items shown below came packed with your VCR. If any are missing or appear damaged, contact your TOSHIBA VCR dealer immediately.

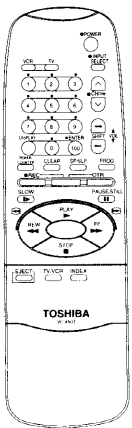

Remote Control

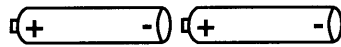

Remote Control Batteries
(Size "AAA" 1.5 Volts)

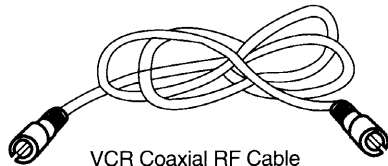

VCR Coaxial RF Cable

Caution: Avoid operating your VCR right after you have moved it from a cold location directly to a warm location. Moisture may have condensed on the head drum inside the VCR that may cause the tape to stick and damage the head wheel or tape. Let the VCR warm up for about 1-1/2 to 2 hours before inserting a video cassette.

2. Install the Batteries in the Remote Control

Turn the remote control over, and remove the cover of the battery compartment. Insert the batteries in the battery compartment so that their positive (+) ends contact the positive terminals. Replace the cover.

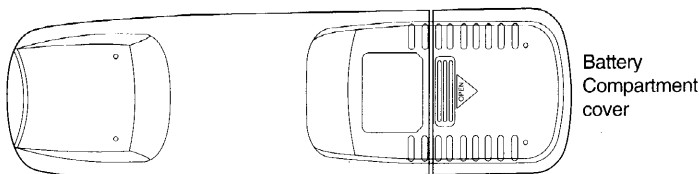

Battery
Compartment
cover

Note: Never place anything heavy on top of the remote control or lay it upside-down. This may accidentally depress the buttons for a long time and discharge the batteries.

Replace the batteries when the VCR fails to respond to the remote control.

Remove the batteries from the remote control if it will not be used for a month or more. This will help prevent possible damage from battery leakage.

3. Connect an Antenna or Cable-TV System to VCR

Your VCR is quite easy to install. To connect an antenna or cable-TV system, you will first be attaching the antenna to the VCR, and then connecting the VCR to the TV as shown below. *Detailed instructions for connecting more complicated types of systems are on page 7-10.*

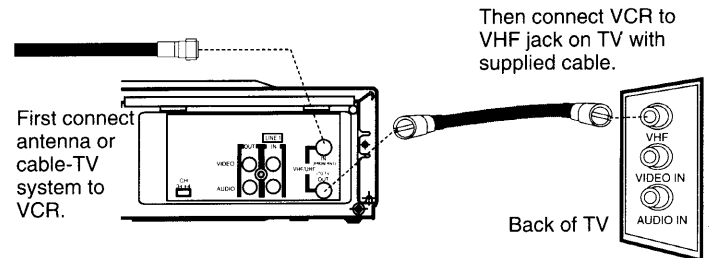

Remember: When you connect the *OUT TO TV* jack on the VCR to the TV as shown above, you will be tuning your TV to channel 3 or 4 to see the signals from the VCR.

Optional for TV Monitors: If your TV is a monitor that has *AUDIO* and *VIDEO IN* jacks, you can use optional audio/video cables to connect your VCR to the TV as shown below. This connection may produce a slightly better picture during playback.

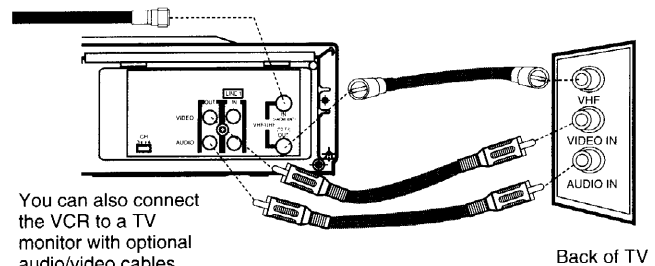

Remember: When you connect the *AUDIO* and *VIDEO OUT* jacks on the VCR to a TV monitor as shown above, you will be tuning your monitor to its video input channel (varies with TV models) to see the signal coming from the VCR. You will also be able to see the VCR's signal on channel 3 or 4.

4. Set the CH3/CH4 Switch on the Back of the VCR to Select the "VCR Channel"

First set the *CH3/CH4* switch on the back of the VCR to either channel 3 or 4, and then tune your TV to the same channel. This is called the "VCR Channel".

Remember that your TV must always be turned on and tuned to this channel (3 or 4) for you to see what the VCR is doing (unless you have a TV monitor). If you have connected your VCR to a TV monitor with audio/video cables as shown above, set your TV to its proper video input channel (such as L1, etc.) to see what the VCR is doing.

FIRST-TIME OPERATION (continued)

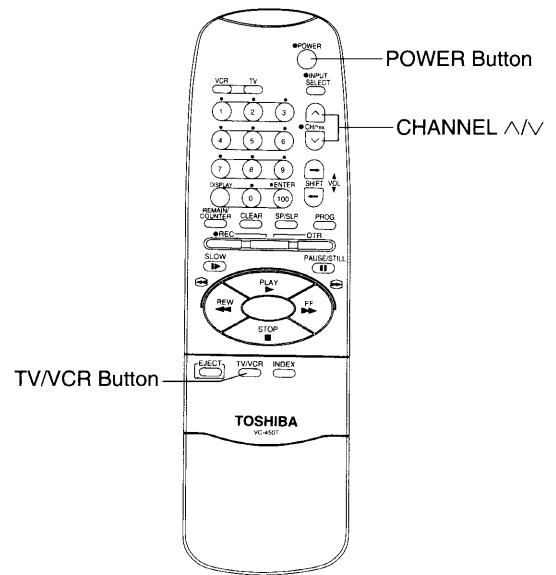
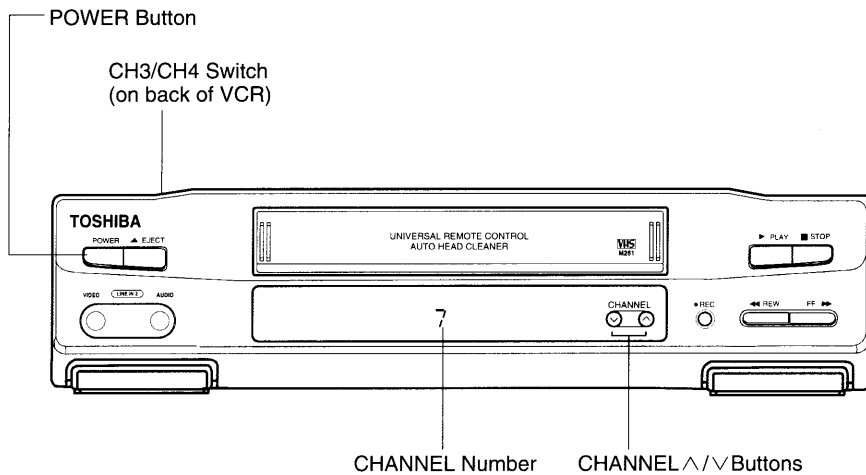

5. Turn on the VCR and Select an Active Channel

- Plug in the VCR's power cord and press the *POWER* button on the VCR (or the *POWER* button on the remote control) to turn it on.
- Press the *CHANNEL* button up or down to select an active channel in your area. The channel number will appear in the VCR's display panel.

6. Set the CATV

- See page 13 for "Auto Channel Program Channels into Memory".

7. Learn How to Use the TV/VCR Button

Pressing the *TV/VCR* button turns the VCR indicator in the display panel on or off. The VCR indicator turns on automatically each time you press the *PLAY* button or insert a cassette tape with the safety tab removed.

- When the VCR indicator is on, your TV must be tuned to the "VCR Channel" (3 or 4) so that you can see what the VCR is doing (unless you have a TV monitor as explained below). The TV then receives the picture from the VCR, and you can select channels with the *CHANNEL* buttons on the VCR (or its remote control).
- When the VCR is turned off (or the VCR indicator is off), your TV receives the picture from your home antenna or cable-TV system as it did before you connected the VCR. You can then use the *CHANNEL* buttons on your TV to select channels.
- The *TV/VCR* button lets you record one channel with the VCR while you watch another channel on the TV. *Details are on page 29.*

Note for TV Monitor: Whenever the VCR is turned on, you will be able to see what it is doing on the video input channel if you have connected a TV monitor using the *AUDIO* and *VIDEO* jacks. The signal from the VCR on the video input channel will not be affected by turning off the VCR indicator. However, be sure to turn off the VCR indicator when you are recording one channel on the VCR and want to watch a different channel on the TV.

8. Test the VCR Connections

1. Turn on the TV and tune it to the "VCR Channel" (3,4, or video input).
2. Turn on the VCR and select an active channel using the *CHANNEL* buttons on the VCR (or VCR's remote control).
3. If your "VCR Channel" is 3 or 4, make sure the VCR indicator is on in the VCR's display panel. Press the *TV/VCR* button to turn it on.

Note: If you have connected your VCR to a TV monitor using the *AUDIO* and *VIDEO* jacks, tune your TV to the video input channel. The VCR indicator does not have to be on for this connection.

Test 1: Make sure the TV's picture and sound are from the channel you have selected on the VCR and of the same quality they were before you connected the VCR. Change channels on the VCR with the *CHANNEL* buttons on the VCR (or the VCR's remote control). If the picture on the TV does not change to the channel you select with the VCR, go back and carefully check the connections and previous steps.

Test 2: Turn off the VCR, and change channels on the TV with the TV's *CHANNEL* buttons. Make sure the picture and sound you see on the TV and from the channel you selected on the TV are of the same quality they were before you connected the VCR. If the TV does not operate as it did before you connected the VCR, go back and carefully check the connections.

FIRST-TIME OPERATION (continued)

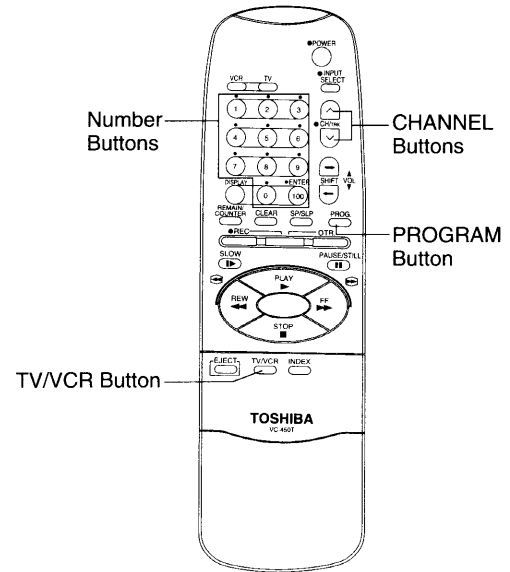
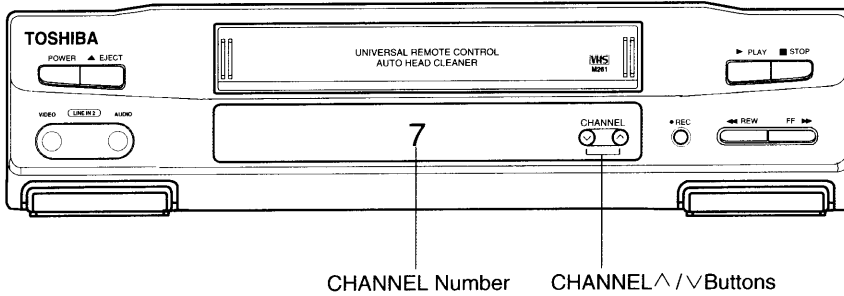

9. Auto Channel Program Channels into Memory

The channel memory is the list of channels your VCR will stop on when you press its *CHANNEL* button up or down. The quickest way to program the VCR's channel memory with channels in your area is to use the autoprogram feature. The VCR will automatically cycle through all channels and place all active channels into its channel memory for you. You can then add or erase individual channels as desired.

Here is how to start the autochannel programming feature :

1. Make sure the VCR and TV are turned on and the TV is tuned to its "VCR Channel" (3,4 or video input). If you are watching the VCR on channel 3 or 4 of your TV, make sure the VCR indicator is on the VCR's display panel.
2. Press the *PROG* button on the remote control and then press the number "4" button to display the following menus.

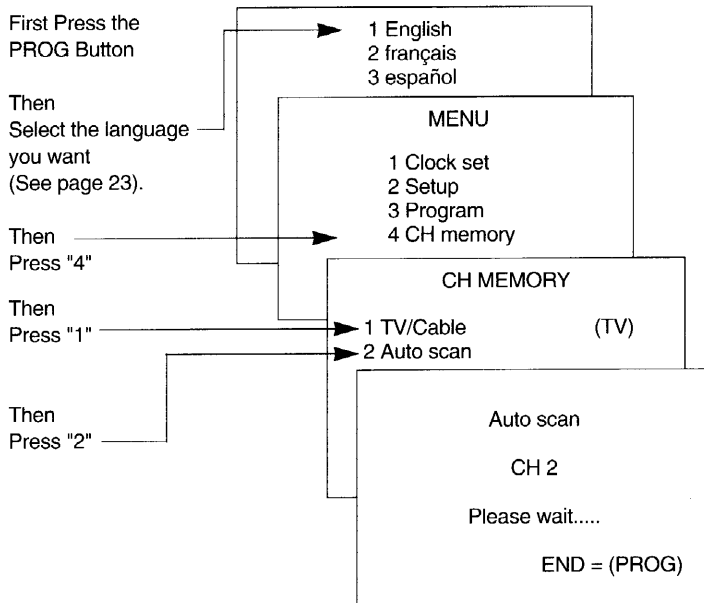

3. Before you start Auto Channel Programming, you must tell your VCR whether you have an antenna or a cable-TV system connected to it. Press the number "1" button to change the setting of the TV/Cable display.

- If you connected a home-antenna system to your VCR, set this display to TV.
- If you connected a cable-TV system to your VCR, set this display to Cable-TV.

4. After you have selected TV or Cable-TV, press the number "2" button while the menu appears on the TV to start the VCR's autoprogramming.

Note: The VCR will automatically cycle through all the channel numbers and place only the active channels into its channel memory. This takes about one or two minutes. The channel numbers will stop changing on the display when the autochannel programming is completed.

Auto Channel Programming is usually a one time procedure. If you move to a new location that has different channels or if power is interrupted for an extended period (about one minute), the channel memory will have to be reprogrammed.

5. After the VCR has finished Auto Channel Programming, you can press the *CHANNEL* button up or down to see what channels are in channel memory.

Notes: Occasionally an active channel may be missed if the signal is weak or the channel happens to be "off the air" when the VCR is autoprogrammed.

An inactive channel may be included in channel memory if there is some "noise" or stray signal on the channel during Auto Channel Programming.

FIRST-TIME OPERATION (continued)

9. Auto Channel Program (continued)

To add or erase channels from channel memory:

1. Press the *PROG* button on the remote control, then press number button "4", then press number button "3". The following menus will appear on the TV screen.

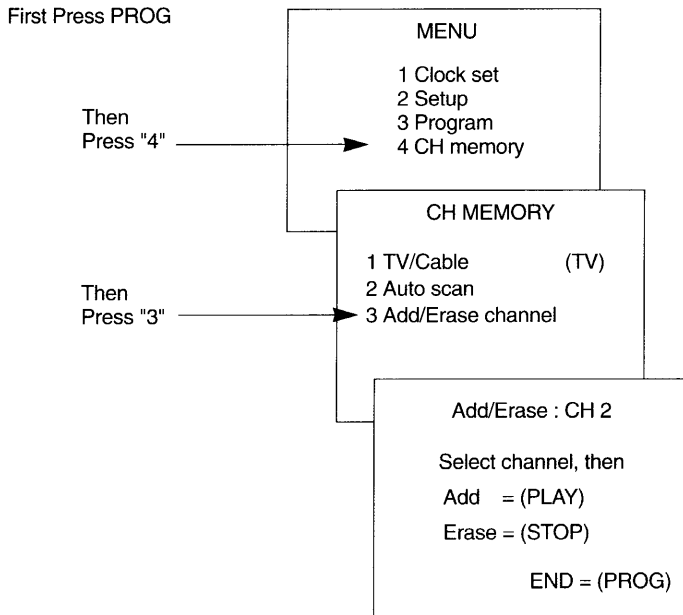

First Press
PROG

Then
Press "1"

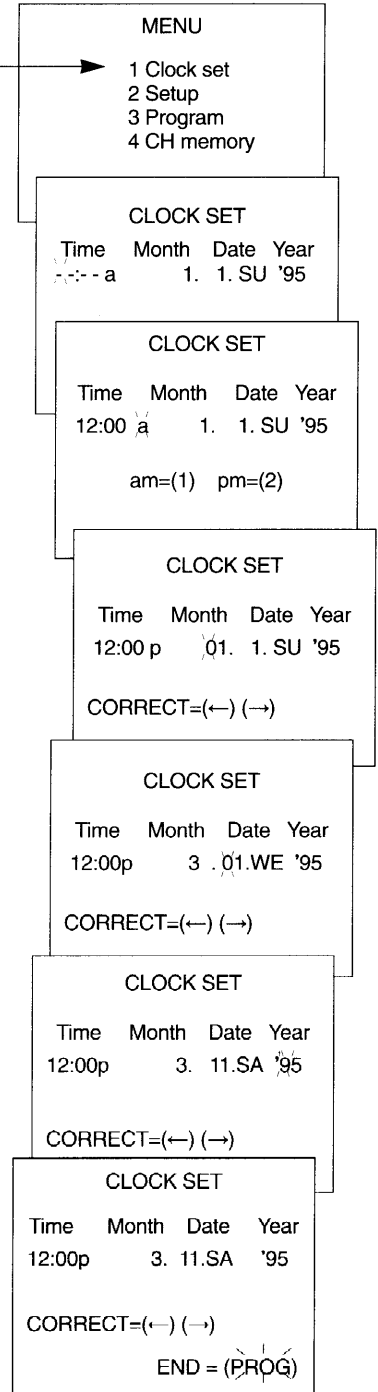

- To add a channel (up to 99) to channel memory, first select the channel you want to add by pressing two number buttons on the remote control. Remember to always press "0" before a single-digit channel number. (For example, press "0" then "8" for channel 8.) Then press the *PLAY* button on the remote control. To add Cable-TV channels over 99, press the "100" button and then two number buttons.
- To erase a channel, first press the *CHANNEL* up or down button (or number buttons) to select the channel you want to erase. Then press the *STOP* button on the remote control.

2. When finished, press the *PROG* button on the remote control.

10. Set the Clock

The clock display area in the VCR's display panel will look like " -:- - " until you set the clock. The clock must be set to the correct time before you can program the VCR for timer recordings. Once the correct time and date are set, the VCR will automatically maintain them unless power is interrupted.

To set the clock, press the *PROG* button on the remote control, then press number button "1". The following menus will appear on the TV screen.

When the *CLOCK SET* menu appears, use the number buttons on the remote control to enter the correct time (including *AM* and *PM*) and date as indicated by the flashing portion of the menu on the TV screen.

Notes: Always press "0" before single-digit hours, minutes, months, or days. For example, to enter a time of 5:07, press "0", "5" "0", then "7". To enter August 2, 1995, press "0", "8", "0", "2" "9", then "5".

When setting clock of February 29 of leap year (1996, 2000, 2004 ...), set first the year and then, set day.

FIRST-TIME OPERATION (continued)

11. Make a Recording and Play It Back

Follow the steps below to practice making a short recording and then play it back.

Details on recording speeds, features, and recording guides are on pages 28-36.

Details on playback features and playback guides are on pages 25-27.

Several buttons on the remote control perform the same function as buttons with the same name on the VCR. You may use whichever button is more convenient at the time.

Details on the operating controls of the VCR and remote control are on pages 17 and 19-20

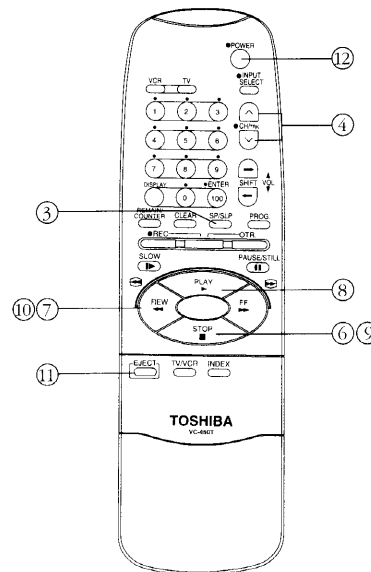
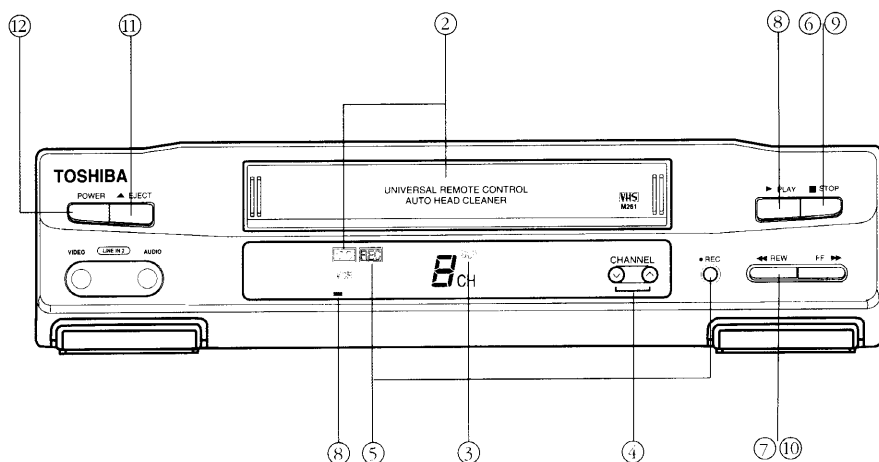

To make a recording :

- ① Turn on the TV and tune it to your "VCR Channel" (3*, 4*, or video input).
* The TV must be tuned to the same channel you selected with the CH3/CH4 switch on the back of the VCR.
- ② Insert a cassette with the record-protect (safety) tab intact. The cassette-in indicator  will light in the VCR's display panel. *Details about inserting and removing cassettes are on page 24.*
Notes: The VCR is automatically turned on when you insert a cassette.

If you insert a cassette with its record-protect (safety) tab removed, the VCR will automatically begin playback.

If a cassette without a record-protect (safety) tab is inserted, the VCR ejects it when you press the REC button. *Details about the record-protect (safety) tab are on page 24.*

Make sure the VCR indicator appears in the VCR's display panel. If not, press the TV/VCR button to turn it on.
- ③ Select a tape recording speed by pressing the SP/SLP button. The tape speed indicator (SP or SLP) appears in the VCR's display panel. Use SP for normal recording. Tape recording speeds are compared on page 24.
Note: The VCR automatically selects the correct tape speed for playback.
- ④ Select the channel to be recorded by pressing the CHANNEL \wedge or \vee button. The channel number appears in the VCR's display panel and on the TV screen.

- ⑤ Start recording by pressing the REC button. The record indicator  will light in the VCR's display panel.
- ⑥ When you are finished recording, press the STOP button on the VCR (or the STOP button on the remote control).

To play the recording back:

- ⑦ Rewind the tape by pressing the REW button on the VCR (or the REW button on the remote control). If you do not want to play back the tape, skip to step ⑪.
- ⑧ Press the PLAY button to begin playback. The bar indicator () will advance to the right in the VCR's display panel.
- ⑨ When you are finished playing back the tape, press the STOP button on the VCR (or the STOP button on the remote control).
- ⑩ Rewind the tape by pressing the REW button on the VCR (or the REW button on the remote control).
- ⑪ To eject the cassette, press the EJECT button on the VCR (or the EJECT button on the remote control).
- ⑫ Turn off the VCR by pressing the POWER button on the VCR (or the POWER button on the remote control).
- ⑬ Turn off the TV.

VCR OPERATING CONTROLS

VCR Jack Panels

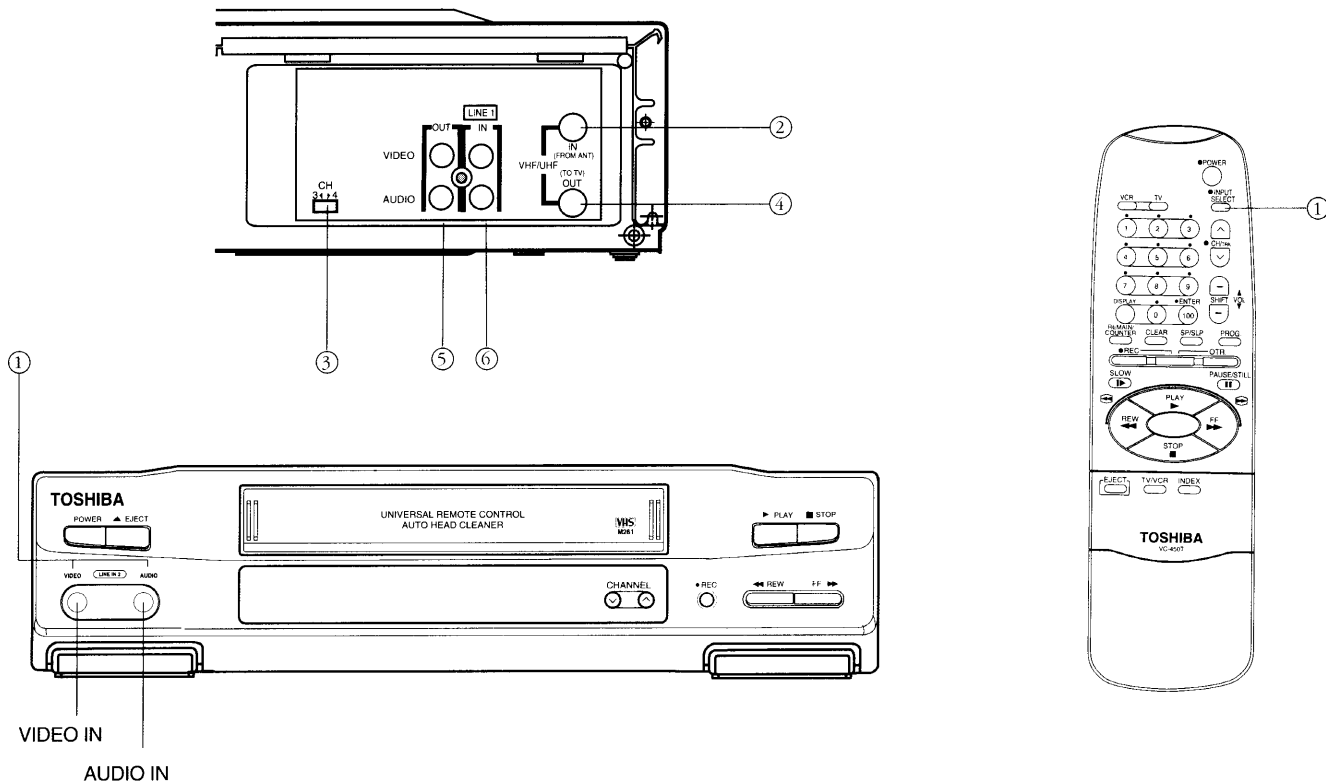

① AUDIO IN and VIDEO IN Jacks on the VCR's front panel

- These jacks are used to receive signals from another device (such as a camcorder or another VCR).
- To see the signal from these jacks, press the *INPUT SELECT* button to light the "L2" in the VCR's display panel.
- At the same time you can find the "LINE2" on the TV screen using the *INPUT SELECT* button on the remote control.
- See page 35 for "Recording From a Camcorder".
- See page 36 for "Recording From Another VCR".

② IN FROM ANT (Antenna) Connector

- Attach a home antenna or cable-TV system to this connector.
- See pages 7-10 for home antenna connections.
 - See pages 9-10 for cable-TV connections.

③ CH3/CH4 Switch

- Whatever channel you select with the CH3 or CH4 switch is the same channel to which you must tune your TV to see what the VCR is doing.
- See page 11 for details.

④ OUT TO TV Connector

- Connect the supplied VCR coaxial RF cable to this connector. Then connect the cable to your TV.
- See page 7-10 for home antenna connections.
 - See page 9-10 for cable-TV connections.

⑤ AUDIO OUT and VIDEO OUT Jacks

- These jacks are used to send signals from the VCR to another device.
- See page 36 for "Recording From Another VCR".
- See page 40 for "Copying VCR Recording."

⑥ AUDIO IN and VIDEO IN Jacks on the VCR's rear panel

- These jacks have the same function as explained in ①.
- Note:** To see the signal from these jacks, press the *INPUT SELECT* button to light the "L1" in the VCR's display panel.

VCR OPERATING CONTROLS (continued)

VCR Operating Controls

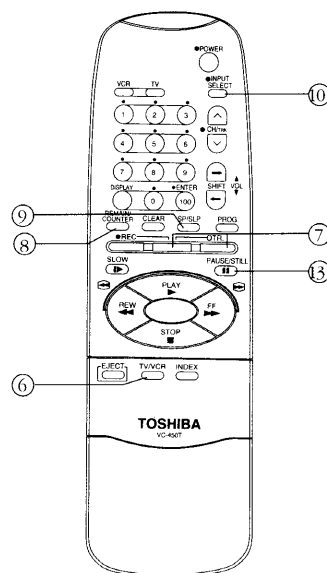
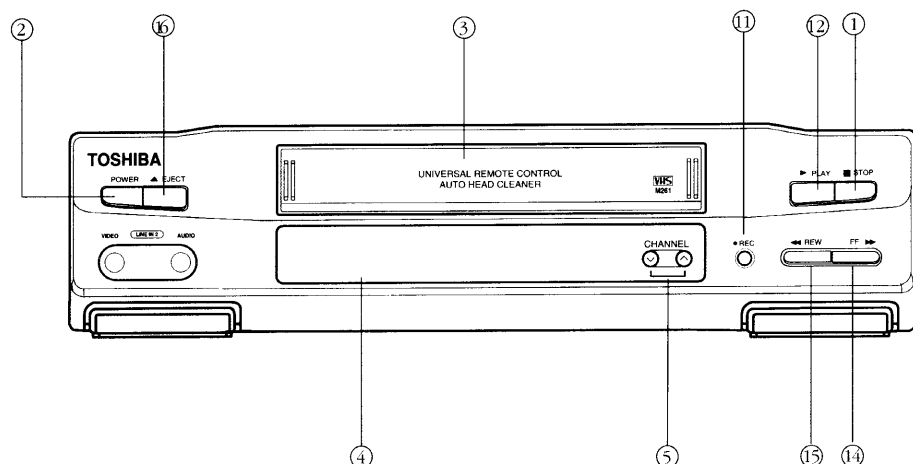

① STOP Button

- Press this button to stop the normal functions of recording, playback, rewinding, fast-forwarding, recording, pause or still.

② POWER Button

- Press the *POWER* button to turn the VCR on or off.
- The VCR will stop and turn off if you press the *POWER* button during normal recording, playback, rewind or fast-forward operation.
- If you want to stop a normal timer recording or one touch recording (OTR), press the *POWER* button.

③ Cassette Door (See page 24.)

④ Infrared Remote Sensor

This sensor receives signals from the remote control. Aim the remote control at this sensor. There can not be any obstructions between them.

⑤ CHANNEL \wedge/\vee Buttons

- After channels have been autoprogrammed into the channel memory scan list, press these buttons to select the next higher or lower channel.
- Press *CHANNEL \wedge* to select a higher channel.
 - Press *CHANNEL \vee* to select a lower channel.

⑥ TV/VCR Button

Press the *TV/VCR* button to turn the VCR indicator in the VCR's display panel on or off (See page 12).

⑦ OTR (One Touch Recording) Buttons (See page 30).

⑧ REMAIN/COUNTER Button

Press this button to switch between the linear time counter and the remaining amount of tape in a display mode. (See page 39.)

⑨ SP/SLP Button (See page 28).

⑩ INPUT SELECT Button

- Press one time to turn on the L1 indicator in the VCR display panel to record from *AUDIO* and *VIDEO IN* jacks on the VCR's rear panel.
- Press twice to turn on the L2 indicator in the VCR display panel to record from *AUDIO* and *VIDEO IN* jacks on the VCR's front panel. (L1=LINE INPUT 1, L2=LINE INPUT 2)

⑪ REC Buttons

Press to begin recording. (See pages 28, 29, 35, 36).

⑫ PLAY Button

Press to begin playback. (See pages 25-27.)

⑬ PAUSE/STILL Button

- Still frame (See page 26).
- Recording pause (See page 28, 35, 36.)

⑭ FF (Fast-Forward) Button

- Press to fast-forward the tape when the VCR is in the stop mode or the forward search mode.
- Press to operate the forward search in the play mode or the fast-forward mode.
- Keep pressing to operate the forward ACCEL search in the play mode or the forward search mode. (See page 26.)

⑮ REW Button

- Press to rewind the tape when the VCR is in the stop mode or the reverse search mode.
- Press to operate the reverse search in the play mode or the rewind mode.
- Keep pressing to operate the reverse ACCEL search in the play mode or the reverse search mode. (See page 26.)

⑯ EJECT Button

- Press this button to eject the cassette when the VCR is stopped. (See page 24.)

VCR OPERATING CONTROLS (continued)

VCR Display Panel

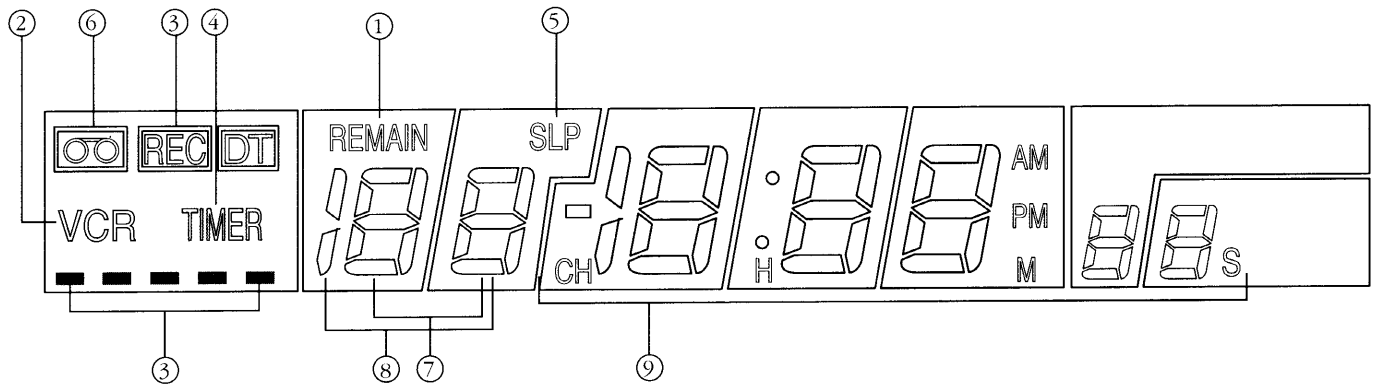

① REMAIN indicator

This indicator lights when the display function to indicate the remaining time on the tape is operating.

② VCR Indicator

(See page 12 for "Learn How to Use the TV/VCR Button".)

③ Status Indicators

This area of the display shows what the VCR is doing.

- [REC] and advancing bar (■) for record, advancing bar (■) for playback, high speed advancing bar (■) for fast forward or forward search to the right, high speed advancing bar (■) for rewind or reverse search to the left.
- This area is blank when the VCR is in the stop mode.

④ TIMER Indicator

(See pages 30-34.)

⑤ Tape Speed Indicators (SP/LP/SLP)

(See page 24.)

⑥ Cassette-in Indicator

The cassette-in indicator lights when a cassette is properly inserted into the VCR. (See page 24.)

⑦ LINE Indicator

Press the *INPUT SELECT* button to turn the "L1(L2)" indicator on or off in the display panel.

- Turn the "L1(L2)" indicator off for normal recording from the VCR's built-in tuner.
- Turn the "L1(L2)" indicator on to record from another component (such as a camcorder or another VCR) connected to the *AUDIO* and *VIDEO IN* jacks on the VCR.

⑧ Channel Number Display

The channel number selected is displayed in this area.

⑨ Time and Time Counter Display

Press the *DISPLAY* button on the remote control to switch between the current time, the linear time counter and remaining time.

- See page 14 for "Set the Clock."
- See page 27 for "Time Counter with Memory-Stop Feature".
- See page 39 for "Remaining Tape Display Function".

Notes:

- Those indicators marked multifunctional are sections of the multidisplay which serve a number of purposes. In other words, a number of different symbols appear in the same place according to the buttons you press. This will become clear as you actually begin using this VCR.

VCR OPERATING CONTROLS (continued)

Remote Control Buttons that Control the VCR

When using the remote control, always aim it directly at the front of the component you are trying to control. This remote control can control the TOSHIBA VCR and a compatible TV.

To operate the remote control, first press one of the component buttons (TV or VCR) to tell the remote control which component you want to control. The other buttons on the remote control will then

control that component. To control a different component, first press the corresponding (TV or VCR) button.

Only the buttons that control the VCR are explained here. Buttons that control a compatible TV are explained on pages 21-22.

VCR Button: If you press the VCR button, the remote control will go into the "VCR mode" and control the VCR.

The remote must be in the "VCR mode" before the other buttons will control the VCR.

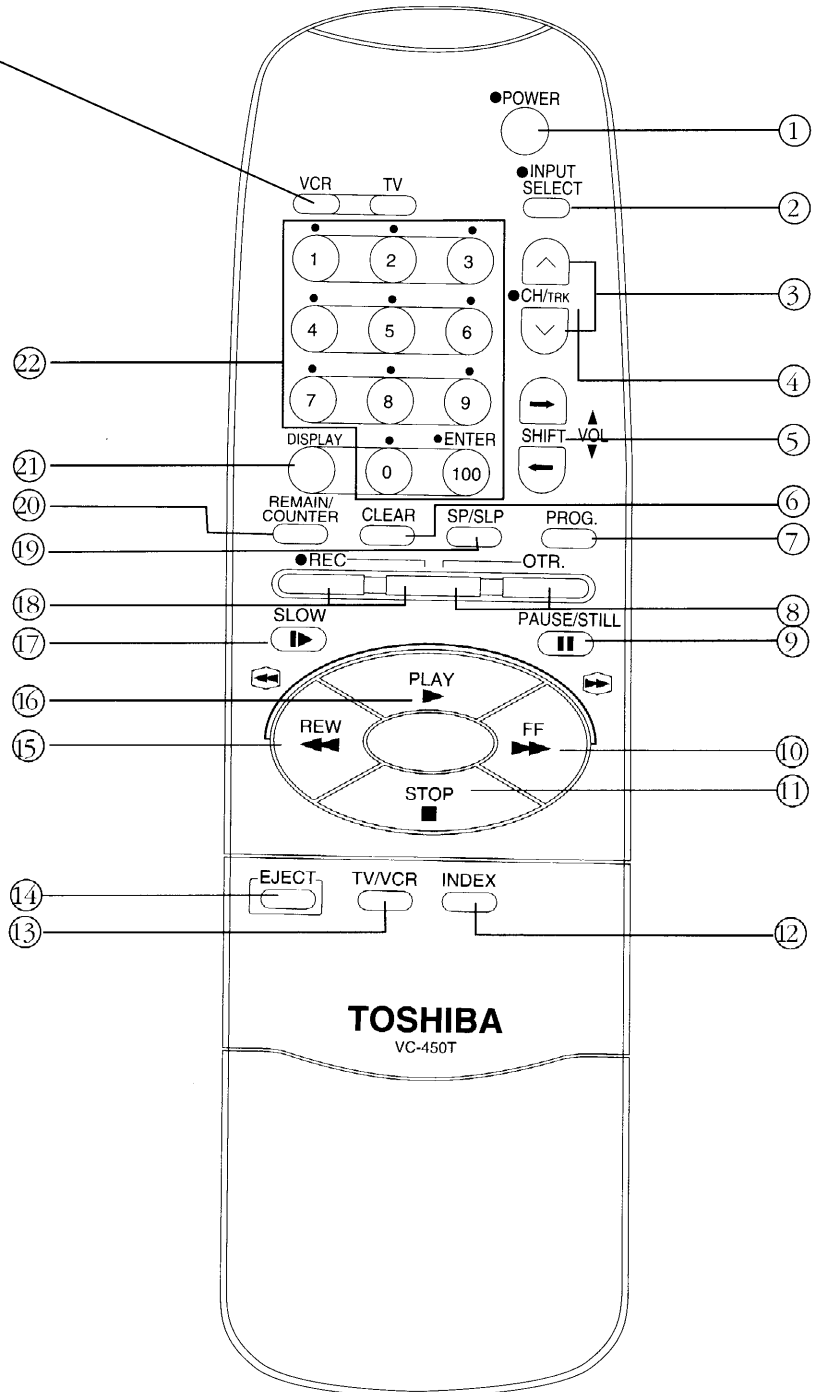

VCR OPERATING CONTROLS (continued)

Remote Control Buttons that Control the VCR (continued)

- ① **POWER Button**
Press the *POWER* button to turn the VCR on or off.
- ② **INPUT SELECT Button**
Press to turn the "L1(L2)" indicator on or off in the VCR's display panel. (See pages 17 and 18.)
- ③ **CHANNEL \wedge / \vee Buttons**
Press the *CHANNEL \wedge* button to select the next higher channel or press the *CHANNEL \vee* button to select the next lower channel in the VCR's channel memory. (See pages 13, 14, 17.)
- ④ **TRACKING \vee / \wedge Buttons**
(See pages 26.)
- ⑤ **SHIFT \leftarrow \rightarrow buttons**
Press to re-enter the number or shift the cursor in the menus.
- ⑥ **CLEAR Button** (See pages 27.)
Press the *CLEAR* Button to return the counter to 0:00:00 on the screen.
- ⑦ **PROG Button**
Press the *PROG* button to display the program menu on the TV screen for setting the clock, programming the timer, channel set and setting up the VCR.
- ⑧ **OTR (One Touch Recording) Button**
Press these *OTR* and dummy buttons simultaneously to start OTR. (See page 30.)
- ⑨ **PAUSE/STILL Button**
 - Playback pause (See page 26.)
 - Recording pause (See page 28, 35, 36.)
- ⑩ **FF (Fast-Forward) Button**
 - Press to fast-forward the tape when the VCR is in the stop mode or the forward search mode.
 - Press to operate the forward search in the play mode or the fast-forward mode.
 - Keep pressing to operate the forward ACCEL search in the play mode or the forward search mode. (See page 26.)
- ⑪ **STOP Button**
Press this button to stop the normal functions of record, play-back, rewind, fast-forward, record-pause, or still frame.
- ⑫ **INDEX Button** (See pages 37-38.)
- ⑬ **TV/VCR Button** (See page 12.)
- ⑭ **EJECT Button**
Press to eject the tape in the VCR.
- ⑮ **REW Button**
 - Press to rewind the tape when the VCR is in the stop mode or the reverse search mode.
 - Press to operate the reverse search in the play mode or the rewind mode.
 - Keep pressing to operate the reverse ACCEL search in the play mode or the reverse search mode. (See page 26.)
- ⑯ **PLAY Button**
Press to begin playback. (See page 25-27.)
- ⑰ **SLOW Buttons** (See page 26.)
- ⑱ **REC Button**
Press these *REC* and Dummy buttons together to start recording. (See pages 28, 29, 35, 36.)
- ⑲ **SP/SLP Button** (See page 28.)
- ⑳ **REMAIN/COUNTER Button**
Press to switch between the linear time counter and the remaining amount of tape in a display mode. (See page 39.)
- ㉑ **DISPLAY Button** (See page 27.)
- ㉒ **Number Buttons ("0" through "9" and "100")**
 - To select any channel up to 99, press two number buttons (ex : To select CH 9, press 0, 9 buttons).
 - To select a cable-TV channel over 99, press the "100" button and then two number buttons (ex : To select CH 103, press 100, 0, 3 buttons).
 - The number buttons are also used with the VCR's special features.
 - If the second digit is not pressed within two seconds, channel "100" will be selected. if the third digit is not pressed within two seconds, channel 102 will be selected.

VCR OPERATING CONTROLS (continued)

Remote Control Buttons that Control a TV

The digital remote control that came packed with your VCR controls your VCR and some functions of a compatible TOSHIBA TV. The remote can also be programmed to control some functions of up to 30 different compatible TV brands (including GE, SONY, MAGNAVOX, SEARS, HITACHI, PANASONIC, MITSUBISHI, RCA and others). However, it will not operate all TVs made by these manufacturers. If your TV does not respond to any of the button combinations, the TV probably cannot be controlled by this remote control.

To find out if your TV is compatible, follow the instructions below. If the TV responds to one of the button combinations shown in the chart below, it is compatible.

Programming the VCR Remote to Control a Compatible TV (Other Than TOSHIBA)

Because the remote control is designed to operate 14 different types of TVs (up to 30 different brands), you must first program the remote control to match the remote system of your TV. Follow these four easy steps :

1. Turn on your TV.
2. Point the VCR's remote control toward the front of your TV.

3. Hold down the *TV* button while pressing one of the other buttons shown in the chart below. The TV will change channels when the correct matching button combination is pressed. Try each of the combinations until you find the right one.

4. Release both buttons when the TV start changing channels. Your remote control is now programmed to control your TV.

You may have to re-program the remote control to control a compatible TV (other than TOSHIBA) when you replace the remote control's batteries.

After the VCR's remote control is programmed, it will control certain functions of your TV depending on the type of TV. Keep these exceptions in mind :

- On a TV that has a 12-position knob-type channel selector, you will only be able to select the first ten positions (1 through 10).
- To turn on a compatible TOSHIBA TV, press the *POWER* button. To turn on a different type of compatible TV (after the remote has been programmed), press the *TV* button, then press the *POWER* button.
- Not all functions may be available on your TV. For example, previous channel may not work even though the *CHANNEL* \wedge/\vee buttons do work.

Step(continued)	Hold TV button and press these additional buttons to program remote:						
	<i>TV and 1 (TOSHIBA)</i>	<i>TV and 2</i>	<i>TV and 3</i>	<i>TV and 4</i>	<i>TV and 5</i>	<i>TV and 6</i>	<i>TV and 7</i>

After programming your VCR remote, it will control the TV functions listed below:

Remote Button	TV functions which can be controlled:						
<i>TV</i>	—	—	—	—	—	—	POWER ON (RCA)
<i>POWER</i>	ON/OFF	ON/OFF	ON/OFF	ON/OFF	ON/OFF	ON/OFF	ON/OFF
<i>0 THROUGH 9</i>	0-9	0-9	0-9	0-9	0-9	0-9	0-9
<i>100</i>	100	—	ENTER	100	100	—	100
<i>CHANNEL \wedge/\vee</i>	CH \wedge/\vee	CH \wedge/\vee	CH \wedge/\vee	CH \wedge/\vee	CH \wedge/\vee	CH \wedge/\vee	CH \wedge/\vee
<i>VOL \wedge/\vee</i>	VOL \wedge/\vee	VOL \wedge/\vee	VOL \wedge/\vee	VOL \wedge/\vee	VOL \wedge/\vee	VOL \wedge/\vee	VOL \wedge/\vee
<i>INPUT SELECT</i>	TV/VIDEO	—	TV/VIDEO	—	—	—	TV/VIDEO

Step(continued)	Hold TV button and press these additional buttons to program remote:						
	<i>TV and 8</i>	<i>TV and 9</i>	<i>TV and 0</i>	<i>TV and CHANNEL \wedge</i>	<i>TV and CHANNEL \vee</i>	<i>TV and 100</i>	<i>TV and INPUT SELECT</i>

After programming your VCR remote, it will control the TV function listed below:

Remote Button	TV functions which can be controlled:						
<i>TV</i>	—	—	—	—	—	—	—
<i>POWER</i>	ON/OFF	ON/OFF	ON/OFF	ON/OFF	ON/OFF	ON/OFF	ON/OFF
<i>0 through 9</i>	K, A-I	0-9	0-9	0-9	0-9	0-9	0-9
<i>100</i>	—	100	100	—	—	ENTER	—
<i>CHANNEL \wedge/\vee</i>	L/J	CH \wedge/\vee	CH \wedge/\vee	CH \wedge/\vee	CH \wedge/\vee	CH \wedge/\vee	CH \wedge/\vee
<i>VOL \wedge/\vee</i>	VOL \wedge/\vee	VOL \wedge/\vee	VOL \wedge/\vee	VOL \wedge/\vee	VOL \wedge/\vee	VOL \wedge/\vee	VOL \wedge/\vee
<i>INPUT SELECT</i>	—	TV/VIDEO	—	TV/VIDEO	TV/VIDEO	TV/VIDEO	—

VCR OPERATING CONTROLS (continued)

Controlling a TV with the Remote Control

Only the remote control buttons that are used to control compatible television are described on this page. The buttons that are used to operate the VCR are described on pages 19-20.

If you have a compatible TV (other than TOSHIBA) you must program the remote control as described on the previous page before these buttons will operate your TV.

Depending on the specific features of your TV model, some of these controls may not apply to your TV. Check the chart to see which controls apply to your type of TV.

Most of the buttons (except *VOL* \wedge/\vee) will not control your TV unless the remote control is in the "TV mode". If you press the *VCR* button, the remote control will go into the "VCR mode" and control the VCR. Press the *TV* button to return the remote control to the "TV mode" so it will control the TV.

Important Note: When you press the *TV* button, this remote will automatically control your TOSHIBA TV. If your TOSHIBA TV stops responding to this remote, you may have accidentally pressed the buttons to program it for a different brand. To control your TOSHIBA TV again, press the *TV* button and number button "1" together as described on the previous page.

- ① **TV Button**
 - Press the *TV* button to put the remote control in the "TV mode", and then press the *POWER* button to turn on the TV.
- ② **POWER Button**
 - Press the *TV* button to put the remote control in the "TV mode", and then press the *POWER* button to turn on a compatible TV. The remote control must be programmed to operate a compatible TV (TOSHIBA or other).
 - Press *POWER* to turn off a compatible TV (TOSHIBA or other) when remote is in "TV mode".
- ③ **INPUT SELECT Button**

This button has the same function as some compatible TV's remote control *TV/VIDEO* button when the remote control is in the "TV mode".
- ④ **CHANNEL \wedge/\vee Buttons**

The remote control must be in the "TV mode" (press *TV* button) to use the *CHANNEL* \wedge/\vee buttons for your TV.

 - If your TV has a channel memory scan list, press *CHANNEL* \wedge to see the next higher channel in memory.
 - Press *CHANNEL* \vee to see the next lower channel in memory.

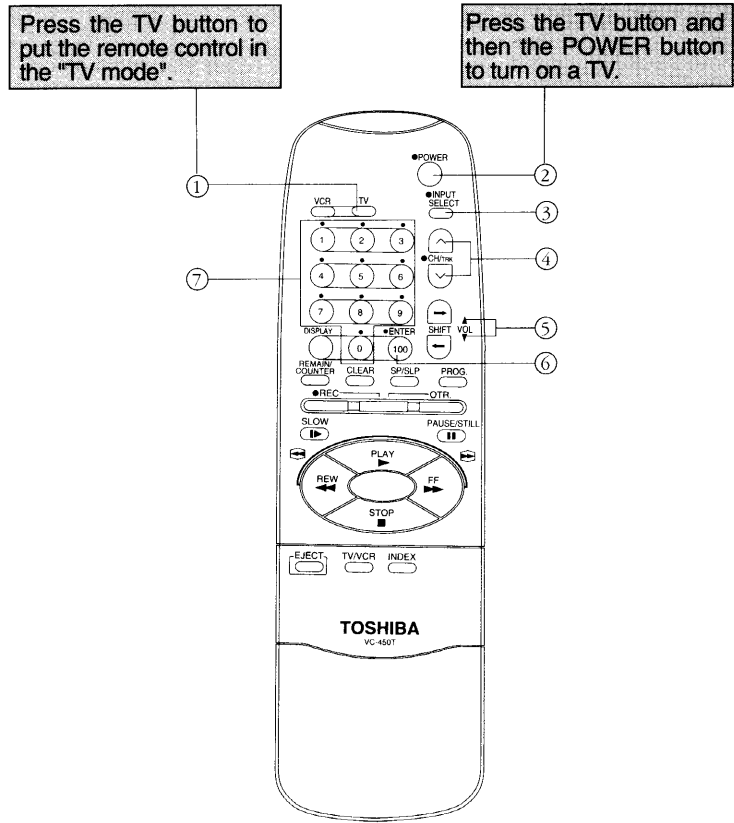

- ⑤ **VOL $\blacktriangle/\blacktriangledown$ Buttons**
 - Press *VOL* \blacktriangle to increase the volume.
 - Press *VOL* \blacktriangledown to decrease the volume.
- ⑥ **100 Button**

This button has the same function as some compatible TV's remote control *100 CH* or *ENTER* button when the remote control is in the "TV mode".
- ⑦ **Number Buttons ("0" through "9" and "100")**

The remote control must be in the "TV mode" (press *TV* button) to change channels on the TV.

 - Press two number buttons to select any channel (up to channel 99). For example, press "0" then "8" to select channel 8.
 - Press the "100" button and then two number buttons to select any cable-TV channel over 99. For example, press "100" then "0" then "8", to select channel 108.

VCR FEATURES

Quick-Play Feature

The quick-play feature eliminates the "delay" when you begin recording or playing back a tape. The VCR automatically positions the tape for "action" whenever a cassette is inserted or when the VCR is turned on with a cassette already inserted.

This VCR also keeps the tape "ready" when you place the VCR in the stop mode. This VCR has a high-speed rewind feature which eliminates a long wait.

Auto Head Cleaner

This VCR is equipped with an Auto Head Cleaner. This feature will ensure that your VCR will perform at its best by keeping the video heads clean of dirt that can distort picture quality. The Auto Head Cleaner engages automatically each time a tape is inserted or ejected.

VCR Function Set Up Menu

This VCR allows remote control adjustment of several additional feature options. You can use the VCR SETUP menu to select the functions that best fit your personal needs.

To display this menu, press PROG, then press "2" on the remote control.

The TAPE TYPES and COUNTER MEMORY features in the SETUP menu are necessary for initial installation of your VCR and are described on pages 13-14.

Three Language Menus

This VCR gives you complete control of all functions, programs, and displays in either English, French or Spanish.

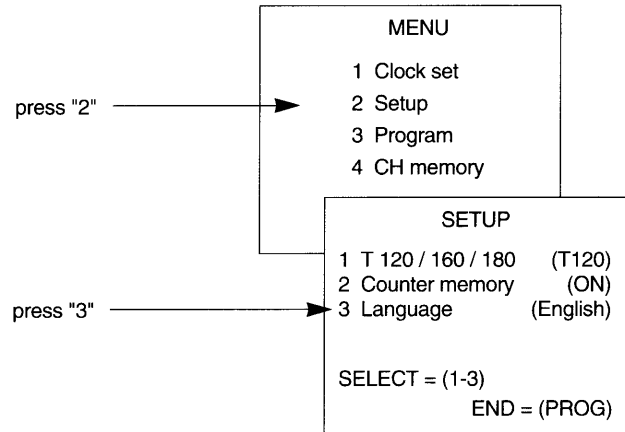

First Press PROG

Then
press "2"

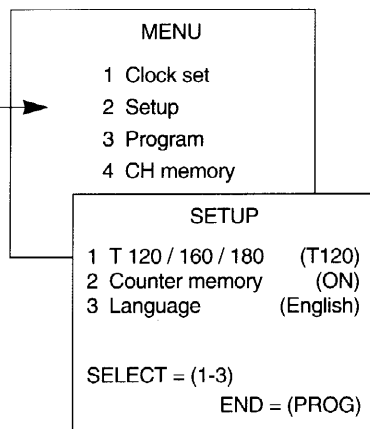

Set the following items :

1. T-120/160/180 (See page 24, 39.)
2. COUNTER MEMORY (See page 27.)
3. LANGUAGE

VIDEO CASSETTES

Use of poor quality tape or tapes that have been damaged or mishandled can contaminate the VCR heads. This can cause a snowy picture or a missing picture during playback. If a snowy or missing picture condition persists, consider the use of a chemical non-abrasive head cleaning tape.

Tape Speed

Recording: Tapes can be recorded at two different speeds, SP (Standard Play: records 3.34 cm/sec.) and SLP (Super Long Play: 1.11 cm/sec.). You may select the speed using the SP/SLP button. Selected speed mode will show up on the TV screen. The basic difference between these speeds is that the SLP mode allows you to get more pictures on your tape. Although this is economical, the quality of the image is not as good as recordings made in the SP mode.

Playback: There are three possible speeds for playback; SP, LP, SLP. The appropriate speed is chosen automatically by the VCR.

Speed	SLP	LP	SP
Mode			
Recording	YES	NO	YES
Playback	YES	YES	YES

Erasing Tapes

You can use your video cassettes over and over again. To erase a previous recording, just record over it.

Different types of cassettes and maximum recording times

Video Cassette Record Mode	T-180	T-160	T-120	T-60
SLP	540 min	480 min	360 min	180 min
SP	180 min	160 min	120 min	60 min

Record-Protect (Safety) Tab

To prevent erasing a recording you want to keep, remove the record-protect (safety) tab from the back of the cassette as shown below. Recording is impossible when this tab is removed. To record again on a cassette that has the tab removed, simply cover the hole with vinyl tape.

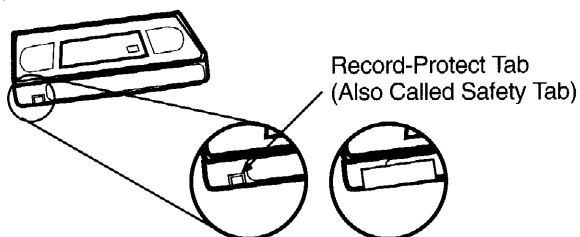

To prevent erasure, break off the tab.

To record again, cover the hole with vinyl tape.

Inserting and Removing Cassettes

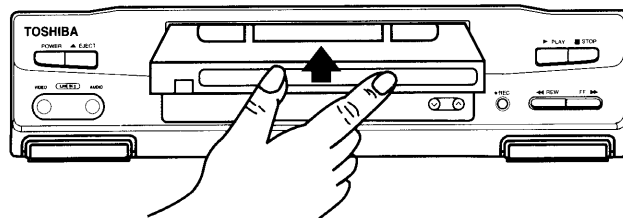

Insert a Cassette. Push the cassette gently through the door of the cassette compartment until the VCR mechanism pulls it into the VCR. Inserting a cassette will automatically turn on the VCR's power. The cassette-in indicator () will light when a cassette is properly inserted into the VCR.

Caution: Insert a cassette only one way with the tape window facing up, and the record-protect (safety) tab facing out.

EJECT Button STOP Button

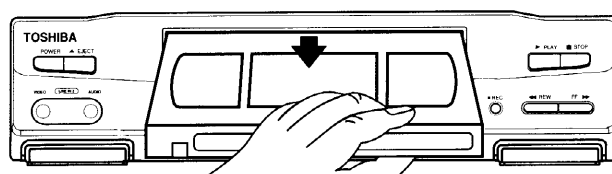

Eject and Remove a Cassette. The VCR must be in the stop mode. Press the *EJECT* button to eject the cassette. The cassette is partially ejected automatically by the VCR. Gently pull the cassette straight back out of the compartment. Place the cassette in its case and store it upright.

Cassette Care and Storage

Follow these directions for continued high-quality performance from your cassettes.

- When you are finished with a cassette, rewind it and remove it from the VCR.
- Never attempt to force open the cassette door.
- Store cassettes vertically in their protective cases at normal room temperatures. Avoid extreme heat and humidity. Extreme heat can warp the cassette or cause the tape to stretch excessively.
- Be especially careful to keep dust from entering the cassette and the VCR mechanism. All dust is abrasive and it will cause excessive wear of both the tape and the VCR's recording/playback heads.

PLAYBACK

Follow the steps below to play back a tape in the VCR. The VCR will automatically select the correct playback speed and the appropriate indicator will light in the VCR's display panel.

Some of the buttons on the VCR and remote control operate differently during playback. These special playback features are described on the following pages.

Playback Guide

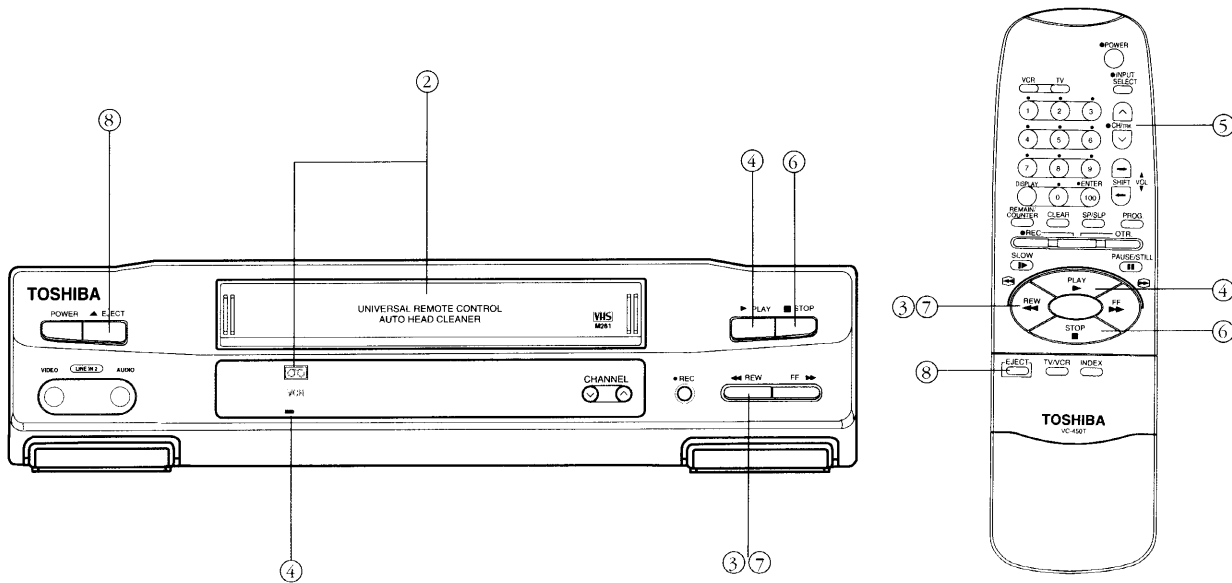

- ① Turn on the TV and tune it to the "VCR Channel" (3*, 4* or video input).
* The TV must be tuned to the same channel you selected with the CH3/CH4 switch on the back of the VCR.
- ② Insert a cassette in the VCR. (The cassette-in indicator will light.)
Note: The tape will automatically begin playback if the record protect (safety) tab on the cassette has been removed.
- ③ To rewind the tape if necessary, press the *REW* button on the VCR (or the *REW* button on the remote control).
- ④ To begin playback, press the *PLAY* button. The bar (■) indicators advance to the right in the display panel.
- ⑤ Adjust tracking if necessary. If the tape was recorded on a different VCR, streaks may appear. Press the *TRACKING* \wedge or \vee button on the remote control to move the streaks up or down out of the picture. *Details are on page 26.*
- ⑥ When you are finished, press the *STOP* button on the VCR (or the *STOP* button on the remote control).
- ⑦ To rewind the cassette, press the *REW* button on the VCR (or the *REW* button on the remote control).
- ⑧ To eject the cassette from the VCR, press the *EJECT* button on the VCR (or the *EJECT* button on the remote control) when it is in any mode except the record mode.

PLAYBACK (continued)

Picture Search

During playback, the rewind (*REW*) and fast forward (*FF*) buttons are used for visual searching of the tape.

- During playback, press and quickly release the *FF* button to visually search forward at 5 times normal speed (*SP* speed only). To return to normal playback, press the *PLAY* button again.
- During playback, press and quickly release the *REW* button to visually search backward at 5 times normal speed. To return to normal playback, press the *PLAY* button again.

The sound is turned off during visual searching because it would not be understandable at such high speed.

Expect to see some horizontal lines or bars in the picture when you are using the search mode. The picture will be best for tapes recorded at *SP* or *SLP* speed, although tapes recorded at *LP* speed can be viewed.

Accel Search

If you keep pressing the *FF* or *REW* button during playback or picture search, the searching speed will be increased to 9 times (*SP* speed only) or 27 times (*SLP* speed only) normal speed.

Slow-Motion Playback

The tape can be viewed in slow motion during playback.

- Press the *SLOW* button on the remote control when a tape is playing to start slow-motion playback. Press the *PLAY* button to return to normal playback.
- During slow-motion playback, you can change the speed by pressing the *SLOW* button on the remote control. Press the *SLOW* button again to change the speed from 1/15 times to 1/7 times normal speed.

It is normal to see some streaks in the picture during slow motion playback. Press the *TRACKING* \wedge or \vee button on the remote control to move the streaks up or down and out of the picture.

The VCR will automatically switch from slow-motion to stop after about five minutes.

Note :

- Slow-motion playback is designed to work best at the *SLP* speeds. It is normal the picture quality at the *SP* speed is not good.

Still for Stop-Action Playback

- Press the *PAUSE / STILL* button during playback to freeze the picture. This lets you examine all the details of the scene, similar to looking at a single frame of a movie film.
- When you are ready to resume normal playback, press the *PAUSE / STILL* button again.

Note :

- Still frame is designed to work best at the *SLP* speed. It is normal the picture quality at the *SP* speed is not good.

- If the picture "jitters" (bounces up and down) during still, press one of the *TRACKING* \wedge and \vee buttons located on the remote control to reduce the "jitter".

Caution: Using still frame on a single frame of the picture for a long time can wear the tape. Use *STOP* instead of *STILL* to interrupt playback for an extended time. The VCR will automatically switch from pause to stop after about five minutes.

Frame Advance

Frame advance lets you view one still frame after another.

- Press the *PAUSE/STILL* button to begin stop-action viewing. Then press the *PLAY* button on the remote control each time you want to view the next frame for the scene. Press the *PAUSE/STILL* button to resume playback at normal speed.

Note :

- Frame advance is designed to work best at the *SLP* speed. It is normal the picture quality at the *SP* speed is not good.

Tracking (Automatic and Manual)

The VCR has a built-in digital automatic tracking feature and there are manual *TRACKING* buttons on the remote control.

Digital Auto Tracking

The VCR automatically adjusts the tracking for rental tapes or tapes recorded on other VCRs or camcorders.

- Every time you insert a tape and press the *PLAY* button, the VCR's digital auto tracking is turned on and tracking is adjusted.
- If you press one of the manual *TRACKING* buttons on the remote control, the digital auto tracking feature is turned off before the tape speed is changed (if tape speed is changed, the digital auto tracking feature is turned on again).

Manual Tracking (*TRACKING* \wedge and \vee Buttons)

Tracking can be adjusted manually by pressing the *TRACKING* \vee or \wedge button on the remote control.

- During still playback, press the *TRACKING* \wedge or \vee button to reduce picture "jitter" (bouncing up and down). A small amount of "jitter" or some "steaks" are normal during still viewing.
- During slow-motion playback, it is normal to see some streaks (noise bars) in the picture. If the streaks interfere with the time counter display on the TV screen, press the *TRACKING* \wedge or \vee button to move the streaks up or down.

Note :

- When a tape recorded with another VCR or a tape recorded with this VCR at the *SP* speed is played back at slow or still frame, noise may not be eliminated by *TRACKING* control.

PLAYBACK (continued)

On-Screen Displays

The VCR's on-screen displays appear automatically on the TV whenever you turn on the VCR or change the VCR's status (stop to play, play to stop, change channels, etc.). The VCR's on-screen displays or the time counter can be manually displayed by pressing the *DISPLAY* button on the remote control.

- Press the *DISPLAY* button once to display the normal displays on the TV screen.
- Press the *DISPLAY* button again (while the normal displays still appear on the TV screen) to display only the time counter on the TV screen. The time counter will remain on the TV screen.

Note: Whenever the time counter with memory appears on the TV screen, the time counter's memory stop feature is automatically turned on.

- Press the *DISPLAY* button again to display only the remain counter on the TV screen.
- Press the *DISPLAY* button again to remove all displays from the TV screen.

Time Counter with Memory-Stop Feature

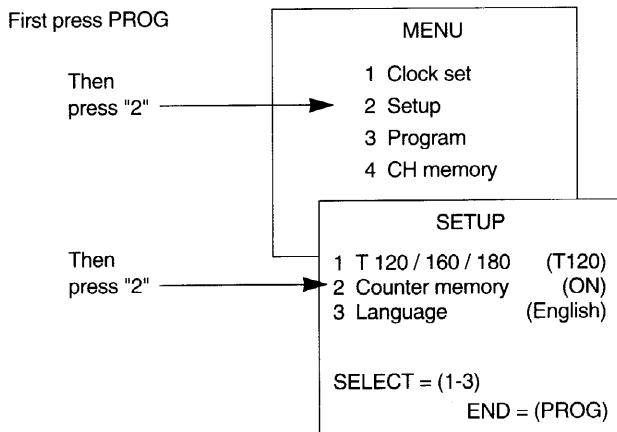

The time-counter display shows the actual linear time it takes to record a program or play back a segment of a pre-recorded tape. It helps you quickly locate the start of programs you taped. For example, if you recorded a 30-minute program at one segment of the tape, you will be able to stop the tape, display the time counter with memory, and rewind the tape until the time counter reads "0:00:00M" on the TV screen (in the VCR's display panel). This will be the approximate start position of your 30-minute recording.

- If the current time appears in the VCR's display panel, press the *DISPLAY* button twice to switch the current time display to the time-counter display.
- Then press the *DISPLAY* button again to display the remain counter on the TV screen.
- Then press the *DISPLAY* button again to display the time counter on the VCR's display panel.

Whenever the time counter with memory is displayed, press the *CLEAR* button on the remote control to set the time counter to a reading of "0:00:00M"

Notes: The time counter is automatically reset to "0:00:00" in the VCR's display panel whenever the tape is ejected from the VCR.

If you rewind the tape farther back than a counter reading of "0:00:00", a minus(-) will appear in front of the time.

Memory-Stop Feature (Zero Return)

The memory-stop feature allows you to quickly return to a counter reading of "0:00:00" from any point on the tape. Memory stop is automatically turned on whenever the time counter with memory is displayed on the TV screen. This is convenient when you want to watch a segment of the tape repeatedly. You may also discover other useful applications for this feature.

1. To turn on the memory-stop feature, press the *DISPLAY* button on the remote control to display the time counter with memory on the TV screen. The time counter will appear with an M on the TV screen when memory stop is turned on.
2. Whenever you are at a spot on the tape that you want to return to quickly, press the *CLEAR* button to reset the counter to "0:00:00M" at the spot.
3. Later, after you have moved somewhere else on the tape, you can quickly return to your original spot (where you set the counter to "0:00:00M") by pressing the *STOP* and then the *REW* or *FF* (fast-forward) button. Make sure the "M" is displayed if you want the VCR to stop at "0:00:00".

Notes: If you are rewinding the tape and the VCR stops at "0:00:00M", press *REW* again to continue rewinding.

If you press the *FF* (fast-forward) button and the time counter never reaches "0:00:00M" between that point and the end of the tape, the VCR will continue to fastforward to the end of the tape.

RECORDING

Recording Guides

The guides on these two pages show you how to make recordings on the VCR.

- The guide on the bottom of this page shows you how to record on the VCR with the TV turned off.
- The first guide on the next page shows you how to record a program on the VCR and watch the same program on the TV.
- The second guide on the next page shows you how to record one program on the VCR while watching a different program on the TV.

This VCR also features One Touch Recording (OTR) and timer recording. It will turn itself on, make a recording, and turn itself off while you are away.

- *Details on One Touch Recording (OTR) are on page 30.*
- *Details on timer recording are on pages 31-34.*

PAUSE/STILL Button

Use this button to stop recording temporarily. This enables you to skip recording unnecessary parts of a program (such as commercial messages).

1. Press the **PAUSE/STILL** button during recording and recording is stopped temporarily. However, since the TV continues operating, the pictures and sound of the program can be received.
2. Press the **PAUSE/STILL** button to resume recording.

Note: If the VCR pauses for more than five minutes, it automatically enters the stop mode to protect the tape.

Recording With TV Turned Off

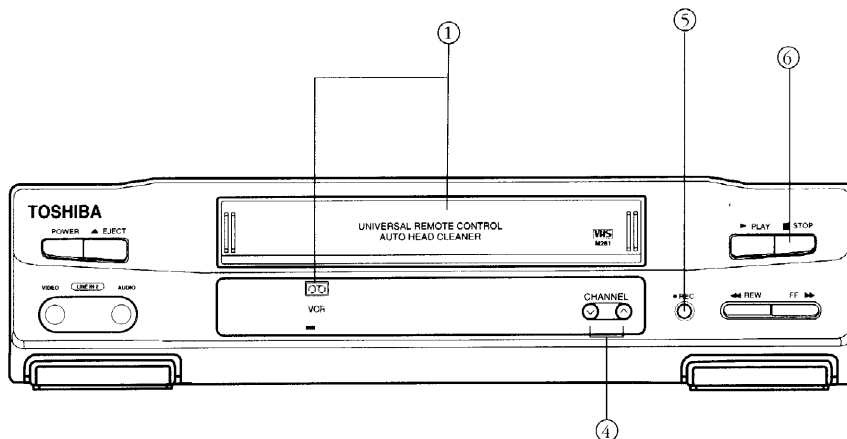

1. Insert a cassette with the Record-Protect (safety) Tab intact. The cassette-in indicator will light.
2. Press the **SP/SLP** button to select a recording speed. The tape speed indicator (**SP** or **SLP**) will appear.
3. Make sure the "L1(2)" indicator does not appear in the VCR's display panel unless you want to record from the VCR's **AUDIO** and **VIDEO IN** jacks. If "L1(2)" appears, press the **INPUT SELECT** button to turn it off.

Tape Recording Speeds

To select one of the VCR's two recording speeds, press the **SP/SLP** button. The appropriate indicator (**SP** or **SLP**) will appear in the VCR's display panel. The information below will help you decide which tape speed to use when recording.

Notes: The VCR automatically selects the appropriate tape speed for playback.

Your VCR's special effects (still-frame and search) are designed for optimum performance at the **SLP** speed.

We recommend **SLP** speed for the longest recording time.

- **SP** (Standard play) provides the best picture but the shortest recording time (2 hours with a T-120 tape). Video recorded at this speed has the least picture noise (snow) in normal playback.
- **SLP** (Super Long Play) provides three times the recording time as **SP** (6 hours with a T-120 tape). **SLP** has slightly more picture noise (snow) than **SP** in normal playback. This may not be noticeable.

Press VCR button to put remote in "VCR" mode

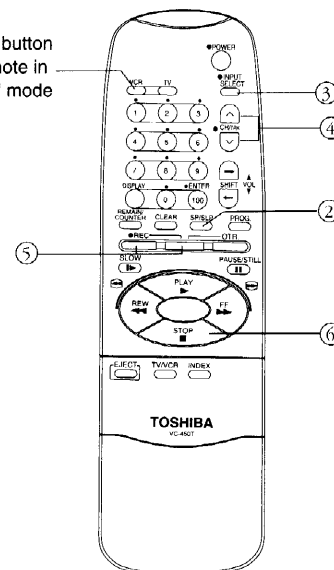

4. To select the channel you want to record, press the **CHANNEL** \vee or \wedge button until the channel number you desire appears.
5. To start recording, press the **REC** and dummy button. The record indicator appears in the VCR's display panel.
6. When you finished, press the **STOP** button on the VCR (or the **STOP** button on the remote control).

RECORDING (continued)

Recording and Viewing the Same Program

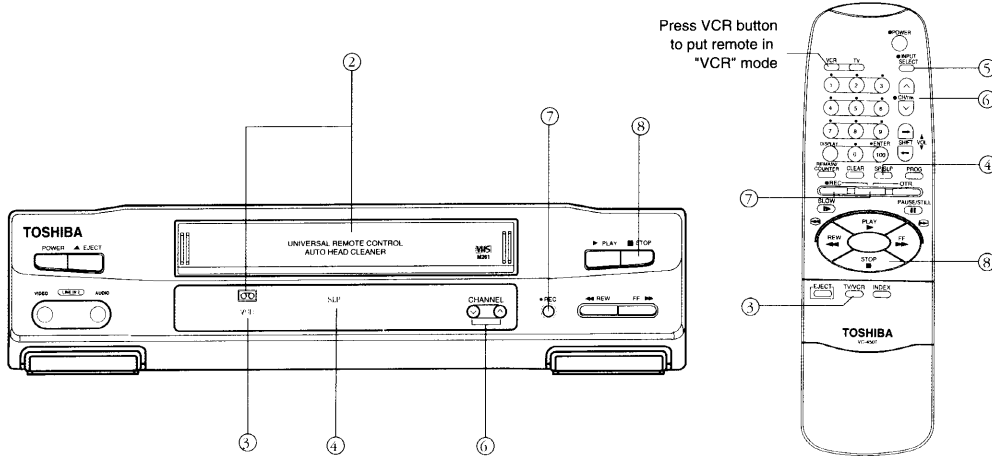

- ① Turn on the TV and tune it to the "VCR Channel" (3*, 4* or video input).
* The TV must be tuned to the same channel you selected with the CH3/CH4 switch on the back of the VCR.
- ② Insert a cassette with the record-protect (safety) tab intact. (The cassette-in indicator will light).
- ③ Make sure the VCR indicator appears in the VCR's display panel. If it does not appear, press the TV/VCR button to turn it on.
- ④ Press the SP/SLP button to select a recording speed. The tape speed indicator (SP or SLP) will appear.
- ⑤ Make sure the "L1(2)" indicator does not appear in the VCR's display panel unless you want to record from the VCR's AUDIO and VIDEO IN jacks. If "L1(2)" appears, press the INPUT SELECT button to turn it off.
- ⑥ Press the CHANNEL ∇ or \blacktriangle button to select the channel you want to record. (The channel number appears in the VCR's display panel).
- ⑦ Press the REC button to start recording. (The recording indicator appears in the VCR's display panel).
- ⑧ Press the STOP button on the VCR (or the STOP button on the remote control) when you are finished.

Recording and Viewing Different Programs

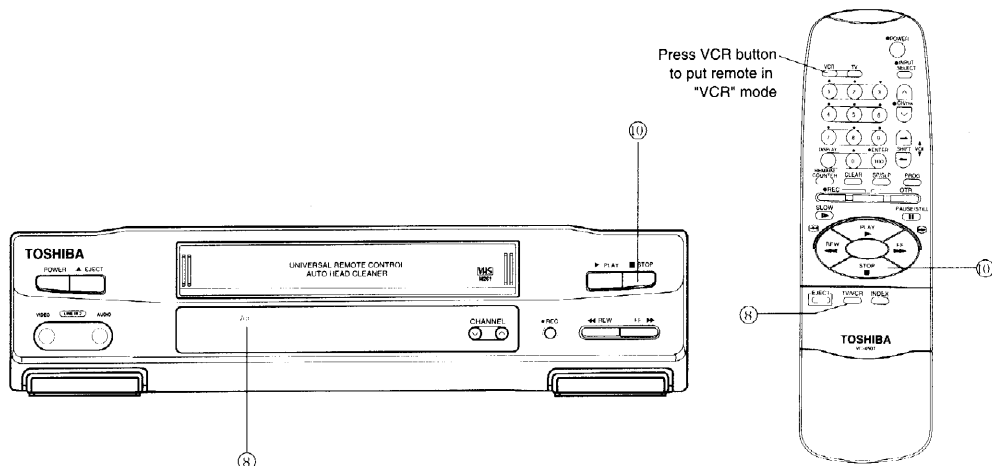

To record one program on the VCR and watch a different program on the TV, follow steps ① through ⑦ above and then :

- ⑧ Press the TV/VCR button to turn off the VCR indicator.
- ⑨ Select other channel you want to watch with the TV's channel buttons.
- ⑩ Press the STOP button on the VCR (or the STOP button on the remote control) when you are finished.

Note: If you want to watch what the VCR is recording, press the TV/VCR button to turn on the VCR indicator. Then tune your TV to the "VCR Channel" (3,4, or video input).

Notes:

- Basic Manual Recording is possible only in the SP and SLP modes.
- The recorded pictures on the tape may be distorted around where the PAUSE/STILL button is used. This is not a malfunction.
- Since channel lock function operates during recording, TV channels cannot be changed directly. To change the channel, press the PAUSE/STILL button first. If the PAUSE/STILL button is pressed again, a TV program on a new channel can be recorded.

RECORDING (continued)

One Touch Recording (OTR)

One Touch Recording (OTR) lets you record up to four hours without programming the timer. It also allows you to start (or continue) recording immediately.

When the recording is finished, the VCR will turn off automatically.

Note: The clock doesn't have to be set before you can do One Touch Recording.

Only two buttons on the remote control are used to do One Touch Recording.

Immediate Start

- If you want the VCR to start recording immediately or to continue a recording you have already started, *follow the simplified instructions below or the detailed instructions on the right-side page.*
- Only the *OTR* buttons are used for immediate One touch Recording. Each time you press the *OTR* buttons the recording time is extended.

1st press.....	30 minutes OTR
2nd press.....	1 hour OTR
3rd press.....	1-1/2 hours OTR
4th press.....	2 hours OTR
5th press.....	2-1/2 hours OTR
6th press.....	3 hours OTR
7th press.....	3-1/2 hours OTR
8th press.....	4 hours OTR
9th press.....	Return to normal recording

Simplified Instructions for Immediate-Start

1. Turn on the VCR.
2. Insert a cassette with the record-protect (safety) tab intact. (Rewind if necessary).
3. Select the channel you wish to record.
4. Press the *OTR* buttons to select desired recording time ["0:30" (30 minutes) to "4:00" (4 hours)]

To Stop OTR After Recording Starts

- Repeatedly press the *OTR* buttons until normal recording returns. Then press the *STOP* button during the normal recording.
- Press the *POWER* button on the VCR set.

RECORDING (continued)

Programming the Timer

The programmable clock/timer permits unattended recording of up to eight different TV programs. The timer is actually a small computer which will automatically turn on the VCR at the time you select, record for a selected length of time, and then turn off the VCR.

You can program the timer to do the following:

- Record a program on a single day up to one year away (*ONE TIME PROGRAM*).
- Record a program at the same time Monday through Friday (*DAILY PROGRAM*).
- Record a program on one certain day and time of every week (*WEEKLY PROGRAM*).

Simplified Programming Instructions

1. Turn on the TV and tune it to your "VCR Channel" (3, 4 or video input).

2. Turn on the VCR or insert a cassette with the record-protect (safety) tab intact. (Rewind if necessary).
3. Press the *PROG* button on the remote control.
4. Watch the display on the TV screen. It will prompt you through the rest of the programming instructions.
5. **Turn off the VCR.** The VCR must be turned off for the timer program to begin.

Things to know before you start:

- The time and date must be correct before you program the timer.
- You can program the timer up to one year before the TV program is to be recorded.
- You can correct an error in the program any time by pressing the *SHIFT* ← → button on the remote control.
- You should press *PROG* button for confirming the timer program before power off.

<p>[1] Press <i>PROG</i> on the remote. The program menu appears on the TV screen.</p>	<pre style="text-align: center;"> MENU 1. Clock set 2. Setup 3. Program 4. CH memory SELECT=(1-4) END=(PROG) </pre>
<p>[2] Press 3 to select the timer program. The program list from 1 to 4 appears.</p> <p>Note: You can select 1-8. If you press 5~8, the next program (5-8) list appears.</p>	<pre style="text-align: center;"> NO CH DATE ON OFF 1 2 3 4 SELECT=(1-8) END=(PROG) </pre>
<p>[3] Press 1 through 8 to select the record timer program number.</p>	<pre style="text-align: center;"> PROG1 12:01p 3. 11 '95 SA CH DATE ON OFF X- 3. 11 '95 -:-a -:- MO SLP CORRECT=(←) (→) END=(PROG) </pre>
<p>[4] Enter channel you want to record.</p> <p>NOTE: If you wish to record from the Cable-TV, first set the channel into the channel set mode. (See page 13.)</p> <p>The display will prompt you to select a channel number.</p>	<pre style="text-align: center;"> PROG1 12:01p 3. 11 '95 SA CH DATE ON OFF 2 3 11 '95 -:-a -:- MO SLP DAILY/WEEKLY=PUSH (100) CORRECT=(←) (→) END=(PROG) </pre>

RECORDING (continued)

<p>[5] Enter date. Note: Always press "0" before a single digit month or day. If you wish to select the daily/weekly programming, press 100. The daily/weekly programming menu will appear.</p>	<div style="border: 1px solid black; padding: 5px;"> <p>1 Every sunday 2 Every monday 3 Every tuesday 4 Every wednesday 5 Every thursday 6 Every friday 7 Every saturday 8 Monday to friday SELECT=(1-8)</p> </div>
<p>[6] Select 8 if you want to record daily programming.</p>	<div style="border: 1px solid black; padding: 5px;"> <p>PROG1 12:01p 3. 11 '96 MO CH DATE ON OFF 2 MO \:--- a --- →FR SLP CORRECT=(←) (→) END=(PROG)</p> </div>
<p>[7] Enter start time.</p>	<div style="border: 1px solid black; padding: 5px;"> <p>PROG1 12:01p 3. 11 '96 MO CH DATE ON OFF 2 MO 12:00 a --- →FR SLP am=(1) pm=(2) CORRECT=(←) (→) END=(PROG)</p> </div>
<p>[8] Press 1 to select AM or 2 to select PM. Note: Noon is 12 PM Midnight is 12 AM</p>	<div style="border: 1px solid black; padding: 5px;"> <p>PROG1 12:01p 3. 11 '96 MO CH DATE ON OFF 2 MO 12:00 p \:--- →FR SLP CORRECT=(←) (→) END=(PROG)</p> </div>
<p>[9] Enter end time. AM or PM is automatically set after you enter the end time. AM or PM of end time is determined within 12 hours of start time.</p>	<div style="border: 1px solid black; padding: 5px;"> <p>PROG1 12:01p 3. 11 '96 MO CH DATE ON OFF 2 MO 12:00 p 12:30 →FR SLP SP=(1) SLP=(2) AUTO=(3) CORRECT=(←) (→) END=(PROG)</p> </div>
<p>[10] Press the SP/SLP button to select the tape speed. If the tape length may not be long enough for timer recording in the SP mode, set the recording speed to AUTO at this step. Recording starts in the SP mode and the VCR automatically selects the tape speed to record the program to the end. If the tape length is not long enough, the tape speed automatically changes from the SP mode to the SLP mode. The Power Off Message appears on the TV screen.</p>	<div style="border: 1px solid black; padding: 5px;"> <p>Remember to check tape and turn VCR power off for timer recording</p> </div>

RECORDING (continued)

Checking Timer Programs

Programs can be checked whenever the VCR is turned on.

1. Press the *PROG* button on the remote control to display the program menu.
2. Press number button "3" for PROGRAM. The TV screen will display the information you entered for the 1-4 program for a few seconds.
3. Press 5-8 buttons if you want to view the next program information.

Timer Recording From the VCR's Line Input (AUDIO and VIDEO IN Jacks)

It is also possible to timer record from a device connected to the VCR's *AUDIO* and *VIDEO IN* jacks (called "line input"). To enter the channel for the timer recording, press *INPUT SELECT* button. The "L1(L2)" indicator appears in the VCR's display panel, and *LINE1(2)* appears instead of the channel number on the TV screen. This is convenient if you have a satellite receiver or similar device attached to the *AUDIO* and *VIDEO IN* jacks on the VCR.

If You are Programming More Than 8 Programs

When you press *PROG*, "All programs are full" appears on the screen. If you want to replace one program with another, press *PROG* to check timer program listing. If you don't want to, press the *PROG* button to finish programming.

Clearing a Timer Program

1. Press the *PROG* button on the remote control to display the program menu.
2. Press number button "3" to select *PROGRAM*. The TV screen will display the information you entered for the 1-4 program for a few seconds.
3. Press 5-8 buttons if you want to view the next program information.
4. Press the number button on the remote control to select the program you want to clear.
5. Press the *CLEAR* (program) button to remove the program from the TV screen.
6. Press the *PROG* button to remove the program menu from the TV screen.

Stopping a Timer Recording in Progress

Press the *POWER* button on the VCR to stop a Timer Recording in progress.

Notes: ONE TIME PROGRAMS clear automatically when the recording is finished.

Daily and weekly programs remain in the timer indefinitely.

All programs are erased if power is interrupted for an extended period (about one minute).

Notes:

- Set the tape speed according to the tape remaining time.
 - When the remaining tape amount is small compared with the reserved recording time and the timer recording starts in the *SLP* mode from the beginning, the recording is not completed to the end.
 - The picture will be distorted when playing back the part where the recording mode was switched over from the *SP* mode to *SLP* mode with the *AUTO* tape speed recording method.
-

RECORDING (continued)

Timer Recording

The information on this page tells you how to set up your VCR for timer recording after you have programmed the timer.

The programming instructions for time programming are on pages 31-33.

When you have finished programming the timer, follow the steps in the drawing to prepare the VCR for timer recording. We suggest that you make one or more short timer recordings for practice.

If you have a daily or weekly program in the VCR's timer, check the steps in the drawing sometime before the recording time to be sure that your VCR is ready to record.

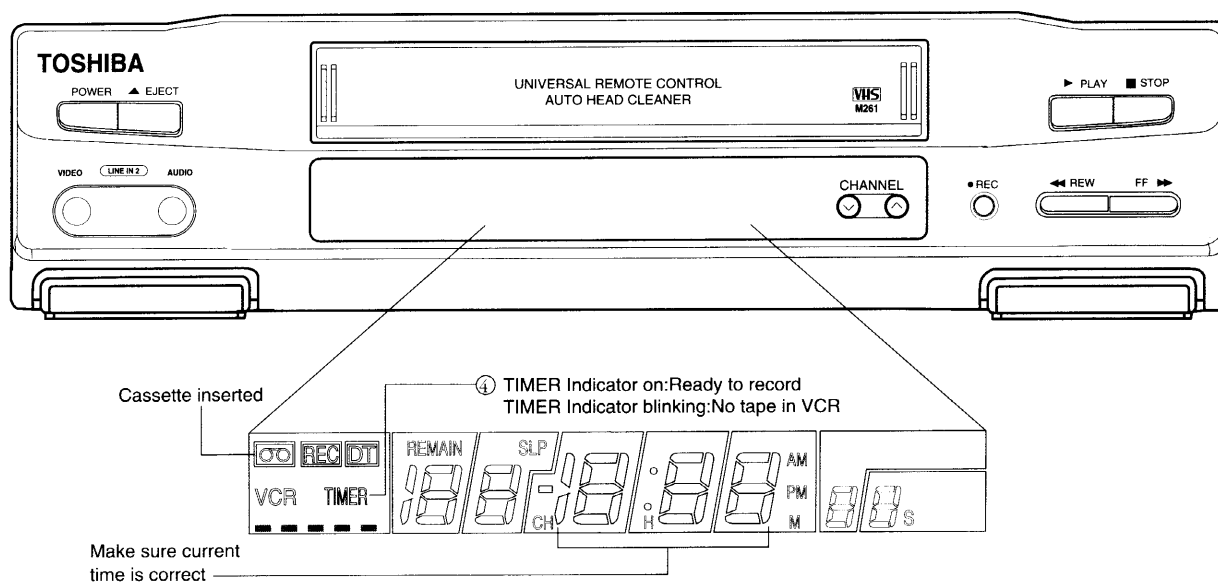

① Set the clock. See page 14.

② Insert a cassette with the record-protect(safety) tab intact. (Rewind if necessary.)

③ **TURN OFF VCR.** The VCR must be off to activate the timer.

④ Check VCR's display panel.

Timer Recording Checklist

The checklist below is provided for your use when making time recordings on the VCR.

- Cassette inserted in the VCR.
- Cassette has its record-protect (safety) tab in place. If not, the cassette is ejected. See "Erase Protection" on page 24.
- Cassette length and recording speed are adequate for program(s) to be recorded.
- Cassette rewound to beginning or to desired place on tape.
- Clock set to correct time and date.
- Timer has been programmed as described on pages 31-33.
- VCR has been turned off. The TIMER indicator appears only if the timer is programmed and the VCR is turned off.

Timer and OTR Recording

The timer cannot begin recording if the VCR is already recording with OTR. You can OTR along with timer recording, but be careful that the programming times of the OTR and timer recordings do not overlap. If this should happen, the function selected in advance will take priority.

TV Viewing During a Timer Recording

When the VCR turns on automatically to make a timer recording, it does not disturb whatever program you may be watching at the time. If you want to monitor the recording, press the TV/VCR button to turn on the VCR indicator and tune your TV to the "VCR Channel" (3, 4 or video input).

Stopping a Timer Recording in Progress

Press the POWER button on the VCR to stop a Timer Recording in progress.

RECORDING (continued)

Recording From a Camcorder

To duplicate tapes using your camcorder, connect your camcorder to the VCR as shown below. You will need an output cable (usually supplied with the camcorder).

- ① Connect the *VIDEO* plug from the output cable to the *VIDEO IN* jack on the front or the rear of the VCR.
- ② Connect the *AUDIO* plug from the output cable to the *AUDIO IN L/MONO* jack on the front or the rear of the VCR.
- ③ Connect the other end of the output cable to the *AUDIO/VIDEO OUT* connectors on the camcorder.

Caution: The unauthorized recording of television programs and other material may infringe the rights of others.

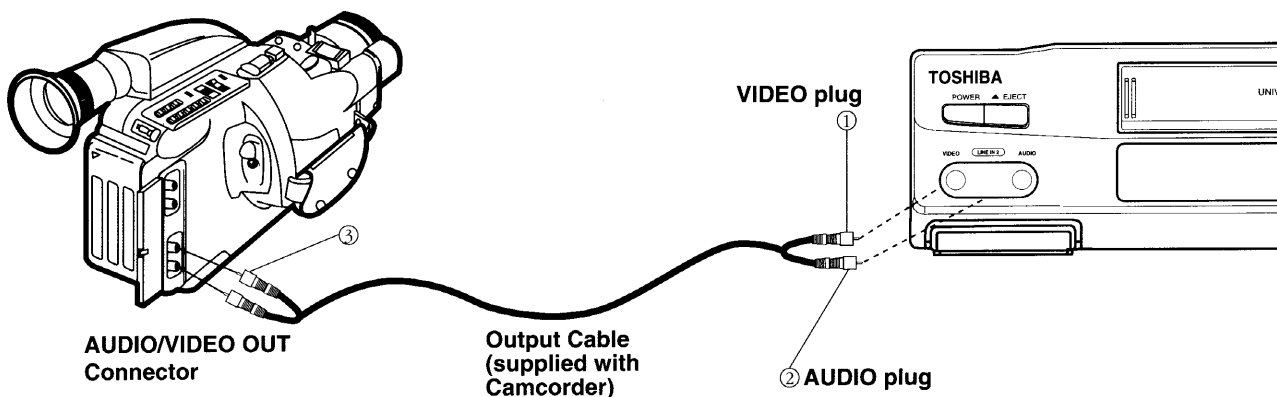

VHS CAMCORDER

Simplified Operating Instructions

1. Connect the camcorder to the VCR as shown above.
2. Turn on the TV and tune it to the "VCR Channel" (3, 4 or video input.)
3. Turn on the camcorder and VCR.
4. Insert the recorded cassette that you want to duplicate in the camcorder.
5. Insert a blank cassette with its record-protect (safety) tab intact into the VCR.
6. Make sure the VCR indicator appears in the VCR's display panel. If not, press the *TV/VCR* button to turn it on.
7. Make sure the "L2" indicator appears in the VCR's display panel. If not, press the *INPUT SELECT* button to turn it on.
8. Select the tape recording speed (*SP* or *SLP*) by pressing the *SP/SLP* button.
9. Rewind the cassettes if necessary.
10. Press the *REC* button on the VCR or on the Remote Control.
11. Place the camcorder in the playback mode and press the *PLAY* button.
12. Adjust the *TRACKING* control on the camcorder, if necessary.

Note: If the cassette tracking was not adjusted correctly on the camcorder, horizontal streaks may appear in the picture.

13. If you want to edit out any of the material, press the *PAUSE/STILL* button on the VCR's remote control. Press the *PAUSE/STILL* button again to resume recording.

Note: Use *PAUSE/STILL* only for pauses less than three or four minutes. Press the *STOP* button on the VCR (or the *STOP* button on the VCR's remote control) for longer pauses. Press the *REC* button on the VCR to resume recording.

14. Stop the camcorder and VCR when you are finished.

Note: The TV does not have to be on to copy tapes. If you want to watch another TV channel, press the *TV/VCR* button to turn off the VCR indicator. Then select the channel you want to watch with the TV's channel buttons.

Remember: Turn off the "L2" indicator for normal recording from the VCR's tuner.

RECORDING (continued)

Recording From Another VCR

To copy your home videos from one VCR to another, use one VCR as the playback VCR and another VCR as the recording VCR.

Connecting the VCRs

1. Connect a shielded Audio/Video cable from the *VIDEO OUT* jack on the playback VCR to the *VIDEO IN* jack on the recording VCR.
2. Connect another cable from the *AUDIO OUT* jack on the playback VCR to the *AUDIO IN* jack on the recording VCR.

Important Note: Be sure that the recording VCR is connected to the TV so that you can see what is being recorded. This can be done either by connecting the *VIDEO* and *AUDIO OUT* jacks of the recording VCR to the *VIDEO* and *AUDIO IN* jacks of the TV or by connecting the *OUT TO TV* jack on the recording VCR to the *VHF IN* jack on the TV.

Caution: The unauthorized recording of television programs and other material may infringe the rights of others.

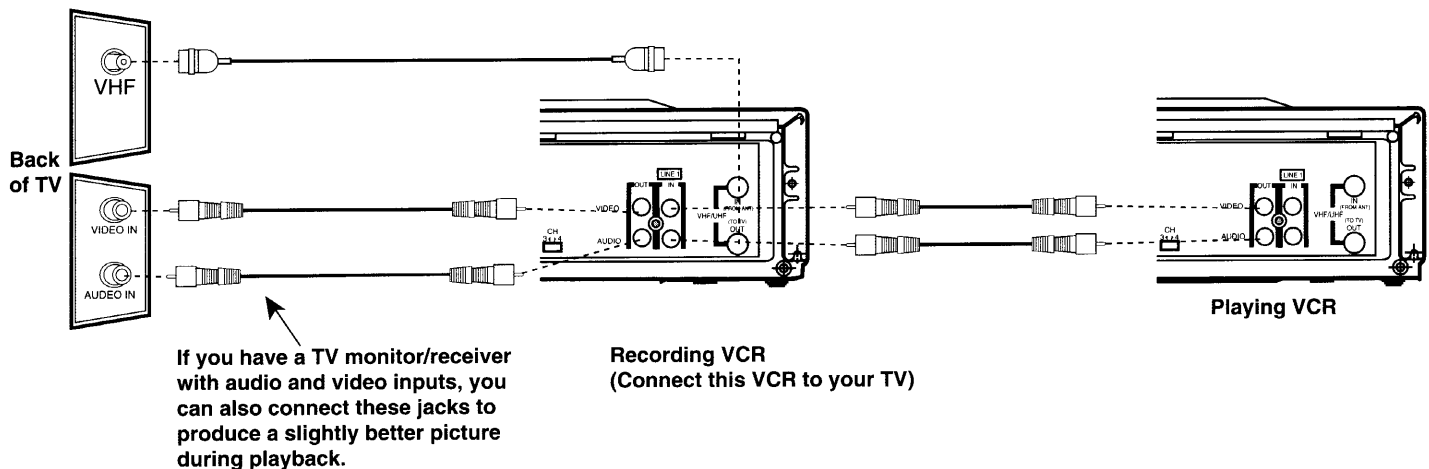

Copying Your Home Video

1. Turn on the TV and VCRs. Tune the TV to the "VCR Channel" (3, 4 or video input).

Note: If you are using channel 3 or 4 on your TV to watch the VCR, be sure the VCR indicator in the recording VCR's panel is on. Press the *TV/VCR* button to turn it on.

2. Press the *INPUT SELECT* button to turn on the "L1" indicator in the recording VCR's display panel.
3. Insert the home video that you want to copy into the playback VCR. Insert a blank tape into the recording VCR.
4. Press the *PLAY* button on the playback VCR to play the tape. Press the *PAUSE/STILL* button of the playback VCR when you reach the point where you want to begin copying.

Note: If the tape tracking was not adjusted properly on the playback VCR, horizontal streaks may appear in the picture. You may need to adjust the tracking on the playback VCR.

5. Press the *REC* button on the recording VCR, and then press the *PAUSE/STILL* button to place the recording VCR in the record pause mode.
6. Press the *PAUSE/STILL* buttons on **both VCRs at the same time** to begin copying the tape.

Note: You can edit out segments that you do not want to copy by pressing the *PAUSE/STILL* button of the recording VCR at any time to stop copying the tape. Locate the next segment you want to copy on the playback VCR by using the *FF*, *REW*, and *PLAY* buttons. Then place the playback VCR in the play-pause mode by pressing its *PAUSE/STILL* button. Press the *PAUSE/STILL* buttons **at the same time on both VCRs** to resume copying.

7. Press the *STOP* buttons on both VCRs when you are finished.

Note: Remember to turn off the "L1" indicator in the VCR's display panel for normal recording from the VCR's tuner.

Caution: Avoid pausing for more than three or four minutes because the spinning heads that do the recording are still in contact with the tape and will eventually wear off the active material. This can cause streaks or spots in the picture when you play the worn part of the tape (called dropouts). To help prevent excessive tape wear, the VCR will automatically switch from pause to stop after about five minutes.

SPECIALIZED OPERATIONS

Index

You can easily search for the recorded program using the index signal registered together with it on the tape.

• Scan and Play Index Playback

This function plays back the tape around where the index signal is registered for about 6 seconds while fast forwarding or rewinding. (This function is operable using the remote control.)

Index Register

There are two ways to register INDEX signals: automatically and manually.

• Auto Register

Press the *REC* button during the stop mode and the index signals are registered automatically.

Auto register can be operated during one touch timer recording (OTR) or timer programming recording.

• Manual Register (using the remote control)

During recording, index signals can be registered at the desired sections of the tape by pressing the INDEX button on the remote control.

Notes:

- When registering index signals on tape recorded on other VCRs, its pictures may be distorted.
- When you start index playback at the beginning or at the end of the tape, the first index mark on the tape might be skipped by the VCR.
- When registering index signals at 2 or more sections on the tape, certain intervals may be needed: more than 1 min. in SP mode and more than 3 min. in SLP mode.
- Index signal may not find the correct position in accordance with the tape condition.

Scan and Play (Index Playback)

(Remote Control)

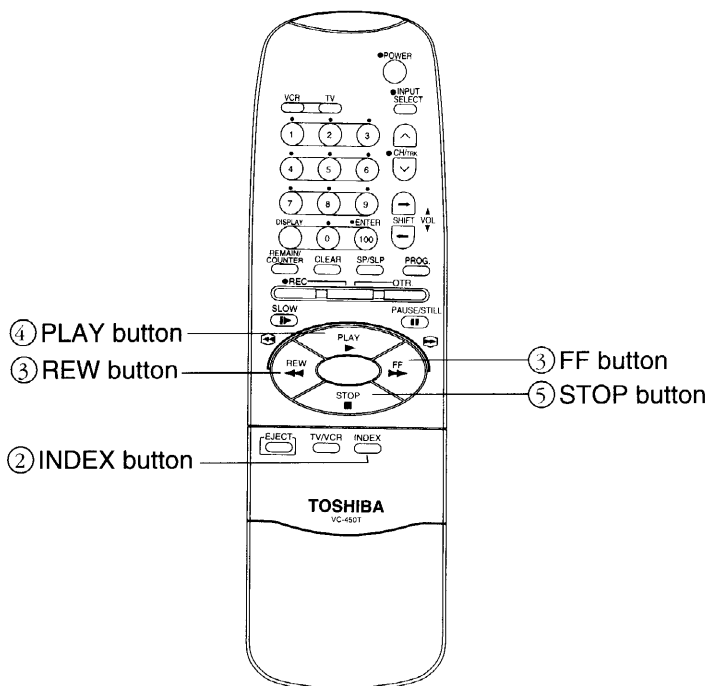

- ① Load the tape with index signals, then play back or stop it depending on preference.

- ② Press the *INDEX* button.

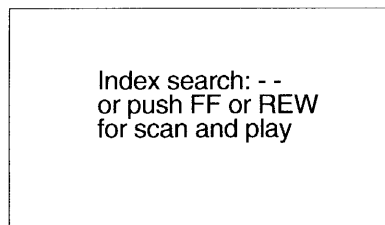

- ③ Press either the *FF* button or *REW* button within 9 seconds.
 - Press *FF* to search ahead.
 - Press *REW* to search behind.

The VCR starts to fast forward or rewind the tape, playing it back for 6 seconds around the section where the index signal is registered. This operation is repeated until the end of the tape is reached.

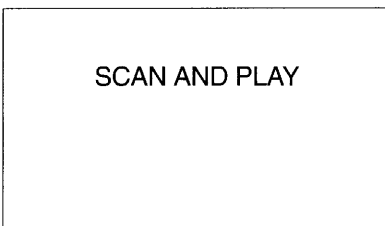

- ④ Press the *PLAY* button when the desired program is located. "SCAN AND PLAY" on the screen goes off.

If the button is not pressed, fast forwarding or rewinding resumes while the next index signal is being searched.

- ⑤ Press the *STOP* button to stop playback.

SPECIALIZED OPERATIONS (continued)

Skip Search (Index Playback)

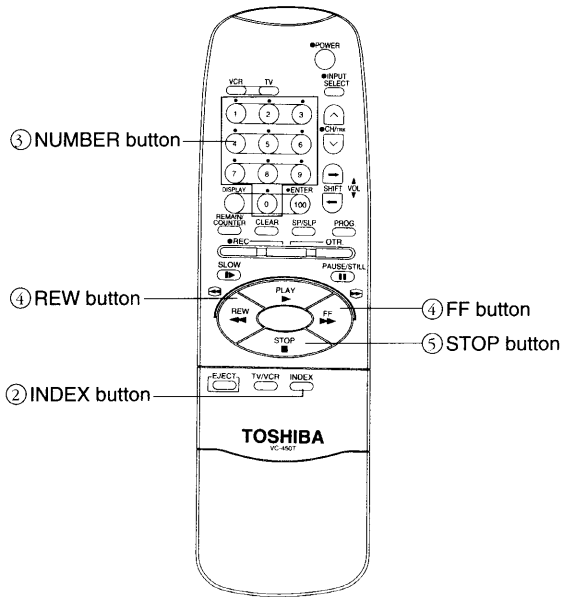

• Enter skip search from the stop or playback mode.

- ① Load the tape with index signals, then play back or stop it depending on preference.
- ② Press the *INDEX* button.

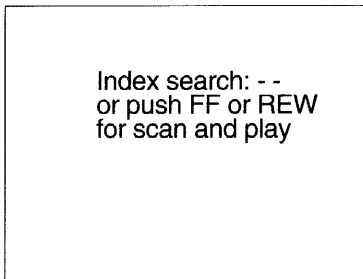

- ③ Press the *NUMBER* buttons to specify the index signal within 9 seconds. The index signal number is displayed on the screen.

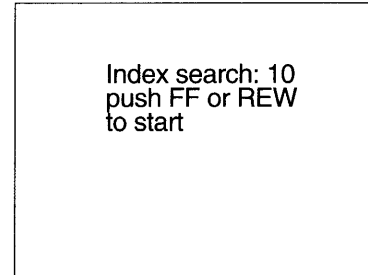

- ④ Within 9 seconds, press the *FF* button, if the desired index signal is in the program ahead, or the *REW* button if it is in the program behind.

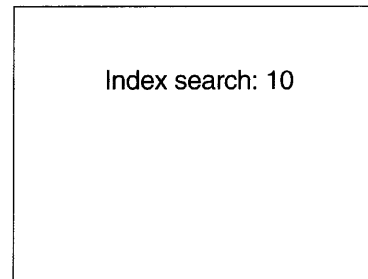

When the tape comes to the specified index signal it is played back automatically.

- ⑤ Press the *STOP* button to stop playback.

Numbering the index signals

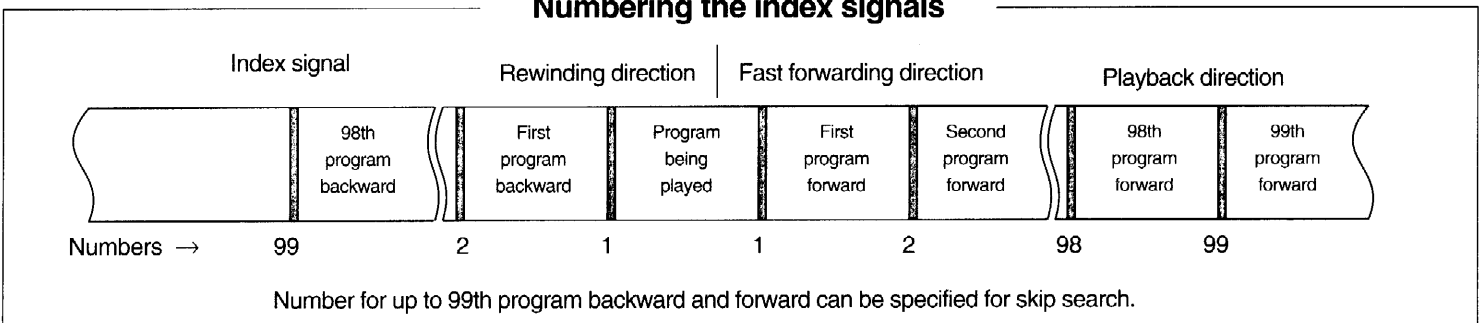

Notes:

- The counter read for numbers reduces by one each time an index signal is skipped.

SPECIALIZED OPERATIONS (continued)

Remaining Tape Display Function

This function displays the remaining time on the tape and may help you to plan ahead. This function is activated from the PLAY, REC, FF or REW mode.

- ① Load cassette into the cassette compartment. The VCR is turned on automatically.
- ② On the remote control, press the PROG button. The MENU will appear on the TV screen.
- ③ On the remote control, press the 2 button. This SETUP will appear on the TV screen.

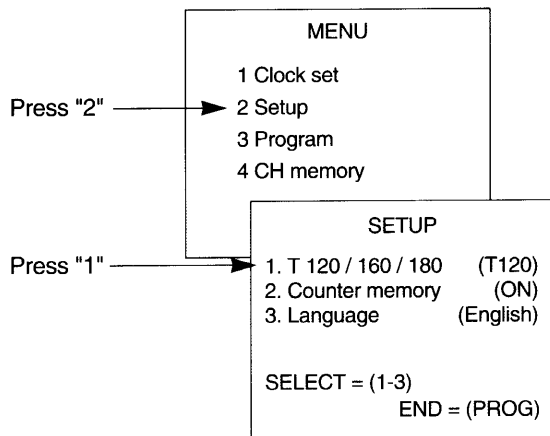

T-180: When using tape type T-180

T-160: When using tape type T-160

T-120: When using tape type T-120 or shorter

To enter T-180, T-160 or T-120, press the "1" button cyclically.

- ④ Press the *PROG* button twice to resume the normal screen.
- ⑤ Press the *DISPLAY* button once to display the normal displays on the TV screen.
- ⑥ Press the *DISPLAY* button again (while the normal display still appears on the TV screen) to display only the time counter on the TV screen. The time counter will remain on the TV screen.

- ⑦ Press the *PLAY* button or the *REC* button.
- ⑧ Press the *REMAIN/COUNTER* button. The VCR starts to calculate the remaining time on the tape. Tape runs for a while during calculation.

The counter enters into the calculation mode from the time counter display mode.

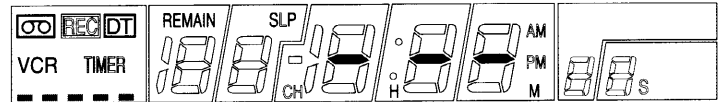

- ⑨ The calculation is completed within 1 minute at the most. The remaining time on the tape is indicated. (The example shows the remaining time is 1 hour 30 minutes.)

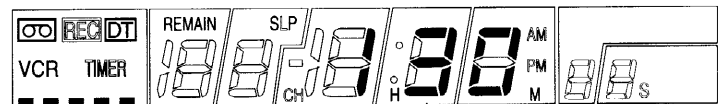
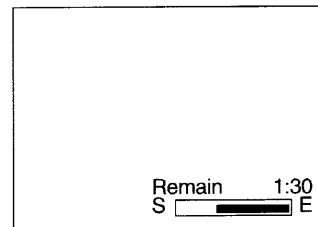

Remaining Time

Press the *REMAIN/COUNTER* button again and the counter changes from displaying the remaining time on the tape to the counter.

Notes:

- The remaining time on the tape is indicated when the *REMAIN/COUNTER* button is pressed. When the tape is removed, the counter returns to indicate the elapsed time.
- The remaining time displayed is approximate time.
- During recording, the remaining time is calculated based on the recording mode, SP or SLP, which is selected by the *SP/SLP* button.
- During playback, the remaining time is calculated based on the playback mode (SP/SLP speed).
- The remaining time can be displayed during FF/REW.

SPECIALIZED OPERATIONS (continued)

Copying VCR Recording Function

You can dub this tape for editing by connecting this VCR to another VCR.

Using this VCR for playback (see p. 25-27)

- ① Recording VCR: Press the *REC* button, then the *PAUSE/STILL* button to enter the recording pause mode.
- ② Playback VCR: Press the *PLAY* button to activate play.
- ③ Recording VCR: Press *PAUSE/STILL* button, then cancel the pause mode to activate recording.
- ④ Both VCRs: To terminate recording, press the *STOP* button on the VCRs. Copying is completed.

Using this VCR for recording (see p. 36)

- ① Recording VCR: Press the *REC* button, then the *PAUSE/STILL* button to enter the pause mode.
- ② Playing VCR: Press the play button to activate play.
- ③ Recording VCR: Press the *PAUSE/STILL* button again to cancel the pause mode to start recording.
- ④ Both VCRs: To terminate recording, press the stop button on both VCRs. Copying is completed.

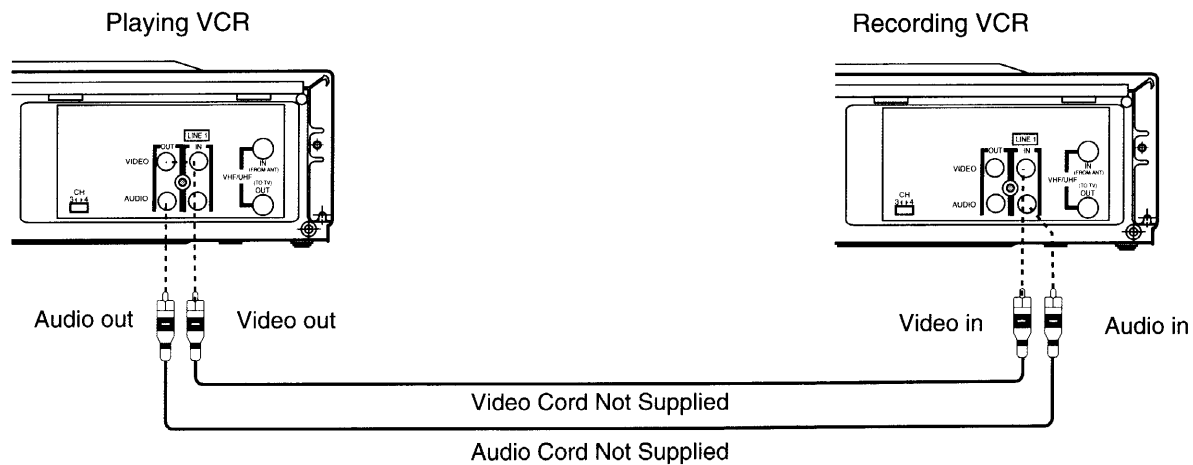

WARNING: Tapes can only be copied and used in accordance with applicable copyright laws. If the tape is covered by a copyright, it is illegal to copy it and/or charge an entrance fee to see it.

Note:

- In general, picture quality deteriorates somewhat in the dubbed tape. It is best to use the SP mode.

TROUBLE CHECKS

Sometimes problems can be easily solved by checking a few basic things. Check below before you call for help or take your VCR to an Authorized TOSHIBA VCR Service center.

It could save you time and money. If service should be necessary, Authorized TOSHIBA VCR Service centers are trained and equipped to furnish it.

Trouble	Checks and Adjustments
No Power	<ul style="list-style-type: none"> • Check to see if the VCR is plugged into an operating outlet.
VCR Does Not Respond to Remote Control	<ul style="list-style-type: none"> • Weak battery in remote control. • Remote control not aimed at the VCR or there is an obstruction between them. • Press the VCR button on the remote control for changing to the VCR mode.
Remote No Longer Controls a TOSHIBA TV	<ul style="list-style-type: none"> • Remote accidentally programmed for different brand of TV. Press TV and number buttons at the same time on the remote control to re-program. <i>Details are on page 21-22.</i>
Remote No Longer Controls a Compatible TV(Other Than TOSHIBA)	<ul style="list-style-type: none"> • Remote control may need to be re-programmed after batteries are changed. <i>See page 21-22.</i> • Check batteries in remote control.
Poor or No Picture for Normal TV Viewing	<ul style="list-style-type: none"> • VCR indicator is on. Press the TV/VCR button to turn it off. <i>See page 12</i> • TV monitor/receiver set to "video input". Switch TV to an active channel. • Carefully check antenna connections.
Snowy or No Picture During Playback	<ul style="list-style-type: none"> • Press one of the TRACKING buttons on the remote control to adjust tracking. <i>See page 26</i> • VCR indicator not on. Press TV/VCR button to turn it on. <i>See page 12</i> • Make sure the TV channel selector matches the channel you have selected with the CH3/CH4 switch on the back of the VCR (3 or 4). <i>See page 10</i> • Make sure the TV is fine tuned. • Check the video cable connections between the VCR and TV monitor/receiver. • Make sure the TV monitor/receiver is set to the "video input" channel. • Try another tape. • Dirty tape has left deposits on VCR's heads. <i>See page 24 for head cleaning.</i> • Some snow/streaks are normal during search, slow motion and stop-action playback.
Streaks in Picture During Normal Playback	<ul style="list-style-type: none"> • Press one of the TRACKING buttons on the remote control to move streaks up or down and out of the picture. • Tape stretched (poor quality or worn out). <i>See page 26</i>
Will Not Record or Play	<ul style="list-style-type: none"> • No cassette in VCR. • Eject and re-insert cassette. • Broken tape-try another cassette.
Will Not Record	<ul style="list-style-type: none"> • VCR is in pause mode. Press the PAUSE/STILL button. • Record-protect (safety) tab removed from cassette. <i>See page 24</i> • Make sure "L1(L2)" indicator is turned off in VCR's display panel for normal recording from the VCR's tuner. Press the INPUT SELECT button to turn off "L1(L2)" indicator.
Timer Recording Not Made	<ul style="list-style-type: none"> • Program entered incorrectly (wrong channel or times). • Power interruption. (Clock on the VCR's front panel will show "- : - -".) <i>See page 14(set the clock)</i> • Clock was not set accurately (check AM/PM). • Program exceeded tape's length or tape was not rewound beforehand. • VCR was not turned off at the time recording was to start. • No tape in VCR or cassette's record-protect (safety) tab broken off. <i>See page 24</i>
Tape Stops Before Complete Rewind	<ul style="list-style-type: none"> • Press the REW button again. Tape rewinds only to "0:00:00M" ("0:00:00" in VCR's display panel) when counter memory is turned on. <i>Details are on page 27.</i>
Rewind Does Not Operate	<ul style="list-style-type: none"> • Tape already rewound.
Clock Shows Incorrect Time or Date	<ul style="list-style-type: none"> • Power interruption. (Clock on the front panel will show "- : - -".) <i>See page 14. (set the clock)</i> • Clock was not set accurately (check AM and PM). • Clock display shows recording time remaining for OTR recording.
VCR Makes Noise When Stopped	<ul style="list-style-type: none"> • VCR is removing tape from heads. This is normal. The cylinder head inside the VCR will continue to rotate for about 5 minutes after you put the VCR in the stop mode.
Will Not Auto Program Active Channels Correctly	<ul style="list-style-type: none"> • CH MEMORY is not set correctly. <i>See page 13</i>
Can Not Select Channels Over 69	<ul style="list-style-type: none"> • Channels over 69 can only be selected if available from your cable-TV system. <i>See page 13</i>
Tape Plays Back in Slow Motion	<ul style="list-style-type: none"> • Press the PLAY button for normal playback..
Poor Picture for Cable TV Viewing	<ul style="list-style-type: none"> • Change the channel on the VCR, then return the channel to 3/4. <i>See page 10</i>

Cleaning the VCR

Dust exposed surfaces as required, using a soft cloth or the dusting attachment of your vacuum cleaner. Occasionally use the vacuum cleaner to remove dust from the ventilation holes on the top, back, sides and bottom of the cabinet.

Some of the plastic surfaces are easily scratched, and they can be marred by alcohol and various solvents. Avoid excessive use of oil-based furniture polishes since the materials used in the cabinet are non-porous and the residue will accumulate more dust.

Design Specifications

Format:	VHS
Record/Playback System:	Video : 2-Head record/playback system Audio: Mono record/playback system
Video Signal System:	EIA standard: NTSC color
Antenna:	75-ohm external VHF/UHF combined antenna terminal
Tuner:	USA: 181 channels (125 cable channels) CANADA: 178 channels (122 cable channels)
Type:	Auto-programming frequency synthesis
Power Requirement:	120AC, 60Hz
Power Consumption:	17 watts
Dimension:	93.5mm high (3.7 inches) 380mm wide (15.2 inches) 326.5mm deep (12.9 inches)
Weight:	4.0Kg (9.0lbs)
Storage Temperature Range:	-22° F to + 149 ° F
Operating Temperature Range :	+41° F to + 104 ° F

Specifications and features are subject to change without notice.

LIMITED WARRANTY

TOSHIBA VIDEO CASSETTE RECORDER

Toshiba America Consumer Products, Inc. ("TACP") and Toshiba Hawaii Inc. ("THI") make the following limited warranties. These limited warranties extended to the original consumer purchaser or any person receiving this set as a gift from the original consumer purchaser and to no other purchaser or transferee.

Limited Ninety (90) Day Warranty

TACP and THI warrant this product against defects in materials or workmanship for a period of ninety (90) days after the date of original retail purchase. During this period, TACP and THI will repair a defective product or part, without charge to you. You must deliver the entire product to a TACP/THI Service Center. You pay for all transportation and insurance charges for the set to and from the Service Center.

Limited One (1) Year Warranty

TACP and THI further warrant the parts in this product against defects in materials or workmanship for a period of one year after the date of original retail purchase. During this period, TACP and THI will replace a defective part without charge to you, except that if a defective part is replaced after ninety (90) days from the date of the original retail purchase you pay labor charges involved in the replacement. You must also deliver the entire product to one of the TACP/THI Service Centers. You pay for all transportation and insurance charges for the set to and from the Service Center.

Owner's Manual and Registration Card

You should read the owner's manual thoroughly before operating this product. You should also insure that your name and address are on file as owners of a TACP/THI product by completing and mailing the enclosed registration card within ten days after you, or the person who has given you this product as a gift, purchased this product.

Step-By-Step Procedures – How to Obtain Warranty Service

IN THE CONTINENTAL UNITED STATES...

Should your unit require service or parts, CALL



HAWAII

Toshiba Hawaii Inc. Service Department
327 Kamakee Street Honolulu, HI 96814
Phone Number:
(808) 521-5377

IN THE EVENT A PROBLEM SHOULD DEVELOP WITH YOUR PRODUCT, PLEASE PROCEED AS FOLLOWS:

- (1) Refer to the troubleshooting guide in your owner's manual. This check list may solve your problem.
- (2) Contact one of the TACP/THI Service Centers listed below for warranty service or call the TACP toll free number 1-800-631-3811 within thirty (30) days after you find a defective product or part.
- (3) Arrange for the delivery of the product to the Authorized TACP/THI Service Center. Products shipped to the Service Center must be insured and safely and securely

packed, preferably in the original shipping carton, and a letter explaining the defect and also a copy of the bill of sale or other proof of purchase must be enclosed. All transportation and insurance charges must be prepaid by you. (See Packing and Shipping instructions on TOSHIBA SERVICE PROCEDURE).

- (4) If you have any question about service, please contact one of the following TACP/THI Service Centers:

EAST

82 Totowa Road
Wayne, NJ 07470
Phone Number:
(201) 628-8000

SOUTHEAST

490 Armour Circle, N.E.
Atlanta, GA 30324
Phone Number:
(404) 872-6955

MIDWEST

1010 Johnson Drive
Buffalo Grove, IL
60089
Phone Number:
(708) 541-9400

SOUTHWEST

1421 champion Drive
Suite 304
Carrollton, TX 75006
Phone Number:
(214) 243-1367

WEST

5490 E. Francis Street
Ontario, CA 91761
Phone Number:
(909) 988-5303

IMPORTANT: PACKING AND SHIPPING INSTRUCTIONS

When you send the product to a service center, you must use the original carton box and packing material, then insert the original carton box containing the unit into another carton, using more packing material.

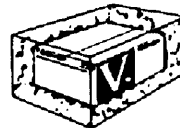

ALL WARRANTIES IMPLIED BY STATE LAW, INCLUDING THE IMPLIED WARRANTIES OF MERCHANTABILITY AND FITNESS FOR A PARTICULAR PURPOSE, ARE EXPRESSLY LIMITED TO THE DURATION OF THE LIMITED WARRANTIES SET FORTH ABOVE. Some states do not allow limitations on how long an implied warranty lasts, so the above limitation may not apply to you. **WITH THE EXCEPTION OF ANY WARRANTIES IMPLIED BY STATE LAW AS HEREBY LIMITED, THE FOREGOING EXPRESS WARRANTY IS EXCLUSIVE AND IN LIEU OF ALL OTHER WARRANTIES, GUARANTEES, AGREEMENTS AND SIMILAR OBLIGATIONS OF MANUFACTURER OR SELLER WITH RESPECT TO THE REPAIR OR REPLACEMENT OF ANY PRODUCT OR PARTS.**

IN THE EVENT SHALL TACP OR THI BE LIABLE FOR CONSEQUENTIAL OR INCIDENTAL DAMAGES. Some states do not allow the exclusion or limitation of incidental or consequential damages so the above limitation may not apply to you.

No person, agent, distributor, dealer, service station or company is authorized to change, modify or extend the terms of these warranties in any manner whatsoever. The time within which an action must be commenced to enforce any obligation of TACP and THI arising under this warranty or under any statute, or law of the United States or any state thereof, is hereby limited to one year from the date you discover or should have discovered, the defect. This limitation does not apply to implied warranties arising under state law. Some states do not permit limitation of the time within which you may bring an action beyond the limits provided by state law so the above provision may not apply to you. This warranty gives you specific legal rights and you may also have other rights which vary from state to state.

TOSHIBA AMERICA CONSUMER PRODUCTS, INC.

Printed in Korea



TOSHIBA
...In Touch with Tomorrow