

**TOSHIBA**

**SERVICE HANDBOOK**  
**FACSIMILE (FOR DP1600/2000/2500)**

**GD-1060**



Click the Navigation Pane button to open the overview area and display bookmarks and thumbnails palettes.

**Bookmarks**

Click the Bookmarks to open the Contents and display Bookmarks created for the document. Click a bookmark's name to go to the Page marked by that bookmark.

**Thumbnails**

Click the Thumbnails to open the overview area and display thumbnail images of each document page. Click a thumbnail to go to the Page marked by that thumbnail.

Copyright TOSHIBA TEC CORPORATION 2001  
ALL RIGHTS RESERVED



# GENERAL PRECAUTIONS REGARDING THE INSTALLATION AND SERVICE FOR DP1600/2000/2500 AND GD-1060

The installation and service should be done by a qualified service technician.

## 1. Transportation

- When transporting/installing the copier, employ two persons and be sure to use the positions as indicated below.

The copier is fairly heavy and weighs approximately 50 kg (110 lb), therefore pay full attention when handling it.

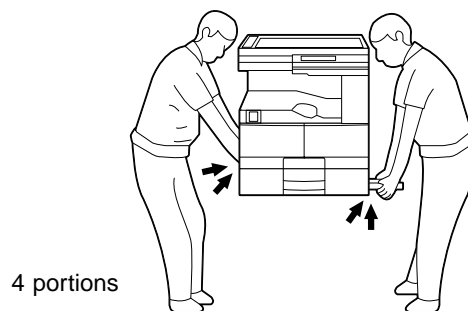

## 2. Installation

- Be sure to use a dedicated outlet with AC 115 or 120V/15A (220V, 230V, 240V/10A) or more for its power source.
- The copier must be grounded for safety.  
Never ground it to a gas pipe or a water pipe.
- Select a suitable place for installation.  
Avoid excessive heat, high humidity, dust, vibration and direct sunlight.
- Also provide proper ventilation as the copier emits a slight amount of ozone.
- To insure adequate working space for the copying operation, keep a minimum clearance of 80 cm (32") on the left, 80 cm (32") on the right and 10 cm (4") in the rear.
- After having installed the copier, be sure to push the carrying handles into the copier.

## 3. Service of Machines

- Basically, be sure to turn the main switch off and unplug the power cord during service.
- Be sure not to touch high-temperature sections such as the exposure lamp, the fuser unit, the damp heater and their periphery.
- Be sure not to touch high-voltage sections such as the chargers and the high-voltage transformer.
- Be sure not to touch rotating/operating sections such as gears, belts, pulleys, fans, etc.
- When servicing the machines with the main switch turned on, be sure not to touch live sections and rotating/operating sections. Avoid exposure to laser radiation.
- Use suitable measuring instruments and tools.

- Avoid exposure to laser radiation during servicing.
  - Avoid direct exposure to beam.
  - Do not insert tools, parts, etc. that are reflective into the path of the laser beam.
  - Remove all watches, rings, bracelets, etc. that are reflective.

#### 4. Main Service Parts for Safety

- The breaker, door switch, fuse, thermostat, thermofuse, thermistor, etc. are particularly important for safety. Be sure to handle/install them properly.

#### 5. Cautionary Labels

- During servicing, be sure to check the rating plate and the cautionary labels such as “Unplug the power cord during service”, “Hot area”, “Laser warning label” etc. to see if there is any dirt on their surface and whether they are properly stuck to the copier.

#### 6. Disposition of Consumable Parts/Packing Materials

- Regarding the recovery and disposal of the copier, supplies, consumable parts and packing materials, it is recommended to follow the relevant local regulations or rules.

#### 7. When parts are disassembled, reassembly is basically the reverse of disassembly unless otherwise noted in this manual or other related documents. Be careful not to reassemble small parts such as screws, washers, pins, E-rings, toothed washers in the wrong places.

#### 8. Basically, the machine should not be operated with any parts removed or disassembled.

#### 9. Precautions Against Static Electricity

- The PC board must be stored in an anti-electrostatic bag and handled carefully using a wristband, because the ICs on it may become damaged due to static electricity.

**Caution:** Before using the wrist band, pull out the power cord plug of the copier and make sure that there is no uninsulated charged objects in the vicinity.

**Caution:** Dispose of used batteries and RAM-ICs including lithium batteries according to the manufacturer's instructions.

**Attention:** Se débarrasser de batteries et RAM-ICs usés y compris les batteries en lithium selon les instructions du fabricant.

**Vorsicht:** Entsorgung des gebrauchten Batterien und RAM-ICs (inklusive der Lithium-Batterie) nach Angaben des Herstellers.

# 1. ADJUSTMENT ITEMS

## 1.1 Error Codes

The operator and service technician can check an error condition by using the error on the LCD and the communication error code and status code printed on the transmission/reception journal.

### 1.1.1 Transmission/reception journal

The transmission/reception journal is shown below. Refer to the error code list and the status code list on the following pages.

TRANSMISSION JOURNAL													
		PAGE		: 001									
		TIME		: NOV-15-00 04:09PM									
		TEL NUMBER		: 12345678901234567890									
		E-MAIL		: ABCDEFGHIJKLMNOPQRSTUVWXYZ12345678901234									
		NAME		: ABCDEFGHIJKLMNOPQRSTUVWXYZABCDEFGHIJKLMN									
		SCAN COUNT		: 67 (00000043)									
		PRINT COUNT		: 97 (00000061)									
		DRUM COUNT		: 970 (000003CA)									
NBR	FILENBR	DATE TIME	DURATION	PGS	TO	DEPT	ACCOUNT	MODE	STATUS				
001	001	NOV-15 12:00AM	00/41	001	12345678901234567890	D 01	9999	G3 330 P	OK	30			
002	010	NOV-16 11:10AM	03/47	006	123456			EC 503 P	OK				
003	011	NOV-18 01:14PM	00/24	000	0559891024	D 08		EX 512 R	NG	DO			
004				012	<>03123456	D 20	2000	HS 111 B	OK				
					001020			EC 602 SB	NG				

Status code ————  
 Communication error code ————

\*The reception journal has the same format.

### 1.1.2 Error code list

If an error has occurred during communication, an error code is indicated in the "STATUS" column of the transmission/reception journal.

Take an appropriate action, referring to the following list.

Code		Cause	Remedy
Maintenance	User		
10	10	There was no recording paper or the paper cassette was not installed during the reception.	Supply recording paper and insert the paper cassette firmly.
11	11	A recording paper jam occurred during the reception.	Remove the jammed recording paper.
12	12	A document jam occurred.	Remove the jammed original, then try the transmission again.
13	13	During the transmission, any cover was opened and the transmission stopped.	Attempt the transmission again.
20	20	A power failure occurred during the transmission or reception, and the transmission/reception original data was lost.	Attempt the transmission or reception again.
30	30	The [CLEAR/STOP] key was pressed during the communication, and the communication was stopped.	Attempt the transmission or reception again.
32	32	The set number of original pages did not match the actual pages transmitted.	Check the actual original count.
33	33	The polling password did not match, or no polling document existed.	Check the polling password or check if there is a polling original on the remote party's side, and attempt the polling reception again.
42	42	During a memory transmission or a memory reception, the machine ran out of image memory. The machine's image memory was exhausted.	Divide the originals into several transmissions for a memory transmission. For a memory reception, remove the cause of the error, then ask the remote party to transmit the original again.

Code		Cause	Remedy
Maintenance	User		
50	50	Dialing and redialing was attempted as many as the specified count but the line was busy.	Confirm the phone numbers of the remote party.
53	53	The password did not match in a Relay or Mailbox transmission, and the transmission ended in failure.	Confirm that both parties are using the same system password and the both units are compatible. Then, ask the remote party to transmit again.
B0	80	DIS (GI) could not detected.	This may happen in some cases of bad line condition. Attempt the transmission again.
B1	82	DIS/NSF that cannot be handled by the sender is received. The receiver received NSS/DCS other than those declared by DIS/NSF.	This may happen in some cases of bad line condition. Attempt the transmission again or ask the remote party to attempt the transmission again.
B2	82	DCN is received.	This may happen in some cases of bad line condition. Attempt the transmission again.
B3	80	DCS/DTC was not detected.	This may happen in some cases of bad line condition. Attempt the transmission again.
B4	82	The sender performed fall-back but the transmission was not enabled. The receiver was not detect TCF or detected DCN after sending FTT.	This may happen in some cases of bad line condition. Attempt the transmission again. Or ask the remote party to attempt the transmission again.
B5	80	CFR (FTT) was not detected.	This may happen in some cases of bad line condition. Attempt the transmission again.
C0	85	Image signal carrier was not detected.	This may happen in some cases of bad line condition. Ask the remote party to transmit again.
C1	83	High-speed signal was not detected on the receiving side.	This may happen in some cases of bad line condition. Ask the remote party to transmit again.

Code		Cause	Remedy
Maintenance	User		
C2	85	After detecting the image signal, carrier off was detected on the receiving side.	This may happen in some cases of bad line condition. Ask the remote party to transmit again.
C3	83	After detecting a high-speed signal, EOL was not detected on the receiving side.	This may happen in some cases of bad line condition. Ask the remote party to transmit again.
C4	83	The EOL timer has timed out.	This may happen in some cases of bad line condition. Ask the remote party to transmit again.
D0	80	Post response signal was not detected on the sending side. Post signal was not detected on the receiving side.	This may happen in some cases of bad line condition. Attempt the transmission again. Or ask the remote party to attempt the transmission again.
D1	82	DCN is received.	This may happen in some cases of bad line condition. Ask the remote party to transmit again.
D2	86	RTN/PIN/ERR is received on the sending side. RTN/PIN/ERR is received on the receiving side.	This may happen in some cases of bad line condition. Ask the remote party to transmit again.
E0	21	A printer error occurred during a reception, and the machine is shifted into memory reception mode. However, there was not enough residual memory.	Remove the cause of the printer error, then ask the remote party to transmit again.
E6	21	An error relating to the printer has occurred.	Confirm details of the error using the error code and correct the error. Then ask the remote party to transmit again.
F0	83	The communication ended because of a watchdog timer due to an overrun of the software.	Attempt the communication again. If the error occurs frequently, perform a memory clear (except user area.)
F1	83	The communication ended because of an overrun of the software due to hardware noises.	Attempt the communication again. If the error occurs frequently, perform a memory clear (except user area.)

### 1.1.3 Status code list

Using the 3-digit status code indicated in the “MODE” column of the transmission/reception journal, the communication mode of each job can be confirmed.

Each of the 3-digit of the status code has an individual meaning. These digits represent the following.

• **1st digit**

Mode	TX Speed (bps)
0	2400
1	4800
2	7200
3	9600
4	12000
5	14400
6	V.34

• **2nd digit**

Mode	Line density
0	8 x 3.85
1	8 x 7.7
2	8 x 15.4
3	—
4	16 x 15.4
8	300 dpi

• **3rd digit**

Mode	Encoding
0	MH
1	MR
2	MMR
3	JBIG

**[Example of indicating a status code]**

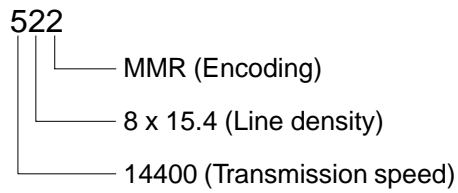

For the combination of 14400 bps, 8 x 15.4 and MMR, as shown above, a status of “522” is indicate.



#### 1.1.4 Error message

When an error of facsimile communication occurs, an error message is indicated on the LCD.

The following show error messages and their appropriate actions.

Display	Cause	Remedy
LINE BUSY	The destination is being used so that transmission cannot be performed.	Wait for a while, then attempt transmission again.
COMMUNICATION ERROR	A communication protocol error has occurred.	This may happen in some cases of bad line condition. Attempt transmission again. Or ask the remote party to attempt the transmission again.
MEMORY OVERFLOW	The image memory has overflowed.	Press the [CLEAR/STOP] key to clear the message. In memory transmission mode, transmit the original divided into several transmit sequences, or transmit the original again from the beginning when enough memory is available. In memory reception operation, correct the condition which lead to the memory reception. Then receive the original again.

## 1.2 Self-diagnosis Modes

The fax self-diagnosis mode expands the PPC self-diagnosis function. This section describes the self-diagnosis functions that are expanded by attaching the fax kit (GD-1060).

Mode	How to enter	Definition	How to clear
Country code	Turn the power on while pressing the 0 and 2 keys.	Selects the country code.	*1
Adjust mode	Turn the power on while pressing the 0 and 5 keys.	Finely adjusts copy image quality. Confirmation printing enabled by pressing the INTERRUPT key.	Turn the power off.
System mode	Turn the power on while pressing the 0 and 8 keys.	Performs setups for the system, maintenance, operations, printer, scanner, etc.	Turn the power off.
Scanner parking mode	Turn the power on while pressing the 0 and 9 keys.	Fixes the scanner carriage in place when transporting the copier.	Turn the power off.
RAM clear	Turn the power on while pressing the 1, 3, and * keys.	Clears values excluding the ones set in 08-446/447 and in the Adjust mode (05).	*2
Service mode *3	Press the PROGRAM key while READY is indicated, and then press the *, #, *, then * keys.	Performs setups for FUNCTION TEST and MAINTENANCE, and prints the Service List.	Press the PROGRAM key, and then press the *, #, *, then * keys. Or turn the power off. Or press the COPY key, press the MAIN MENU key.
FUNCTION TEST	After entering the service mode, select it on the screen. This mode is selected by turning the power on while pressing the 1 and 3 keys.	Conducts OPE. PANEL TEST, PRINT TEST, MODEM TEST, etc.	
MAINTENANCE	After entering Service Mode, select it on the screen.	Performs setups for Memory Clear, facsimile function, etc.	
Service list	After entering Service Mode, select it on the screen.	Prints PROTOCOL TRACE, Total Error, FUNCTION LIST, etc.	

\*1: After inputting the country code, the copier automatically enters the warm up mode.

\*2: After the RAM clear, the machine automatically enters the warm up mode.

\*3: In the SERVICE MODE, each function of the FUNCTION TEST, MAINTENANCE, or SERVICE LIST in each test item of the TEST MODE (displayed by pressing the PROGRAM key), are added. When the copier enters this mode, these functions are available.

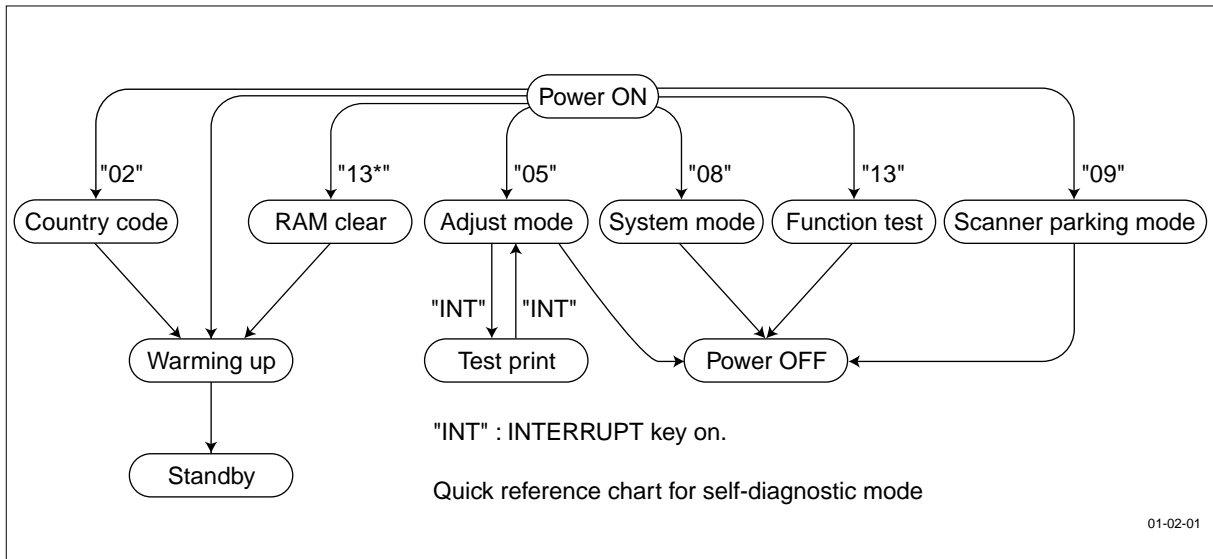

- Note:** Power ON Turn on the power switch.  
 Power OFF Turn on the power switch.  
 INT Press the INTERRUPT key.  
 C/S Press the CLEAR/STOP key.

**Menu map**

The menu below can be selected by pressing the program key. (However, the menu in the broken-dotted box are displayed only when the copier enters the SERVICE MODE.)

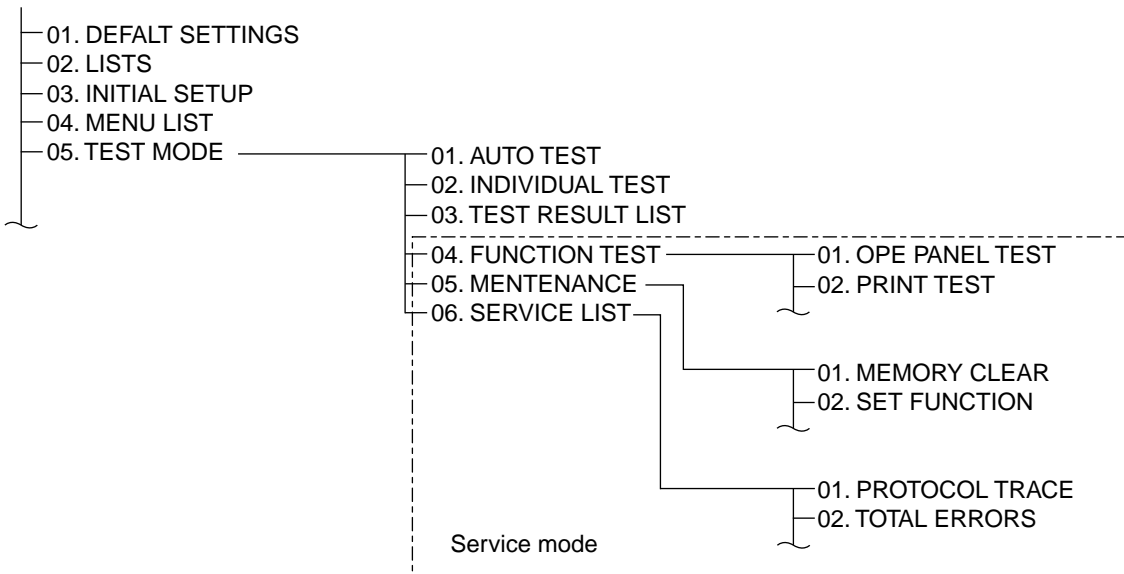

01-02-02

### 1.2.1 Adjust mode (05)

<Key used in operation>

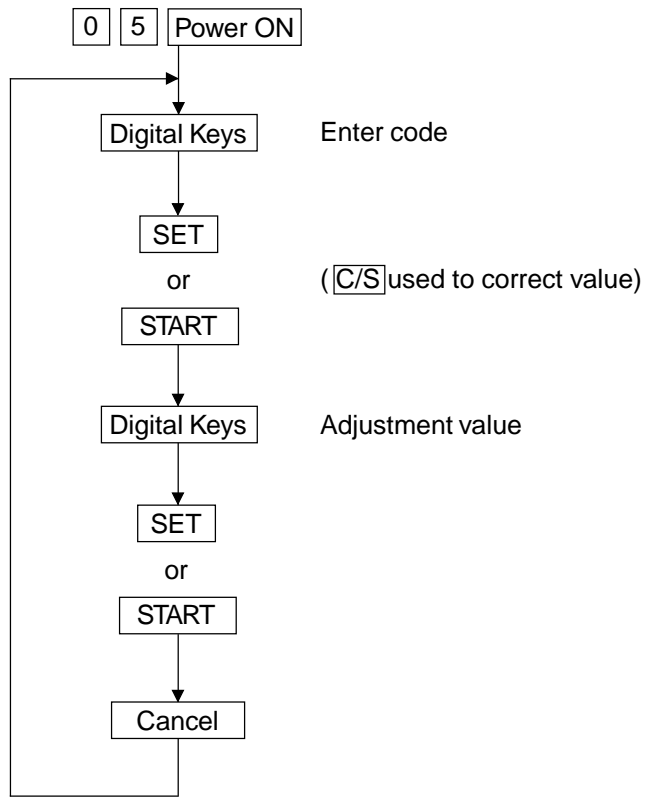

<Display messages>

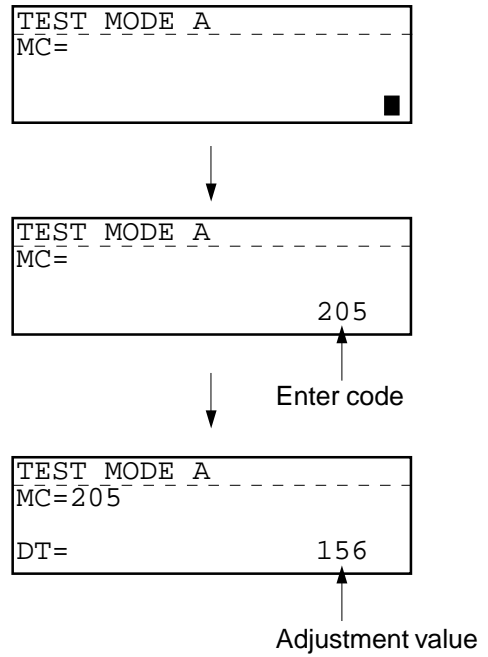

## ADJUST MODE (05) ITEMS

### Printer adjustment

Code	Factor	Adjustment item	Default value	Acceptable value
403	Printer system	Polygon motor speed fine adjustment 16 x 15.4 0.126%/step	128	98 - 158
404	Printer system	Polygon motor speed fine adjustment 15.4 x 16 0.121%/step	128	98 - 158
413	Printer system	Laser start position 16 x 15.4 Cassette 1	128	0 - 255
414	Printer system	Laser start position 15.4 x 16 Cassette 1	128	0 - 255

### Scanned image parameter for FAX

Code	Factor	Adjustment item	Image quality mode	Default value	Acceptable value *1
700	Density	Simple binarizing threshold adjustment Center value	Text	121	0 - 255 L ← V → D
701	Density	Simple binarizing threshold adjustment Light step value	Text	18	0 - 255 V → L
702	Density	Simple binarizing threshold adjustment Dark step value	Text	16	0 - 255 V → D
710	Density	Manual density fine adjustment Center value	Photo	145	0 - 255 L ← V → D
714	Density	Manual density fine adjustment Center value	Text/Photo	140	0 - 255 L ← V → D
715	Density	Manual density fine adjustment Light step value	Photo	18	0 - 255 V → L
719	Density	Manual density fine adjustment Light step value	Text/Photo	16	0 - 255 V → L
720	Density	Manual density fine adjustment Dark step value	Photo	20	0 - 255 V → D
724	Density	Manual density fine adjustment Dark step value	Text/Photo	17	0 - 255 V → D
725	Density	Auto density fine adjustment	Photo	145	0 - 255 L ← V → D
729	Density	Auto density fine adjustment	Text/Photo	138	0 - 255 L ← V → D

\*1: L = Light, V = Value, D = Dark

## 1.2.2 Function table

### (1) FUNC 0-39

The settings here cover all the functions of this facsimile unit that can be adjusted by a service technician. The functions consist of 40 tables in with each table having 8 bits (0 ~ 7).

#### • FUNC 0

Bit	Contents	Link with User Function Setting
7	Terminal ID entry for user mode: 0: Disable 1: Enable	—
6	Undefined	—
5	Program Continuous Polling open to users: 0: Disable 1: Enable	—
4	Exchange Type Setting for User Mode: 0: Disable 1: Enable	—
3	Dial Type Setting for User Mode: 0: Disable 1: Enable	—
2	Undefined	—
1	Undefined	—
0	Undefined	—

<Remarks>

FUNC 0 Bit 7:

This bit determines whether or not the Terminal ID programming operation is available to users.

FUNC 0 Bit 5:

This bit determines whether or not the Program continuous polling operation is made available to users.

**Note:** When “Prohibits setting by users” is selected, “PROG. CONT. POLLING” is not displayed in polling programming.

FUNC 0 Bit 4:

This bit determines whether or not selection between PSTN and PABX is made available to users.

FUNC 0 Bit 3:

This bit determine whether or not selection between DP and MF is mode available to users.

**Note:** When “Disable” is selected, the PSTN/PABX selection screen is not displayed in the dial type setup menu.

• FUNC 1

Bit	Contents	Link with User Function Setting
7 6 5 4	Undefined	—
3	Download execute condition (RDC): 0: No job in memory 1: Anytime	Yes
2	Remote access user setting: 0: Disable 1: Enable	Yes
1 0	EOL (End of Line) Timer Value: 00: 5sec. 01: 6sec. 10: Undefined 11: 13sec.	—

<Remarks>

FUNC 1 Bit 3:

Upgrading (changing) the firmware normally clears all the Pending Jobs remained in the memory.  
Refer to page 1-105.

FUNC 1 Bit 2:

Set whether or not the remote access user setting.  
Refer to page 1-104.

FUNC 1 Bits 1 and 0:

These bits indicate the setting of the EOL (End of Line) check timer in high-speed image data.

**Note:** EOL is the code that is put between lines. If the next EOL is not detected within the time specified in this setting, the line is disconnect due to communication error.

• FUNC 2

Bit	Contents	Link with User Function Setting
7 6	Undefined	—
5 4	Frequency Detection Range to recognize as CI: 00: 12 Hz to 80 Hz 01: 16 Hz to 55 Hz 10: 20 Hz to 55 Hz 11: 22 Hz to 55 Hz	—
3	Undefined	—
2	Undefined	—
1 0	Undefined	—

<Remarks>

FUNC 2 Bits 5 and 4:

These bits program the detection range for frequency to be recognized as CI.



• **FUNC 3**

Bit	Contents	Link with User Function Setting
7	Handing of Negative Answer (RTN/PIN): 0: Regards it to be abnormal. 1: Regards it to be normal.	—
6	Undefined	—
5	Undefined	—
4	Short Protocol: 0: Disable 1: Enable	—
3	Undefined	—
2	Undefined	—
1	Undefined	—
0	Undefined	—

<Remarks>

FUNC 3 Bit 7:

This bit programs whether or not a received RTN is handled as abnormal (NG).

FUNC 3 Bit 4:

This bit determines whether or not the Toshiba short protocol is enabled or disabled.

• FUNC 4

Bit	Contents	Link with User Function Setting
7 6 5 4	Transmission attenuator value for V.17 modem: 0000 to 1111 ... counts up for every -1dB 0000: 0 dB . . . 1111: -15 dB	—
3 2 1 0	Undefined	—

<Remarks>

FUNC 4 Bits 7 to 4:

The bit settings allow the user to program the modem transmission attenuation level. The smaller the set value, the higher the transmission level becomes. If errors occur frequently or training is not sent, the transmission level should be changed, as a rule.

• FUNC 5

Bit	Contents	Link with User Function Setting
7 6	Cable Equalizer: 00: 0dB 01: -4dB 10: -8dB 11: -12dB	—
5	Echo Protect Tone to V.29: 0: Not added 1: Added	—
4	Echo protection delay (300 bps): 0: No delay 1: Delay (500 ms)	—
3	Echo protection delay (High speed): 0: No delay 1: Delay (500 ms)	—
2	Undefined	—
1	Sending of CNG Signal at Manual Transmission: 0: Do not send 1: Send	—
0	Sending of CED Signal at Manual Reception: 0: Do not send 1: Send	—

<Remarks>

FUNC 5 Bits 7 and 6:

These bits program the equalizer value which has frequency characteristics. For long-distance communication, a larger equalizer value is recommended as a rule.

FUNC 5 Bit 5:

This bit selects whether or not the echo protect tone is added before the training for V.29 (9600 bps) communication. By adding the echo protect tone, the echo cancel circuit of the satellite line is started up to improve the line status.

FUNC 5 Bit 4:

This bit selects whether or not a delay (500 ms) is inserted before sending the signal at reversing transmission/reception change and the timing is shifted to avoid line echo.

When the echo preventing circuit or echo cancel circuit causes missing of the beginning of the signal, for example, in overseas communications where a delay may be larger, this bit should be set to 1 (on).

FUNC 5 Bit 3:

This bit selects whether or not a delay (500 ms) is inserted before the high-speed signal is sent to shift the timing. Explanation for bit 4 is applicable.

FUNC 5 Bit 1:

This bit selects whether or not the CNG signal is output in manual transmission (on-hook dialing/off-hook dialing). When the receiving terminal uses a switching device, CNG signal output is required (1=on).

FUNC 5 Bit 0:

This bit selects whether or not the CED signal is transmitted in manual reception.

• FUNC 6

Bit	Contents	Link with User Function Setting
7 6 5 4	Initial value of the communication speed designated by DIS/DCS signal: 0000: 2400 bps 0001: 14400 bps (V.17) 0010: Undefined 0011: Undefined 0100: 4800 bps 0101: 12000 bps (V.17) 0110: Undefined 0111: Undefined 1000: 9600 bps 1001: 9600 bps (V.17) 1011: Undefined 1100: 7200 bps 1101: 7200 bps (V.17) 1110: Undefined 1111: Undefined	—
3 2	Threshold of image error: 00: 5% 01: 10% 10: 15% 11: 25%	—
1	Monitor Type: 0: BT Monitor 1: Protocol Monitor	—
0	Undefined	—

<Remarks>

FUNC 6 Bits 7 to 4:

These bits set the modem speed. The speed should be programmed when the telephone line quality is poor.

FUNC 6 Bits 3 and 2:

These bits set a threshold value to judge image quality. To make the criteria stringent, 00 (5%) should be selected. When the threshold value is exceeded, RTN will be initiated.

FUNC 6 Bit 1:

This bit selects the monitor type when the line monitor function is turned on. When this bit is set to 0 (BEFORE TRANSMISSION MONITOR), monitoring stops on receiving DIS. When this bit is set to 1 (PROTOCOL MONITOR), monitoring is performed during communication, like forced line monitor.

• FUNC 7

Bit	Contents	Link with User Function Setting
7 6	CI-ON Determine Time: 00: 175 ms 01: 125 ms 10: 800 ms 11: 145 ms	—
5 4	CI-OFF Determine Time: 00: 500 ms 01: 350 ms 10: 175 ms 11: 90 ms	—
3	Undefined	—
2 1 0	Undefined	—

<Remarks>

FUNC 7 Bits 7 and 6:

These bits program call signal ON time. When CI cannot be received, the value should be changed.

FUNC 7 Bits 5 and 4:

These bits program call signal OFF time.

• FUNC 8

Bit	Contents	Link with User Function Setting
7	Long Original mode: 0: Disable 1: Enable	Yes
6	Page Re-transmission at receiving Negative Answer: 0: Not re-transmit 1: Transmit	—
5	Page-mismatch Display Indication: 0: Not displayed 1: Displayed	—
4	Undefined	—
3	Undefined	—
2	Undefined	—
1	Undefined	—
0	Undefined	—

<Remarks>

FUNC 8 Bit 7:

This bit determines whether or not Long original function is available.

FUNC 8 Bit 6:

This setting is performed to avoid double transmission due to memory retransmission. When this bit is set to 0 (off), the machine does not perform retransmission and proceeds to next page transmission. During retries, the machine starts transmission of the next page.

FUNC 8 Bit 5:

This setting performs error indications if the number of pages do not match.



• **FUNC 9**

Bit	Contents	Link with User Function Setting
7 6	Undefined	—
5 4 3	Undefined	—
2 1 0	Speaker volume for all error tone: 000: Level 0 (off) 001: Level 1 010: Level 2 011: Level 3 100: Level 4 101: Level 5 110: Level 6 111: Level 7 (maximum)	Yes

<Remarks>

FUNC 9 Bits 2 to 0:

Allows the user to adjust the volume level of the speaker when an error occurs.

• FUNC 10

Bit	Contents	Link with User Function Setting
7 6	Transmission Report after a Direct Document Transmission: 00: Do not print 01: Undefined 10: Always print 11: Print (re-sending of error pages is OK)	Yes
5 4 3	Transmission Report Output after Memory Transmission: 000: Not print 001: Undefined 010: Always output 011: Print (when completed due to communication error.) 100: Undefined 101: Undefined 110: Always print (with sent document) 111: Print (when completed due to communication error + with sent document)	Yes
2 1 0	Transmission Report Output after Multi-address Transmission: 000: Do not print 001: Do not print 010: Always print 011: Print (when completed due to communication error) 100: Undefined 101: Undefined 110: Always print (with sent document) 111: Print (when completed due to communication error + with sent document)	Yes

<Remarks>

FUNC 10 Bits 7 and 6:

Allows the use to choose how and when a transmission report is printed.

FUNC 10 Bits 5 to 3:

These bits program whether or not the memory transmission report is output. These bits also select output conditions. Allows the user to choose whether or not (and when) a transmission report is printed when transmission is through "memory."

FUNC 10 Bits 2 to 0:

These bits program whether or not the broadcast transmission report is printed and the conditions for printing.

• FUNC 11

Bit	Contents	Link with User Function Setting
7 6	Undefined	—
5	Midnight and Noon time setting: 0: 00:00 1: 12:00	—
4 3	Print report after a Multi-polling: 00: Do not print 01: Do not print 10: Always print 11: Print (when completed due to communication error.)	Yes
2 1 0	Undefined	—

<Remarks>

FUNC11 Bit 5 :

Determines how midnight and noon time is displayed.

FUNC 11 Bits 4 and 3:

These bits program whether or not the multi polling transmission report is printed or not and the conditions for printing.

• FUNC 12

Bit	Contents	Link with User Function Setting
7 6 5	Undefined	—
4 3 2	Undefined	—
1	Undefined	—
0	Report print at user cancel: 0: Do not print 1: Print	—

<Remarks>

FUNC 12 Bit 0:

Determines if transmission result report is printed if the user cancels the job.

• **FUNC 13**

Bit	Contents	Link with User Function Setting
7	Undefined	—
6	Mailbox Reception List (Local Input): 0: Do not print 1: Print	Yes
5	Mailbox Reception List (Remote Input): 0: Do not print 1: Print	Yes
4	Automatic print of Journal: 0: Do not print 1: Print	Yes
3 2	Recording contents when Journal is output manually: 00: Transmissions only 01: Receptions only 10, 11: Transmissions/Receptions	Yes
1	NG Handling on Journal Status: 0: Do not print 1: Print	—
0	Undefined	—

<Remarks>

**FUNC 13 Bit 6:**

It determines whether or not the reception list is printed when a mail box option is chosen at own terminal.

**FUNC 13 Bit 5:**

It determines whether or not the acceptance list is print when a “mail box” information is received.

**FUNC 13 Bit 4:**

Selection determines whether or not the journal is printed automatically.

**FUNC 13 Bits 3 and 2:**

These selections determine whether or not the journal is printed manually, and select items to be recorded (transmission, reception or transmission/reception).

**FUNC 13 Bit 1:**

Selections determine whether or not OK or NG (failed) is added as a communication result on the journal.

• FUNC 14

Bit	Contents	Link with User Function Setting
7 6 5 4	CI Signal Detect Count until Auto Receive: 0000 to 1111 ... counts up on every 1 time 0000: 1 time 0001: 1 time 0010: 2 times . . . 1111: 15 times	Yes
3 2 1	Speaker Volume of On-hook and Protocol Monitor: 000: Level 0 (off) 001: Level 1 010: Level 2 011: Level 3 100: Level 4 101: Level 5 110: Level 6 111: Level 7 (maximum)	Yes
0	Undefined	—

<Remarks>

FUNC 14 Bits 7 to 4:

Selections set the CI counter value until the machine enters automatic reception mode.

FUNC 14 Bits 3 to 1:

Selections set speaker volume for the on-hook status or protocol monitor.

• **FUNC 15**

Bit	Contents	Link with User Function Setting
7 6	Discard length of document paper: 00: No discard (0 mm) 01: Discard <b>13 mm</b> 10: Discard 17 mm 11: Discard 34 mm	—
5	Vertical reduction on recording paper: 0: Prohibited 1: Allowed	—
4	Undefined	—
3	Undefined	—
2	Discard setting of recording paper: 0: OFF 1: ON	Yes
1	Maximum reduction rate in vertical reduction: 0: 90% 1: 73%	—
0	Undefined	—

<Remarks>

FUNC 15 Bits 7 and 6:

Selections determine how much to discard (on the recording paper) when the received data is too long and exceeds the effective record length.

FUNC 15 Bit 5:

The selection determines whether or not data is reduced in vertical direction.

FUNC 15 Bit 2:

Set whether or not the received documents are recording with the discarded portion (Specified by Bits 7 and 6).

FUNC 15 Bit 1:

This bit programs maximum reduction rate in the vertical direction. This bit should be set to 1 (on) when legal size document is reduced and printed on the A4 paper.

• FUNC 16

Bit	Contents	Link with User Function Setting
7	Adding RTI: 0: Not added 1: Add	Yes
6	Adding TTI: 0: Not added 1: Add	Yes
5	Undefined	—
4	Undefined	—
3	Undefined	—
2		
1		
0		

<Remarks>

FUNC 16 Bit 7:

The setting determines whether or not receiving terminal data is printed on received document.

FUNC 16 Bit 6:

The setting determines whether or not transmitting terminal data is recorded on received document.



• FUNC 17

Bit	Contents	Link with User Function Setting
7 6 5	Undefined	—
4 3 2	Undefined	—
1	Memory Reception (Substitution Reception) Function: 0: Not available 1: Available	Yes
0	ECM Function (Error Correction Mode): 0: Not available 1: Available	Yes

<Remarks>

FUNC 17 Bit 1:

The selections allows or disallows memory reception.

FUNC 17 Bit 0:

The selection makes ECM available or not available.

• FUNC 18

Bit	Contents	Link with User Function Setting
7	Privileged Reception setting: 0: No 1: Yes	Yes
6	JBIG function: 0: Disable 1: Enable	—
5	File Recovery Transmission setting: 0: Not available 1: Available	Yes
4	Undefined	—
3	Undefined	—
2	Department Code setting: 0: No 1: Yes	Yes
1	Undefined	—
0	Undefined	—

<Remarks>

FUNC 18 Bit 7:

This bit setting determines whether or not privileged reception is activated.

FUNC 18 Bit 6:

This bit determines whether or not JBIG function is enabled or disabled.

FUNC 18 Bit 5:

This bit setting determines whether or not file recovery is available.

FUNC 18 Bit 2:

This bit setting determines whether or not the department control function is available.

• FUNC 19

Bit	Contents	Link with User Function Setting
7 6	Cover Sheet Setting and Transmitting operations: 00: Prohibited 01: Allowed 10: Not used 11: Allowed (cover image)	Yes
5	Account Code Setting: 0: Prohibited 1: Allowed	Yes
4	Department code in transmit header: 0: Not added 1: Add	—
3	Undefined	—
2	Secure Reception function: 0: Prohibited 1: Allowed	Yes
1	Undefined	—
0	Quick Polling Communication: 0: Prohibited 1: Allowed	—

<Remarks>

FUNC 19 Bits 7 and 6:

This bit determines whether or not the cover sheet is transmitted together with the document.

FUNC 19 Bit 5:

This bit determines whether or not the account code is added.

FUNC 19 Bit 4 :

This bit determines whether or not department code is recorded.

FUNC 19 Bit 2:

This bit determines whether or not security reception is performed.

FUNC 19 Bit 0:

This bits determines whether or not quick polling is carried out.

• FUNC 20

Bit	Contents	Link with User Function Setting
7	Undefined	—
6	Undefined	—
5	Undefined	—
4	Undefined	—
3	Receive Mode Setting Value: 0: TEL (manual receive mode) 1: FAX (auto receive mode)	Yes
2	TTI off setting operation for user: 0: Disable 1: Enable	—
1	Transmission report off setting operation for user: 0: Disable 1: Enable	—
0	Undefined	—

<Remarks>

FUNC 20 Bit 3:

The selections allow for either auto (FAX) or manual (TEL) reception mode.

FUNC 20 Bit 2:

Enables or disables the Transmission Header print mode.

FUNC 20 Bit 1:

Enables or disables the Transmission Report print mode.

• FUNC 21

Bit	Contents	Link with User Function Setting
7 6 5 4	Minimum counter of CI detection: 0001 to 1111 ... counts up for each time. 0000: 1 time 0001: 1 time 0010: 2 times . . . 1111: 15 times	—
3 2 1	CI ring volume value: 000: Level 0 (off) 001: Level 1 010: Level 2 011: Level 3 100: Level 4 101: Level 5 110: Level 6 111: Level 7 (maximum)	Yes
0	Undefined	—

<Remarks>

FUNC 21 Bits 7 to 4:

Minimum number of CI (Call-in) until connection with the remote party is established.

The minimum number of rings until automatic reception is initialized depends on this setting.

FUNC 21 Bits 3 to 1:

These bits determine the CI ring volume.

• FUNC 22

Bit	Contents	Link with User Function Setting
7 6 5 4	Maximum redial counter setting: 0001 to 1110 ... counts up for each time. 0000: No retry 0001: 1 time 0010: 2 times . . 1110: 14 times 1111: Undefined	—
3 2 1 0	Minimum redial counter setting: 0001 to 1110 ... counts up for each time. 0000: No retry 0001: 1 time 0010: 2 times . . 1110: 14 times 1111: Undefined	—

<Remarks>

FUNC 22 Bits 7 to 4:

Sets the maximum number of redial attempts.

FUNC 22 Bits 3 to 0:

Sets the minimum number of redial attempts.

• FUNC 23

Bit	Contents	Link with User Function Setting
7 6 5 4	Maximum redial interval counter setting: 0001 to 1110 ... counts up for each minute. 0000: 1 minute 0001: 1 minute 0010: 2 minutes . . 1111: 15 minutes	—
3 2 1 0	Minimum redial interval counter setting: 0001 to 1110 ... counts up for each minute. 0000: 1 minute 0001: 1 minute 0010: 2 minutes . . 1111: 15 minutes	—

<Remarks>

FUNC 23 Bits 7 to 4:

Sets the maximum time intervals between redials.

FUNC 23 Bits 3 to 0:

Sets the minimum time intervals between redials repeating the statement over again.

• FUNC 24

Bit	Contents	Link with User Function Setting
7 6	Priority of recording items in Journal and TX report: 00: Telephone Number > ID > Name 01: Name > Telephone Number > ID 10: ID > Telephone Number > Name 11: ID > Name > Telephone Number	—
5	SUB/PWD/SEP Communication: 0: Not available 1: Available	—
4	Scanned page when memory is overed: 0: Delete 1: Send	Yes
3	Undefined	—
2	Line monitor for user mode: 0: OFF 1: ON	Yes
1	Undefined	—
0	Always monitoring the communication line: 0: Not monitored 1: Monitored	—

<Remarks>

FUNC 24 Bits 7 and 6:

Sets the order of information to be printed in the journal and TX report information.

FUNC 24 Bit 5:

Sets the availability or non-availability of SUB/PWD/SEP communication.

FUNC 24 Bit 3:

Sets the unit to allow or disallow reduction during copying mode.

FUNC 24 Bit 2:

This bit programs whether or not the transmission communication section programmed with FUNC 6 Bit 1 is monitored.

FUNC 24 Bit 0:

Sets the unit to monitor or not monitor the communication line.



• FUNC 25

Bit	Contents	Link with User Function Setting
7	Facsimile Separator Page Setting: 0: OFF 1: ON	Yes
6	Undefined	—
5	Undefined	—
4	Undefined	—
3	Undefined	—
2	Letter Head Paper:	—
1	000: OFF	
0	001: Cassette 1	
	010: Cassette 2	
	011: Cassette 3	
	100: Cassette 4	
	111: Bypass	
	101-110: Undefined	

<Remarks>

FUNC 25 Bit 7:

Facsimile Separator Page is a sheet automatically inserted between each received fax.

FUNC 25 Bits 2 to 0:

These bits select the Letter Head Paper Tray Option.

• FUNC 26

Bit	Contents	Link with User Function Setting
7 6	Undefined	—
5	Undefined	—
4	Undefined	—
3 2 1 0	Undefined	—

• **FUNC 27**

Bit	Contents	Link with User Function Setting
7	Undefined	—
6	Undefined	—
5 4	Transmission time on same speed: 00: 4 times 01: 3 times 10: 2 times 11: 1 time	—
3 2	Reception time on same speed (V.34 only): 00: 4 times 01: 3 times 10: 2 times 11: 1 time	—
1	Use of V.34 Modem: 0: Prohibited 1: Allowed	—
0	V.34 Modem Initial Speed: 0: 28,800 bps 1: 33,600 bps	—

<Remarks>

FUNC 27 Bits 5 and 4:

Sets the number of times the unit attempts transmission of a page at the same transmission speed in ECM mode.

FUNC 27 Bits 3 and 2:

Sets the number of times the unit attempts reception of a page at the same reception speed of the V.34.

FUNC 27 Bit 1:

Bit setting allows the user to use or not use the V.34 modem.

FUNC 27 Bit 0:

Bit setting allows the user to choose the speed at which the V.34 modem operates.

• FUNC 28

Bit	Contents	Link with User Function Setting
7 6 5 4	Transmission attenuator value for V.34 modem: Counted up in the range from 0000 to 1111, in units of -1 dB. 0000 to 1111 ... counts up for every -1dB. 0000: 0 dB 0001: -1 dB 0010: -2 dB . 1001: -9 dB . 1111: -15 dB	—
3 2 1 0	Undefined	—

<Remarks>

FUNC 28 Bits 7 to 4:

The bit settings allow the user to program the modem transmission attenuation level. The smaller the set value, the higher the transmission level becomes. If errors occur frequently or training is not sent, the transmission level should be changed, as a rule.

• FUNC 29

Bit	Contents	Link with User Function Setting
7 6 5	Date format of clock: 000: MM-DD-YY 001: DD-MM-YY 010: YY-MM-DD 011: MM-DD-YYYY 100: Undefined 101: DD-MM-YYYY 110: YYYY-MM-DD 111: Undefined	Yes
4	Month format of clock: 0: Numeric 1: Alphabets	Yes
3	Time display of clock: 0: 24-hour system 1: 12-hour system (AM/PM)	Yes
2	Undefined	—
1	Undefined	—
0	Undefined	—

<Remarks>

FUNC 29 Bits 7 and 5:

Bit settings allow the user to choose the format for displaying the date.

FUNC 29 Bit 4:

Bit setting allows the Date Format to be set for either Alphabet or numeric.

FUNC 29 Bit 3:

Bit setting allows the user to choose between the 24-hour or the 12-hour system.

• FUNC 30

Bit	Contents	Link with User Function Setting
7 6	Undefined	—
5 4 3 2 1 0	Undefined	—

• FUNC 31

Bit	Contents	Link with User Function Setting
7 6 5	Print report after a ITU-T relay transmission (Originator): 00X: Do not print 010: Always 011: On error 110: Always (with send document) 111: On error (with send document)	Yes
4 3 2	Print report after a ITU-T relay transmission (Relay Station): 00X: Do not print 010: Always 011: On error 110: Always (with send document) 111: On error (with send document)	Yes
1	ITU-T Relay Station Reception List: 0: Do not print 1: Print	Yes
0	Undefined	—

<Remarks>

FUNC 31 Bits 7 to 5:

These bits program whether or not the relay transmission report is printed and the conditions for printing.

FUNC 31 Bits 4 to 2:

These bits program whether or not the relay broadcast transmission report is printed and the conditions for printing.

FUNC 31 Bit 1:

Determines whether the relay reception list is printed, and the conditions for printing.

• FUNC 32

Bit	Contents	Link with User Function Setting
7 6 5	Print report after a Relay Transmission (End Station): 00X: Do not print 010: Always 011: On error 110: Always (with send document) 111: On error (with send document)	Yes
4	A5 Size Transmission Report print after a Direct Document Transmission: 0: Do not Print 1: Print	—
3	A5 Size Transmission Report print after a Memory Transmission: 0: Do not Print 1: Print	—
2 1 0	Journal Print Page (Key default): 000: Do not Print 001: 50 communications 010: 100 communications 011: 150 communications	—

<Remarks>

FUNC 32 Bits 7 to 5:

These bits select whether or not the transmission report at the end station is transmitted to the originator by the relay station.

FUNC 32 Bit 4:

This bit select whether or not the Direct Transmission Report is print on A5 size paper.

FUNC 32 Bit 3:

This bit select whether or not the Memory Transmission Report is print on A5 size paper.

FUCN 32 Bits 2 to 0:

Sets the number of communication to be printed on Journal (automatic print).



• FUNC 33

Bit	Contents	Link with User Function Setting
7 6 5	Speaker volume for Key touch tone: 000: Level 0 (OFF) 001: Level 1 010: Level 2 011: Level 3 100: Level 4 101: Level 5 110: Level 6 111: Level 7 (maximum)	Yes
4 3 2 1 0	Languages in LCD display and report: 00000: English 00001: Italian 00010: Germany 00011: Spanish 00100: Br Portuguese 00101: Dutch 00110: Swedish 00111: Finnish 01000: Norwegian 01001: Portuguese 01010: Danish 01011: French 01100: Ca French 01101: Japanese 01110: Czech 01111: Polish 10000: Rumanian 10001: Hungarian 10010: Greek	Yes

<Remarks>

FUNC 33 Bits 7 to 5:

Allows the user to adjust the Key Touch Tone volume level.

FUNC 33 Bits 4 to 0:

These bits select the language for messages and list indication.

• FUNC 34

Bit	Contents	Link with User Function Setting
7 6 5	Undefined	—
4 3 2	Undefined	—
1	Undefined	—
0	Undefined	—

• **FUNC 35**

Bit	Contents	Link with User Function Setting
7 6 5 4	Receive Interval Setting: 0000 to 1111 counts up for each minute. 0000: 0 minute (=OFF) 0001: 1 minute 0010: 2 minutes . . . 1110: 14 minutes 1111: 15 minutes	Yes
3	Undefined	—
2	Weekly timer 0: Off 1: On	Yes
1	Auto supplies order number 0: 1 order 1: 2 order	—
0	Ext. field bit comm. Function 0: comm 1: comm Err.	—

<Remarks>

FUNC 35 Bits 7 to 4:

This function insures, there will be a period of time set aside receiving incoming facsimiles during periods of heavy outgoing transmission activity. After every fourth consecutive transmission, this machine will wait incoming facsimiles to be received.

FUNC 35 Bit 2:

Select enabling/disabling timer setup for days of the week.

FUNC 35 Bit 1:

Select the number of sets for supplies order. (0: 1 set, 1: 2 sets)

FUNC 35 Bit 0:

0: When the extended bit is on for the DIS or DTC signal and there is no subsequent bit information, the communication is enabled, regarding the sequence up to the extend bit as valid.

1: When the extended bit is on for the DIS or DTC signal and there is no subsequent bit information, the communication error will result.

• FUNC 36

Bit	Contents	Link with User Function Setting
7	Undefined	—
6		
5		
4		
3		
2		
1		
0		

• FUNC 37

Bit	Contents	Link with User Function Setting
7	Undefined	—
6		
5		
4		
3		
2		
1		
0		

• **FUNC 38**

Bit	Contents	Link with User Function Setting
7	Undefined	—
6		
5		
4		
3		
2		
1		
0		

• **FUNC 39**

Bit	Contents	Link with User Function Setting
7	Undefined	—
6		
5		
4		
3		
2		
1		
0		

## (2) PC FUNC 0-7

The settings here are PC functions, which are divided into 8 tables. Each table has functions of 8 Bits. By entering 0 or 1 in each Bit, its function can be set. The following are details of each table.

### • PC FUNC 0

Bit	Contents	Link with User Function Setting
7	Use of PC Interface: 0: Use prohibited 1: Use allowed	—
6 5	Send the Receive Documents to PC: PC transfer method at reception 00: No transfer 01: SUB-Address (Only when transferred from the sender) 10: All documents 11: Undefined	—
4	Undefined	—
3	Communication Log Management: Informing of communication journal to PC print 0: Do not inform 1: Inform	—
2	LDC Function: 0: Prohibited 1: Allowed	—
1	Printing Function: 0: Prohibited 1: Allowed	—
0	Scanner Function: 0: Prohibited 1: Allowed	—

<Remarks>

PC FUNC 0 Bit 7:

This switch allows or prohibits use of the PC interface.

PC FUNC 0 Bits 6 and 5:

If "00" is selected, the data is not sent to the PC. If "SUB Address" is selected, the data is sent to the PC only when the sub address is received from the transmitting party. If "All documents" is selected, all received data are sent to the PC.

PC FUNC 0 Bit 3:

This bit selects whether or not the journal is sent to the PC.

PC FUNC 0 Bit 2:

This switch allows or prohibits any entry or dialing from the PC.  
Used in conjunction with PC interface software.

PC FUNC 0 Bit 1:

This switch allows or prohibits any entry from the PC.

PC FUNC 0 Bit 0:

This switch allows or prohibits scanning directed from the PC.

• PC FUNC 1

Bit	Contents	Link with User Function Setting
7	Undefined	—
6	Undefined	—
5	Undefined	—
4	Print Rx document after sending to PC: 0: Off 1: On	—
3	Permanent retry to send the RX data: 0: Off 1: On	—
2	Undefined	—
1	Undefined	—
0	Undefined	—

<Remarks>

PC FUNC 1 Bit 4:

This bit function is print RX document, after the transmission RX data to PC.

PC FUNC 1 Bit 3:

This bit selects whether or not to continue to transfer the received file until the number of retries set as the transfer retry counter is reached, when the FAX failed to transfer the received file to a PC at PC FAX reception.



• PC FUNC 2

Bit	Contents	Link with User Function Setting
7 6 5 4	Undefined	—
3 2 1 0	Undefined	—

• PC FUNC 3

Bit	Contents	Link with User Function Setting
7 6 5 4	Retry Counter value at PC transfer: 0000 to 1111 ... counts up for each retry. 0000: No retry 0001: 1 retry 0010: 2 retries . . 1111: 15 retries	—
3 2 1 0	Retry interval for PC transfer: 0001 to 1111 ... counts up for each minute. 0000: default (2 minutes) 0001: 1 minute 0010: 2 minutes . . 1111: 15 minutes	—

<Remarks>

PC FUNC 3 Bits 7 to 4:

This switch specifies the number of retries for data transmission to the PC.

PC FUNC 3 Bits 3 to 0:

This switch specifies the time intervals between retries in data transmission to the PC.

• PC FUNC 4

Bit	Contents	Link with User Function Setting
7 6 5 4	Retry counter for STAT message to PC: 0000: No retry 0001: 1 retry . . . 1111: 15 retrys	—
3 2 1 0	Time between retry attempts for STAT message: 0000: default (2 minutes) 0001: 1 minute . . . 1111: 15 minutes	—

<Remarks>

PC FUNC 4 Bits 7 to 4:

Set the number of retries to notify the PC of fax status information via PC interface.

PC FUNC 4 Bits 3 to 0:

Set the intervals of retries to notify the PC of fax status information via PC interface.

• PC FUNC 5

Bit	Contents	Link with User Function Setting
7	RX cover open 0: Off 1: On	—
6	Printer Error 0: Off 1: On	—
5	Print jam 0: Off 1: On	—
4	No process unit 0: Off 1: On	—
3	Heater Error 0: Off 1: On	—
2	Process unit near end 0: Off 1: On	—
1	Process unit end 0: Off 1: On	—
0	Toner near end 0: Off 1: On	—

<Remarks>

PC FUNC 5 Bit 7:

Set the function to notify the PC, via PC interface, that the RX cover (including all parts around the paper supply cover) is open.

PC FUNC 5 Bit 6:

Set the function to notify the PC, via PC interface, that a printer error has occurred.

PC FUNC 5 Bit 5:

Set the function to notify the PC, via PC interface, that a printer jam has occurred.

PC FUNC 5 Bit 4:

Set the function to notify the PC, via PC interface, that the process unit is not attached.

PC FUNC 5 Bit 3:

Set the function to notify the PC, via PC interface, that a heater error has occurred.

PC FUNC 5 Bit 2:

Set the function to notify the PC, via PC interface, that the replacement of the process unit is soon required.

PC FUNC 5 Bit 1:

Set the function to notify the PC, via PC interface, that the replacement of the process unit is required.

PC FUNC 5 Bit 0:

Set the function to notify the PC, via PC interface, that the replacement of the toner cartridge is soon required.

• PC FUNC 6

Bit	Contents	Link with User Function Setting
7	Toner end 0: Off 1: On	—
6	Power on 0: Off 1: On	—
5	Memory over 0: Off 1: On	—
4	TX cover open 0: Off 1: On	—
3	Scan paper exist 0: Off 1: On	—
2	No cassette 0: Off 1: On	—
1	No paper 0: Off 1: On	—
0	Paper detect on bypass cassette 0: Off 1: On	—

<Remarks>

PC FUNC 6 Bit 7:

Set the function to notify the PC, via PC interface, that the toner has run out, via PC interface.

PC FUNC 6 Bit 6:

Set the function to notify the PC, via PC interface, that the power is turned on, via PC interface.

PC FUNC 6 Bit 5:

Set the function to notify the PC, via PC interface, that a memory full state has occurred.

PC FUNC 6 Bit 4:

Set the function to notify the PC, via PC interface, that the TX cover (DF cover (excluding the platen cover)) is open.

PC FUNC 6 Bit 3:

Set the function to notify the PC, via PC interface, that the paper detection sensor has detected the original.

PC FUNC 6 Bit 2:

Set the function to notify the PC, via PC interface, that no paper cassette exists.

PC FUNC 6 Bit 1:

Set the function to notify the PC, via PC interface, that no paper is loaded.

PC FUNC 6 Bit 0:

Set the function to notify the PC, via PC interface, that paper is loaded on the stack feed bypass.

• PC FUNC 7

Bit	Contents	Link with User Function Setting
7 6 5 4 3 2 1 0	Undefined	—



### (3) HOME 0-2

- HOME 0

Bit	Contents	Link with User Function Setting
7 6	Undefined	—
5 4 3	Undefined	—
2	Undefined	—
1	Undefined	—
0	Undefined	—

- HOME 1

Bit	Contents	Link with User Function Setting
7	Undefined	—
6	Undefined	—
5	Undefined	—
4 3	Undefined	—
2 1 0	Undefined	—

• HOME 2

Bit	Contents	Link with User Function Setting
7	Undefined	—
6	Undefined	—
5		
4		
3		
2	Undefined	—
1		
0		

#### (4) UAD 0-19

The following settings are special functions relating to telephone specifications for each country. The functions are divided into 20 tables. Each table has functions of 8 Bits. By entering 1 or 0 in each Bit, its function are set.

##### • UAD 0

Bit	Contents	Link with User Function Setting
7 6 5	Range of dial tone frequency (PSTN): 000: 300Hz to 600Hz 001: 300Hz to 650Hz 010: 390Hz to 550Hz 011: 400Hz to 450Hz 100: 350Hz to 480Hz 101: 300Hz to 500Hz 110: Reserved 111: Reserved	—
4 3 2	Detection time to recognize as dial tone (PSTN): 000: 2 sec. 001: 800 msec. 010: 400 msec. 011: 1 sec. 100: 1.3 sec. 101: 1.8 sec. 110: 2.5 sec. 111: 500 msec.	—
1 0	Allowable gap during line current detection (PSTN): 00: Off 01: 50 msec. 10: 100 msec. 11: 200 msec.	—

<Remarks>

UAD 0 Bits 7 to 5:

Sets the range of the dial tone frequency that should be detected when calling directly to a PSTN.

UAD 0 Bits 4 to 2:

Sets the time when the dial tone is recognized when calling directly to a PSTN. When a dial tone is continuously detected for the time specified, the facsimile regards the line as being connected.

UAD 0 Bits 1 and 0:

Sets the allowable gap during line current detection when calling directly to a PSTN. In line current detection, even if there are gaps within the time specified in this setting, the counter is not reset and continues to count the duration of line current detection after the current is re-detected.

When "BZT" is selected for "DTC/LCC for PSTN" in UAD 1, this setting is ignored.

• UAD 1

Bit	Contents	Link with User Function Setting
7 6	Allowable gap during dial tone detection (PSTN): 00: Off 01: 70 msec. 10: 160 msec. 11: 240 msec.	—
5 4 3	Method to detect dial tone and line current (PSTN): 000: BZT (DTC/LCC) 001: LCC 5 sec. 010: DTC only 011: Undefined 100: DTC (USA) 101: LCC 3 sec. 110: Undefined 111: No Check	—
2 1 0	Maximum waiting time for dial tone (PSTN): 000: 20 sec. 001: 10 sec. 010: 8 sec. 011: 15 sec. 100: 3.3 sec. 101: Undefined 110: Undefined 111: Undefined	—

<Remarks>

UAD 1 Bits 7 and 6:

Sets the allowable gap during dial tone detection when calling directly to a PSTN. In dial tone detection, even if there are gaps within the time specified in this setting, the counter is not reset and continues to count the duration of dial tone detection after the dial tone whose frequency is in the specified range is re-detected.

UAD 1 Bits 5 to 3:

Sets the method to detect the dial tone and line current when calling directly to a PSTN.

- BZT (DTC/LCC)      Performs German BZT type of detection
- LCC 5 sec.            Only 5 sec. Line current is detection
- DTC only             Only dial tone is detected.
- DTC (USA)            Only dial tone is detected. Duration of detected tone until it is regarded as the dial tone is fixed 3.3 msec. Even if no dial tone is detected, dialing will be started.
- LCC 3 sec.            3 second line current detection is performed.
- No check             Neither dial tone nor line current is detected.

UAD 1 Bits 2 to 0:

Sets the maximum waiting time for dial tone detection when calling directly to a PSTN. If the dial tone is not detected and redial attempt or internal retry will be performed later.

• UAD 2

Bit	Contents	Link with User Function Setting
7 6 5	Range of dial tone frequency (PABX): 000: 300Hz to 600Hz 001: 300Hz to 650Hz 010: 390Hz to 550Hz 011: 400Hz to 450Hz 100: 350Hz to 480Hz 101: 300Hz to 500Hz 110: Reserved 111: Reserved	—
4 3 2	Detection time to recognize as dial tone (PABX): 000: 2 sec. 001: 800 msec. 010: 400 msec. 011: 1 sec. 100: 1.3 sec. 101: 1.8 sec. 110: 2.5 sec. 111: 150 msec.	—
1 0	Allowable gap during line current detection (PABX): 00: Off 01: 50 msec. 10: 100 msec. 11: 200 msec.	—

<Remarks>

UAD 2 Bits 7 to 5:

Sets the range of the dial tone frequency that should be detected when calling through a PABX.

UAD 2 Bits 4 to 2:

Sets the time when the dial tone is recognized when calling through a PABX. When a dial tone is continuously detected for the time specified in this setting, the facsimile regards the line as being connected.

UAD 2 Bits 1 and 0:

Set the allowable gap during line current detection when calling through a PABX. In line current detection, even if there are gaps within the time specified in this setting, the counter is not reset and continues to count the duration of line current detection after the current is re-detected.

• UAD 3

Bit	Contents	Link with User Function Setting
7 6	Allowable gap during dial tone detection (PABX): 00: Off 01: 70 msec. 10: 160 msec. 11: 240 msec.	—
5 4 3	Method to detect dial tone and line current (PABX): 000: BZT (DTC/LCC) 001: LCC 5 sec. 010: DTC only 011: Undefined 100: DTC (USA) 101: LCC 3 sec. 110: Undefined 111: No Check	—
2 1 0	Maximum waiting time for dial tone (PABX): 000: 20 sec. 001: 10 sec. 010: 8 sec. 011: 15 sec. 100: 3.3 sec. 101: Undefined 110: Undefined 111: Undefined	—



<Remarks>

UAD 3 Bits 7 and 6:

Sets the allowable gap during dial tone detection when calling through a PABX. In dial tone detection, even if there are gaps within the time specified in this setting, the counter is not reset and continues to count the duration of dial tone detection after the dial tone whose frequency is in the specified range is re-detected.

UAD 3 Bits 5 to 3:

Sets the method to detect the dial tone and line current when calling through a PABX.

- BZT (DTC/LCC)      Performs German BZT type of detection
- LCC 5 sec.            Only 5 sec. Line current is detection
- DTC only             Only dial tone is detected.
- DTC (USA)           Only dial tone is detected. Duration of detected tone until it is regarded as the dial tone is fixed 3.3 msec. Even if no dial tone is detected, dialing will be started.
- LCC 3 sec.            3 second line current detection is performed.
- No check             Neither dial tone nor line current is detected.

UAD 3 Bits 2 to 0:

Sets the maximum waiting time for dial tone detection when calling through a PABX. If the dial tone is not detected and redial attempt or internal retry will be performed later.

• UAD 4

Bit	Contents	Link with User Function Setting
7 6 5	Busy tone frequency range: 000: 300Hz to 600Hz 001: 350Hz to 550Hz 010: 300Hz to 500Hz 011: 300Hz to 700Hz 100: Reserved 101: Reserved 110: Reserved 111: Reserved	—
4	Busy tone before dialing: 0: No check 1: Check	—
3	Busy tone after dialing: 0: No check 1: Check	—
2 1 0	Dial T1 timer: 000: 60 sec. 001: 35 sec. 010: 90 sec. 011: 55 sec. 100: 145 sec. 101: Undefined 110: Undefined 111: Undefined	—

<Remarks>

UAD 4 Bits 7 to 5:

Sets the range where a busy tone frequency is detected.

UAD 4 Bit 4:

Set whether a busy tone is detected before dialing as well as the dial tone and line current.

UAD 4 Bit 3:

Set whether a busy tone is detected after dialing as well as the dial tone and line current.

UAD 4 Bits 2 to 0:

Sets the value of the T1 timer in the calling terminal.

• UAD 5

Bit	Contents	Link with User Function Setting
7	USCC #12: 0: Enable 1: Disable	—
6	Undefined	—
5	Undefined	—
4	Undefined	—
3	Undefined	—
2	Undefined	—
1	Undefined	—
0		

<Remarks>

UAD 5 Bit 7:

If T1 time-out (no response from remote) occurs continuously 12 time in automatic dialing, all of the programmed calling jobs are cleared.

- The counter is reset when an effective signal is detected.
- The number of T1 time-out in automatic dialing is counted (manual dialing not included).

• UAD 6

Bit	Contents	Link with User Function Setting
7 6	Type of dial pulse: 00: Normal 01: Shift 10: Reverse 11: Undefined	—
5	Undefined	—
4	Internal retry setting: 0: Disable 1: Enable	—
3 2 1 0	Dial Retry Counter: 0000 to 1110 ... counts up for each time. 0000: No redialing 0001: 1 time 0010: 2 times 0011: 3 times . . . 1110: 14 times 1111: Reserved	Yes

<Remarks>

UAD 6 Bits 7 and 6 :

Sets the type of dial pulse sent when each dial number is dialed.

Dial Key	Normal	Shift (n+1)	Reverse (10-n)
1	1	2	9
2	2	3	8
3	3	4	7
4	4	5	6
5	5	6	5
6	6	7	4
7	7	8	3
8	8	9	2
9	9	10	11
0	10	1	10

UAD 6 Bit 4:

Sets whether internal retries are performed. "Internal Retry" is the dialing attempt performed when line connection cannot be established due to a line current or dial tone not being detected before dialing. Internal retries are not counted as redial attempts.

UAD 6 Bits 3 to 0:

These bits program the number of redial times.

• UAD 7

Bit	Contents	Link with User Function Setting	
7	Alternate time when a pause is set as part of a dial number: 000:None (0 sec.) 001: 1 sec. 010: 2 sec. 011: 4 sec. 100: 3.3 sec. 101: 10 sec. 110: Undefined 111: Undefined	—	
6		—	
5		—	
4		Undefined	—
3		Undefined	—
2			
1			
0			

<Remarks>

UAD 7 Bits 7 to 5:

These bits programs the switch time when a pause is entered as a part of a dial number.

• UAD 8

Bit	Contents	Link with User Function Setting
7 6	Inter-digit pause setting: 00: 900 msec. 01: 550 msec. 10: 700 msec 11: 800 msec.	—
5	Single pause setting: 0: Disable 1: Enable	—
4	Undefined	—
3 2 1 0	Interval between redialing attempts: 0001 to 1111 ... counts up for each minute. 0000: default (3 minutes) 0001: 1 minute 0010: 2 minutes . . . 1111: 15 minutes	Yes

<Remarks>

UAD 8 Bits 7 and 6:

Sets the pause time that is put between dial digits in pause dialing.

UAD 8 Bit 5:

When "Enable" is selected, only the first pause is effective and others are ignored even if the pause key is pressed more than once in dialing to one destination.

UAD 8 Bits 3 to 0:

These bits program the redial intervals.

• UAD 9

Bit	Contents	Link with User Function Setting
7 6	Equalizer Value at MF Dialing: 00: 0 dB 01: -4 dB 10: -8 dB 11: -12 dB	—
5 4 3	DP Make/Break: 000: 60/40 msec. (10 PPS) 001: 67/33 msec. (10 PPS) 010: 63/37 msec. (10 PPS) 011: 50/50 msec. (10 PPS) 100: 67/33 msec. (20 PPS) 101: for TW (33.3%) 110: Undefined 111: Undefined	—
2 1 0	MF Timing: 000: 80/80 msec. 001: 70/70 msec. 010: 70/150 msec. 011: 60/60 msec. 100: 80/100 msec. 101: 150/50 msec. 110: 150/240 msec. 111: Undefined	—

<Remarks>

UAD 9 Bits 7 and 6:

These bits program the equalizer value for the MF signal.

UAD 9 Bits 5 to 3:

Sets the make time and brake time during pulse dialing.

UAD 9 Bits 2 to 0:

Sets the tone on and tone off times for tone dialing (MF).



• UAD 10

Bit	Contents	Link with User Function Setting
7 6 5	Dial tone reception attenuation (PSTN): 000: -24dB 001: -27dB 010: -30dB 011: -33dB 100: -36dB 101: -39dB 110: -42dB 111: -45dB	—
4	Undefined	—
3 2 1 0	Attenuator Value at MF Dialing: 0000 to 1111 ... counts up for each -1 dB. 0000: 0 dB 0001: -1 dB 0010: -2 dB 0110: -6 dB . . . 1111: -15 dB	—

<Remarks>

UAD 10 Bits 7 to 5:

Sets the dial tone's attenuation detection level during reception (PSTN).

UAD 10 Bits 3 to 0:

These bits program the attenuator value for the MF signal.

• UAD 11

Bit	Contents	Link with User Function Setting
7 6 5	Undefined	—
4	Undefined	—
3 2 1 0	Undefined	—

• UAD 12

Bit	Contents	Link with User Function Setting
7 6 5 4	Undefined	—
3 2 1 0	Undefined	—

• UAD 13

Bit	Contents	Link with User Function Setting
7 6 5 4	Undefined	—
3 2 1 0	Undefined	—

• UAD 14

Bit	Contents	Link with User Function Setting
7 6 5 4	Undefined	—
3 2 1	Dial tone reception attenuation (PABX): 000: -24dB 001: -27dB 010: -30dB 011: -33dB 100: -36dB 101: -39dB 110: -42dB 111: -45dB	—
0	Undefined	—

<Remarks>

UAD 14 Bits 3 to 1:

Sets the dial tone's attenuation detection level during reception (PABX).

• UAD 15

Bit	Contents	Link with User Function Setting
7 6 5	Undefined	—
4 3 2	Undefined	—
1	Undefined	—
0	Undefined	—

• UAD 16

Bit	Contents	Link with User Function Setting
7 6 5	Busy Tone ON Determine Time: 000: 80 to 650 msec. 001: 450 to 550 msec. 010: 200 to 650 msec. 011: 400 to 600 msec. 100: 120 to 550 msec. 101: 420 to 610 msec. 110: Reserved 111: Reserved	—
4 3 2	Busy Tone OFF Determine Time: 000: 80 to 650 msec. 001: 450 to 550 msec. 010: 200 to 650 msec. 011: 400 to 600 msec. 100: 160 to 600 msec. 101: 170 to 700 msec. 110: 380 to 630 msec. 111: 150 to 470 msec.	—
1	Undefined	—
0	Undefined	—

<Remarks>

UAD 16 Bits 7 to 5:

These bits program busy tone signal ON time.

UAD 16 Bits 4 to 2:

These bits program busy tone signal OFF time.

• UAD 17

Bit	Contents	Link with User Function Setting
7	Undefined	—
6		
5		
4		
3		
2		
1		
0		

• UAD 18

Bit	Contents	Link with User Function Setting
7	Undefined	—
6		
5		
4		
3		
2		
1		
0		

• UAD 19

Bit	Contents	Link with User Function Setting
7	Undefined	—
6		
5		
4		
3		
2		
1		
0		

## (5) EXTYPE

The settings here are the Exchange functions. This table has functions of 8 Bits. By entering 0 or 1 in each Bit sets, its function. The following is details of this Table.

### • EXTYPE 1

Bit	Contents	Link with User Function Setting
7	Exchange Type: 0: PSTN 1: PABX	Yes
6	Undefined	—
5	Undefined	—
4	Dial Type: 0: DP 1: MF	Yes
3 2	PABX Access for Local line: 00: No Setting 01: Not Used 10: Access Digit 11: Flash	Yes
1 0	Flash timing: 00: 80 ms 01: 100 ms 10: 270 ms 11: Unfind	—

<Remarks>

EX TYPE 1 Bit 7:

This bit sets the Exchange Type (PSTN/PABX).

EX TYPE 1 Bit 4:

This bit sets the dialing method (DP/MF).

**(6) ACC DGT1-2**

The settings here are Access Digit functions, which are divided into 2 tables. Each table has functions of 8 Bits. By entering 0 or 1 in each Bit, its function can be set. The following are details of each table.

**• ACC DGT 1**

Bit	Contents	Link with User Function Setting
7 6 5 4	1st Digit (Local Use)	—
3 2 1 0	2nd Digit (Distant Use)	—

**• ACC DGT 2**

Bit	Contents	Link with User Function Setting
7 6 5 4	3rd Digit (Local & Distant Use)	—
3 2 1 0	Undefined	—



### 1.2.3 Function test

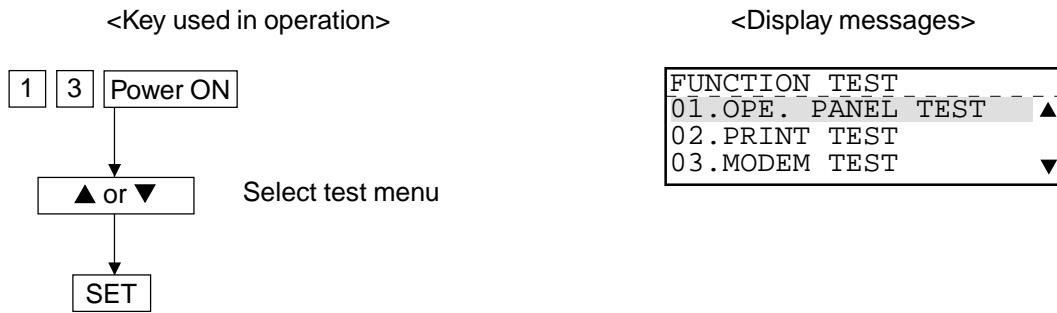

The following tests can be conducted in the function test mode.

This section only describes PRINT TEST and MODEM TEST as the functions available by attaching the fax kit. For the other tests, refer to the Service Handbook.(DP1600/2000/2500)

01. OPE PANEL TEST
02. PRINT TEST
03. MODEM TEST (Factory test)
04. SENSOR TEST
05. SRAM TEST
06. DRAM TEST
07. CLOCK IC TEST
08. SCANNER TEST
09. CODEC TEST
10. OUTPUT TEST
11. PRINTER BOARD TEST

## (1) 02. PRINT TEST

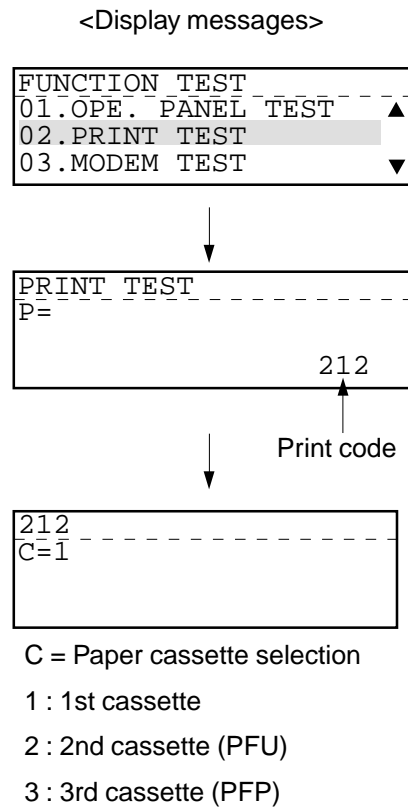
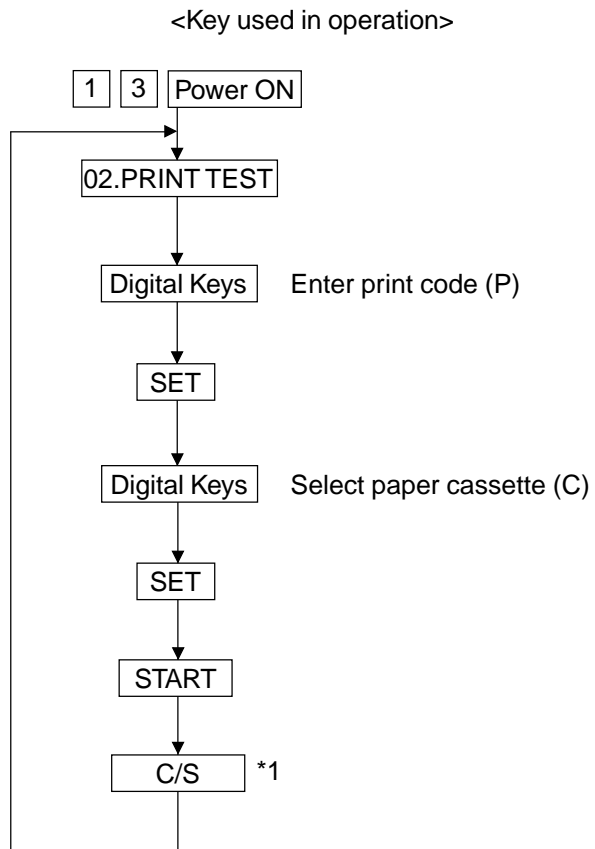

\* Be sure to press this key after printing starts. (If this key is not pressed, the copier keeps printing.)

PRINT TEST ITEM

CODE	FACTOR	TEST PATTERN ITEM		REMARKS
212	Image processing	Grid pattern	16 dot x 15.4 l/mm	FAX
213	Image processing	Grid pattern	15.4 l/mm x 16 dot	FAX

Test Pattern

<212>

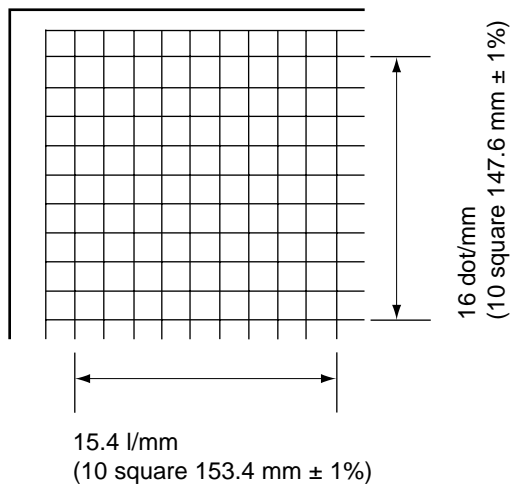

The direction of transporting

<213>

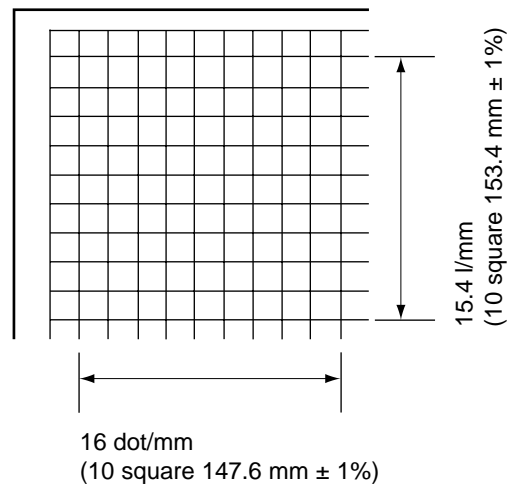

The direction of transporting

**[The adjustment of output magnification]**

It is unnecessary to adjust the fax image magnification.

If you adjust it with '05' adjustment mode of the copier side, the image magnification of the fax side will be adjusted automatically.

**(2) 03. MODEM TEST (Factory test)**

When the FAX kit is not installed, the test is not present.

This test checks signal output from the modem.

The following signals are output at frequency that is changed every time the START key is pressed once the test starts.

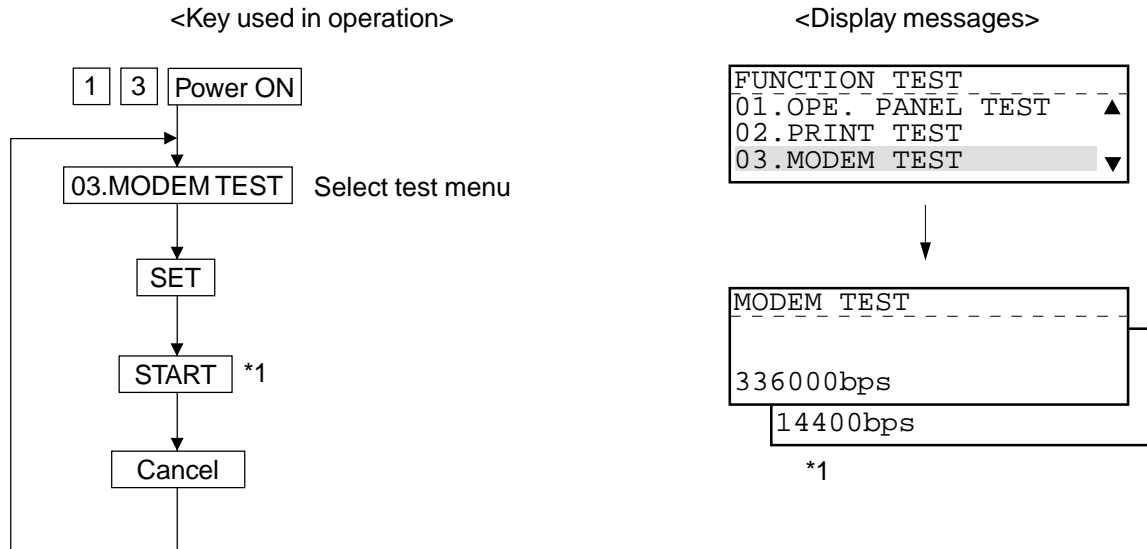

\*1: The modem's oscillation frequency changes every time the START key is pressed.

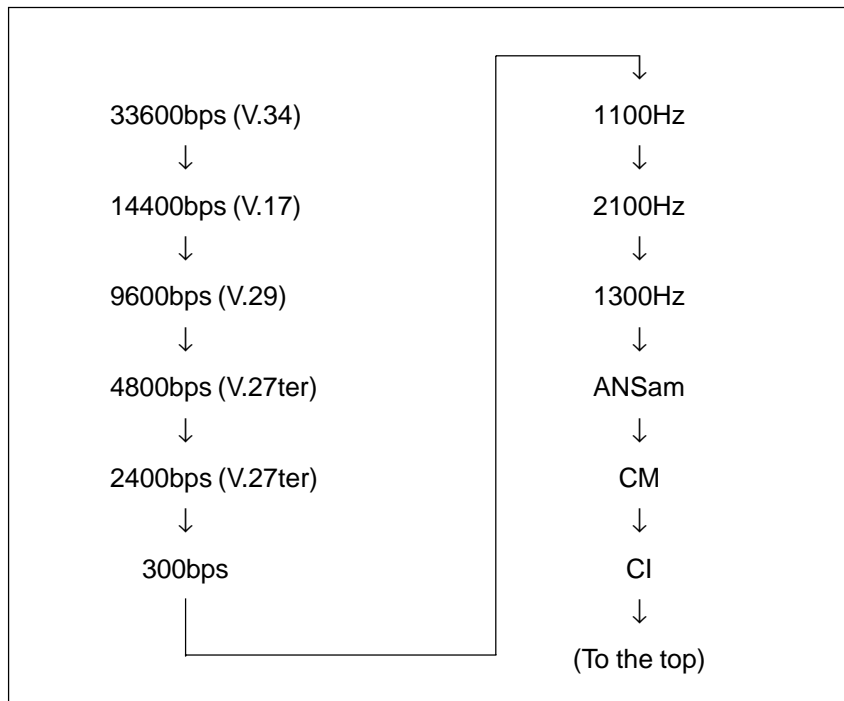

## 1.2.4 MAINTENANCE

### (1) MEMORY CLEAR

There are two ways to perform memory clear; the power on while pressing the specified keys, and partial memory clear by selecting items to be cleared from the menu.

#### Operation Procedure

##### a) Memory clear at the startup

<Key used in operation>

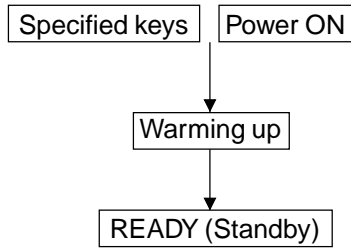

<Display messages>

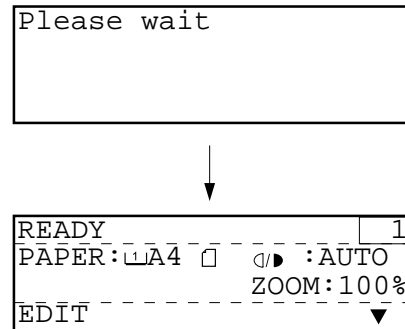

b) Item selection from menu

<Key used in operation>

When READY is displayed

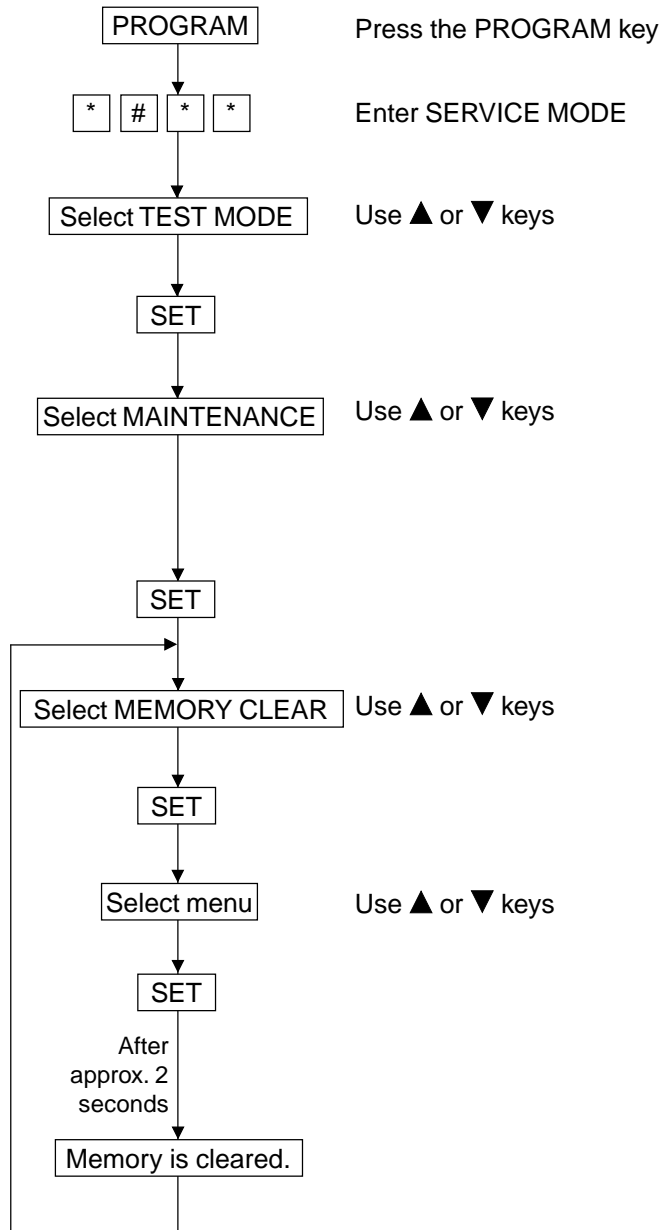

<Display messages>

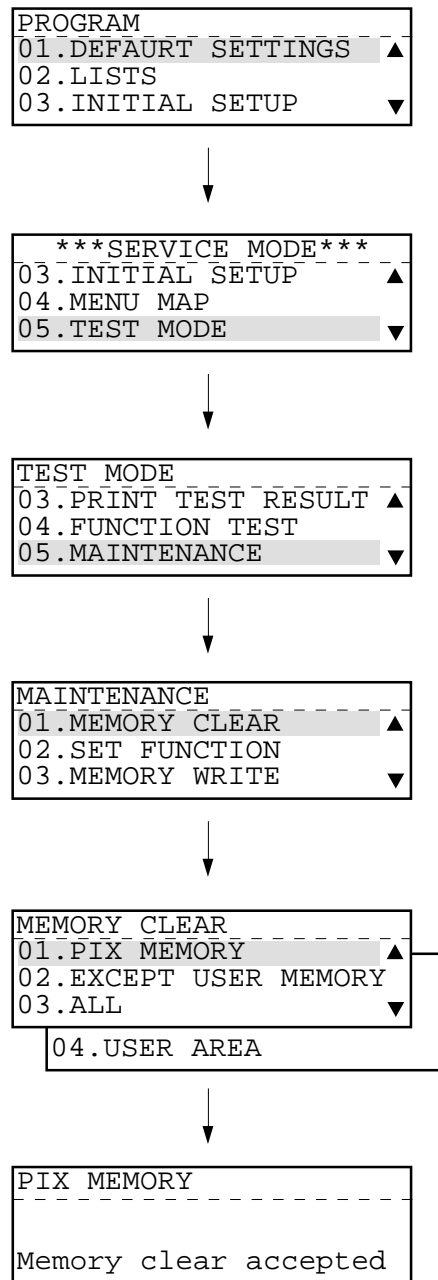

## RAM clear table

RAM data	Country setting	Service parameter setting							
		FUNC/ SYSFUNC/ UAD etc.	Service adjustment data ([0][5]) area	Service setting data ([0][8]) area	Journal report data	Error data on FAX communi- cation	Protocol trace data	Counter data *a)	Drum related data *b)
[1] [3] [*] and turn ON		Set default value		Set default value *e)	Clear	Clear	Clear		
[1] [3] [#] and turn ON							Clear	Clear	
[*] [#] and turn ON					Clear	Clear	Clear		
[START] [STOP] and turn ON		Set default value		Set default value *e)			Clear		
[0] [8] and turn ON, then [6] [6] [5] *1)			Set default value	Set default value			Clear		
[0] [2] and turn ON	Changeable	Set default value		Set default value *e)	Clear	Clear	Clear		
1. PIX MEMORY									
2. EXCEPT USER MEMORY		Set default value			Clear	Clear			
3. ALL (Same as "[1] [3] [*] and turn ON")		Set default value		Set default value *e)	Clear	Clear	Clear		
4. USER AREA							Clear		

\*1) In case of replacing the main board in the field, you can initialize the parameters related to copy function stored on the board using this function.

Therefore when this function is performed, it is necessary to readjust the following items.

- 1) Adjustment of paper aligning value
- 2) Printer unit adjustment
- 3) Scanner unit adjustment
- 4) ADF/RADF installation setting

User parameter setting								
Dial data *c)	One touch data	Department code data	Secure receive data	Station name	ID number	Password *d)	Pending FAX job data	Stored JOB data
Clear	Clear	Clear	Clear	Clear	Clear	Clear	Clear	Clear
							Clear	
								Clear
Clear	Clear	Clear	Clear	Clear	Clear	Clear	Clear	Clear
							Clear	
							Clear	
Clear	Clear	Clear	Clear	Clear	Clear	Clear	Clear	Clear
Clear	Clear	Clear	Clear	Clear	Clear	Clear	Clear	

\*a) Total Scan, Print jam, Job counter, Counter for each paper size

\*b) Total Print, Drum counter, Toner counter, etc.

\*c) One touch, Speed, Group etc.

\*d) Polling Password, Remote Access Code

\*e) 08-446, 08-447 not cleared



(2) SET FUNCTION

You can refer to and change the set values in each table (FUNC, UAD, TEL FUNC, EX TYPE, ACC DGT, PCFUNC) for function programming.

<Key used in operation>

<Display messages>

When READY is displayed

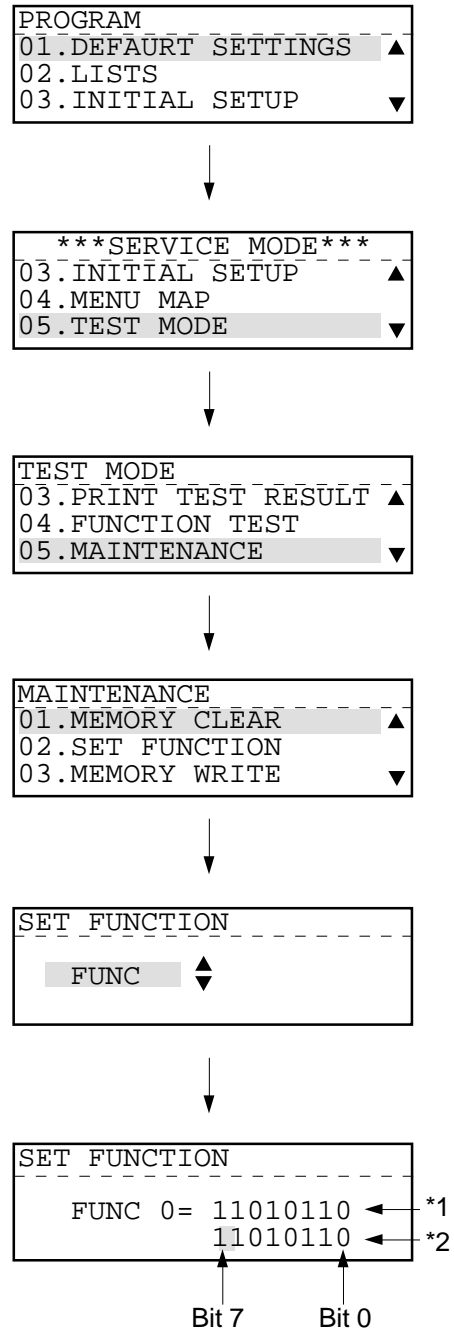
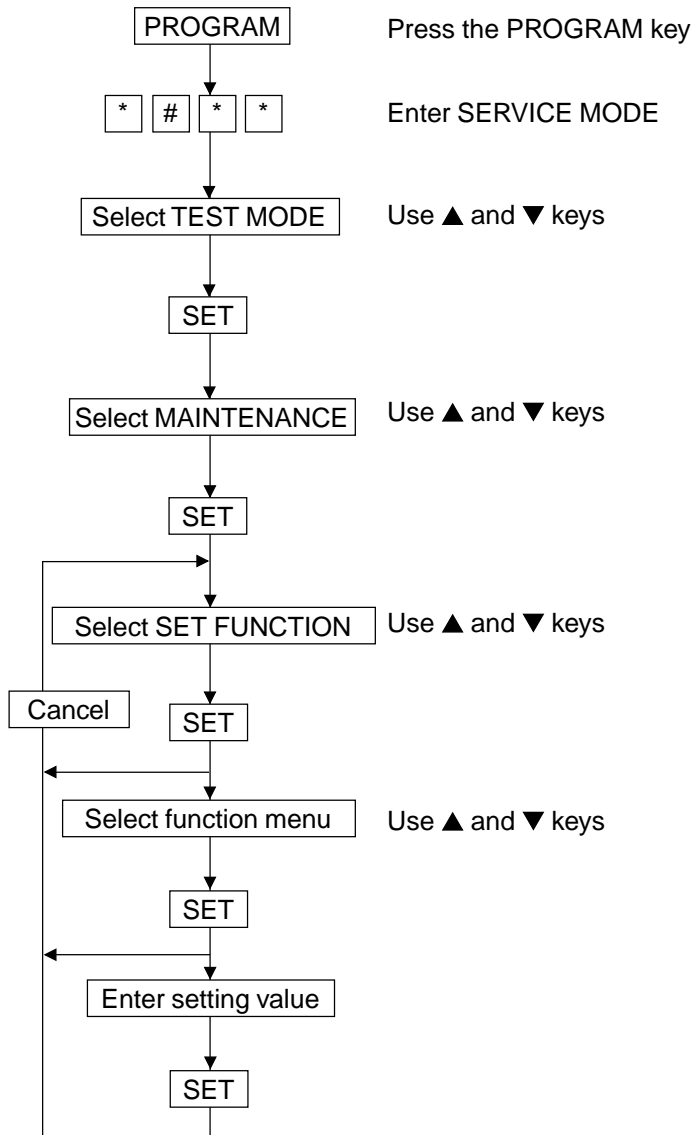

- Notes:**
- 1. \*1 : Displays the numeric value currently set (cannot be changed).
  - 2. \*2 : Displays the numeric value to be entered now (Can only be altered at the point of the cursor).
  - 3. Bit 7 is shown on the LCD display as the left most digit.
  - 4. By entering 1 or 0 in the bit with the desired function, the function is to be set.
  - 5. Press the SET key to store the new setting and advance the next function.

### (3) MEMORY WRITE

You can refer to and change the data stored at each address in the SRAM and DRAM.

ADDRESS and DATA input it with hex data.

<Key used in operation>

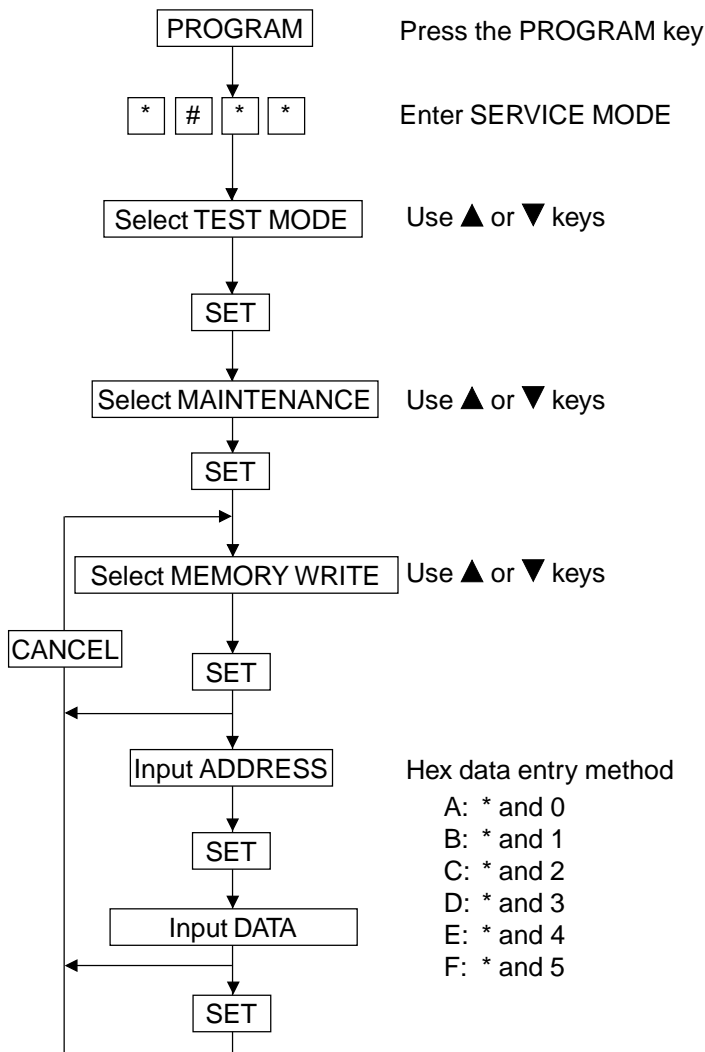

<Display messages>

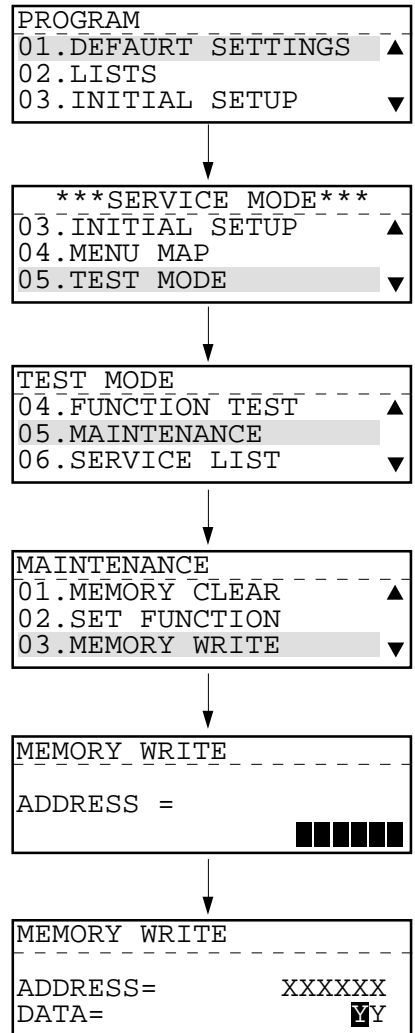

#### (4) ERROR COUNTER SHIFT

The actual information in the error count list is usually automatically moved to the history side every 1000 communications unless error counter shift is performed. Therefore, this is used to move the information to the history side before reaching 1000 communications. When error count shift is performed, the count values on the actual side of the error count list are moved to the history side and the values on the actual side are initialized. The information having been moved to the history side is added to the previous values.

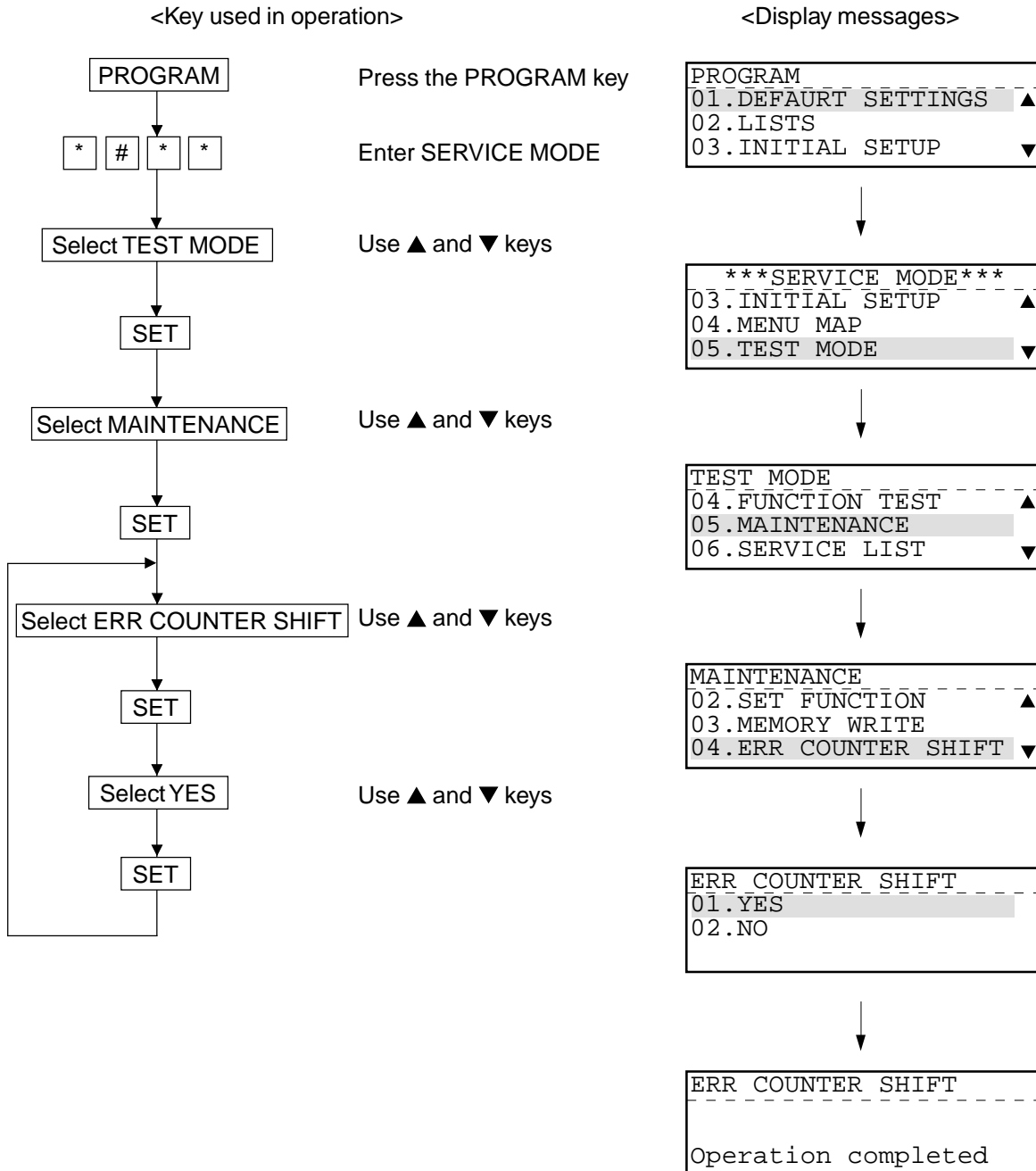

## (5) PIX MEMORY TRANSFER

When the original(s) received cannot be printed out because of printer trouble, etc., this function is used to transfer the data in pix memory to the specified location. When you select PIX MEMORY TRANSFER and specify a destination, the data in pix memory will be transferred to the specified destination.

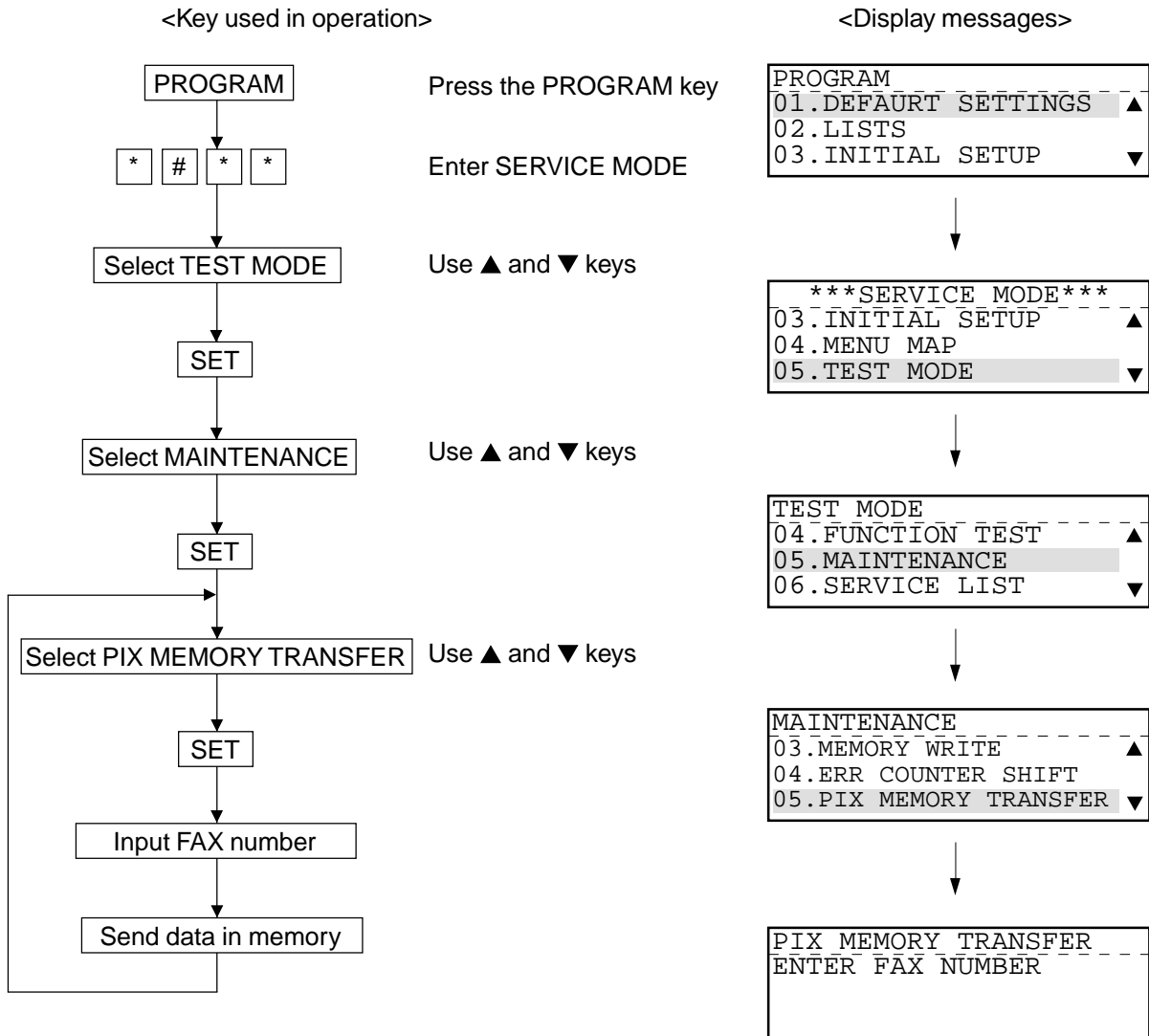

**Note:** To specify a transfer destination, you can enter the abbreviated number or press the one-touch key as well as the direct entry of the telephone number.

## 1.2.5 SERVICE LIST

This function allows you to print lists. There are six kinds of lists that can be printed.

- PROTOCOL TRACE \*1
- TOTAL ERRORS \*1
- FUNCTION (FUNC 05, 08 List)
- DRUM HISTORY
- MEMORY DUMP LIST
- FUNCTION (Jam counter, ROM ver.)

\*1: To be printed when the FAX Kit (GD-1060) is installed.

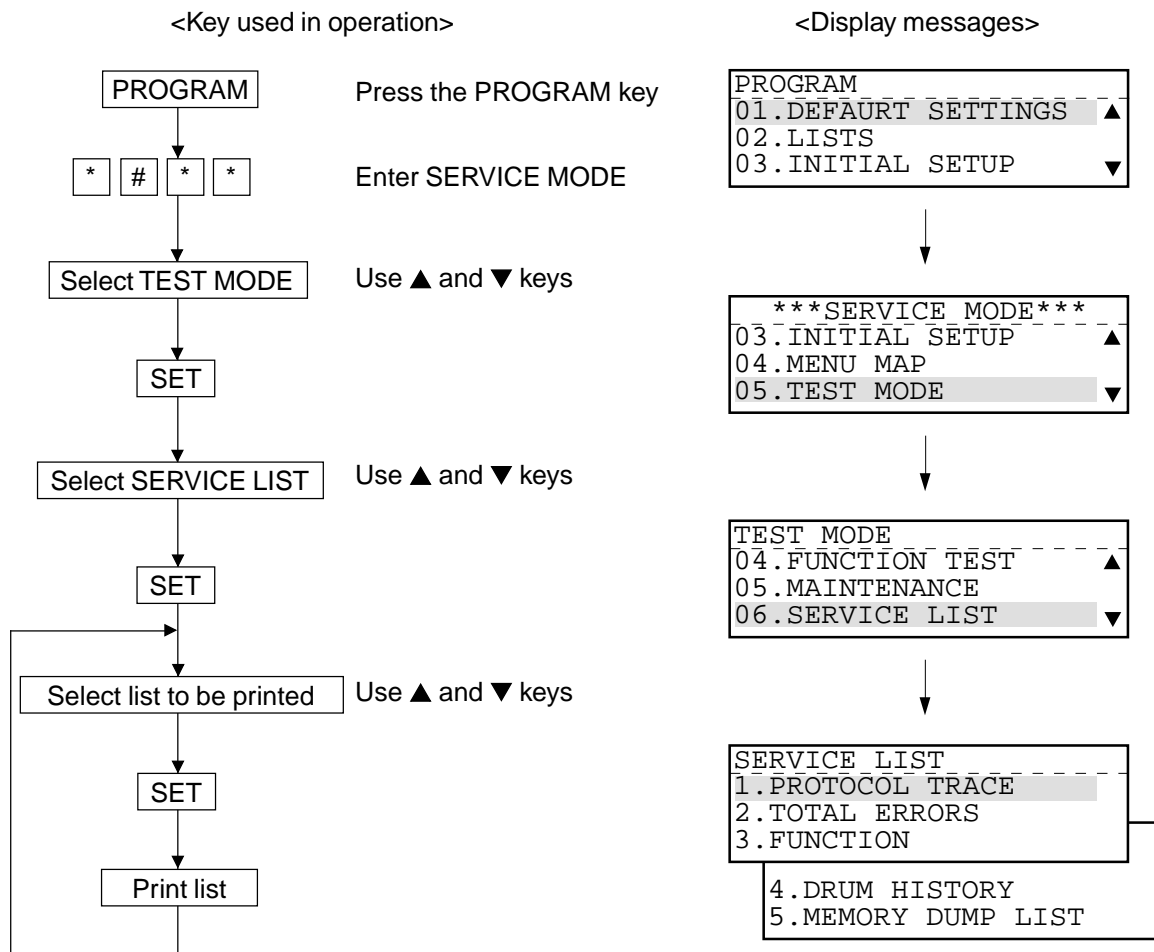

(1) PROTOCOL TRACE

This list is printed out with a title of PROTOCOL TRACE LIST. The result of the last communication job just before the list is printed out is printed out. You can check the communication protocol with this result.

Print Items

- TIME           The time when signal transmission is begun or the time when signal reception is begun is printed in "minutes : seconds."
- SEND/RCV     The send signal is printed as S, and the receive signal as R. Also, the high-speed tracing signal is printed as TCF, and the high-speed image signal as PIX.
- FCF DATA     Facsimile control field.  
The FCF       command is printed.
- FIF DATA     When there is an information field, its contents are printed in either HEX, BIN or TEL format.
- ASCII         FIF is converted to ASCII code and printed.

PROTOCOL TRACE LIST					
					XXXXXXXXXX XXXXXXXXXXXX XXXXXXXXXX XXXXX
					PAGE : 001
					TIME : NOV-15-00 04:09PM
					TEL NUMBER : 12345678901234567890
					E-MAIL : ABCDEFGHIJKLMNOPQRSTUVWXYZ12345678901234
					NAME : ABCDEFGHIJKLMNOPQRSTUVWXYZABCDEFGHIJKLMN
TIME	SEND/RCV	FCF DATA	FIF DATA	ASCII	
07:20	R	NSF	0000900090940C0C0C0C8C4CC2CAC6CEC1C44F9 FFFFFFFFFFFFFFFF80E28041800C	L , I D	A
07:20	R	CSI	2020202020202020202020202020202020323239		229
07:21	R	DIS	00000000 01110111 00011001 00100011 001 00001011 11000001 00000001	W #	

(2) TOTAL ERRORS

This list is printed out with a title of ERROR COUNT LIST. It indicates the history of errors to check for errors attributable to the line conditions.

Print Items

- TRANSMISSION/RECEPTION Indicates whether the error is on the sending side or on the receiving side.
- STATUS HISTORY Prints the error codes in the ascending order.  
Prints the history of errors moved from the actual side by "occurred error count / communication count."  
The time when moved to the history side is printed in the time print field (top line).
- ACTUAL Prints the present error occurred status by "occurred error count / communication count." The time when counting is started is printed in the time print field (top line). When the communication count reaches 1000 on the actual side, the error occurred status is automatically moved to and added to the history side and the actual side is cleared.  
Even if the communication count has not reached 1000, if error counter shift is executed, the counts up to the present will be moved from the actual side to the history side.

ERROR COUNT LIST			
		PAGE : 001	XXXXXXXXXX XXXXXXXXXXXX XXXXXXXXXX XXXXX
		TIME : NOV-15-00 04:09PM	
		TEL NUMBER : 12345678901234567890	
		E-MAIL : ABCDEFGHIJKLMNOPQRSTUVWXYZ12345678901234	
		NAME : ABCDEFGHIJKLMNOPQRSTUVWXYZABCDEFGHIJKLMN	
TRANSMISSION	STATUS	HISTORY	CURRENT COUNTER
		NOV-15-00 10:57AM - NOV-12-00 08:13AM	NOV-12-00 09:22AM -
	00	0918 / 1000	0102 / 0119
		0000 / 1000	0000 / 0119
		/ 1000	0000 / 0119
			0000 / 0119

(3) FUNCTION (FUNC, 05, 08 List)

This list is printed out with a title of SETTING REPORT FOR MAINTENANCE. It prints a list of present function settings.

Print Items

• 1st Sheet

COUNTRY	Country code
FUNC 0 to 39	Prints the settings at this point of time in binary format.
PC FUNC 0 to 7	↓
HOME 0 to 2	↓
UAD 0 to 19	↓
EX TYPE 1	↓
ACC DGT 1 to 2	↓

• 2nd Sheet

05 xxx	Prints the set values at this point of time.
08 xxx	↓
(xxx is code number.)	

XXXXXXXXXX XXXXXXXXXXXX  
XXXXXXXXXX XXXXX

## FUNCTION LIST FOR MAINTENANCE

PAGE : 001  
TIME : NOV-15-00 04:09PM

COUNTRY		0001				
FUNC	0	10101101	AD	HOME	0	00000010 02
FUNC	1	10100011	A3	HOME	1	00000000 00
FUNC	2	10000110	86	HOME	2	00000001 01
FUNC	3	01011000	58	UAD	0	00101110 2E
FUNC	4	10101010	AA	UAD	1	01010001 51
FUNC	5	01011011	5B	UAD	2	00101110 2E
				UAD	3	01101001 69
				UAD	4	00001011 00



(4) DRUM HISTORY

Refer to page 1-45 of Service Handbook (DP1600/2000/2500).

(5) MEMORY DUMP

Refer to page 1-46 of Service Handbook (DP1600/2000/2500).

## 1.2.6 Country code

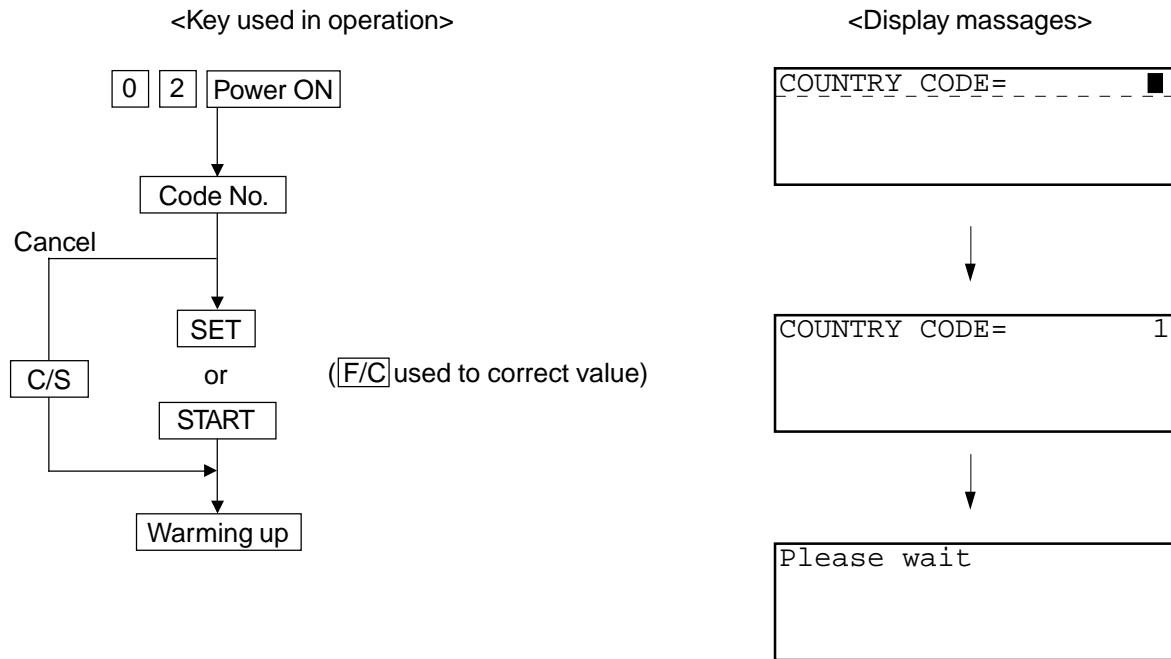

Country/Region	Code	Country/Region	Code
United States	US 1	Ireland	IE 353
Canada	CA 9999	Singapore/Saudi Arabia	SG/SA 65
Germany	DE 49	Hong Kong	HK 852
United Kingdom	GB 44	Australia/New Zealand	AU/NZ 61
Italy	IT 39	France	FR 33
Sweden	SE 46	Latin America (LT)	LA1 55
Norway	NO 47	Latin America (A4)	LA2 9998
Denmark	DK 45	Russia	RU 7
Switzerland	CH 41	Poland	PL 48
Finland	FI 358	Hungary	HU 36
Netherlands	NL 31	Czech Republic	CZ 42
Austria	AT 43	Turkey	TR 90
Belgium	BE 32	South Africa	ZA 27
Portugal	PT 351	Taiwan	TW 886
Spain	ES 34	China	CN 86
Greece	GR 30		

## 1.3 Remote Service

### 1.3.1 RDC (Remote Diagnosis Configuration) Service

#### (1) Remote Access

The remote access function allows checking of the copier conditions, and enabling the function for changing setting data of the copier and the firmware that controls the copier, on a remote basis, via communication.

To enable the remote access function, be sure to follow the setting procedure described below.

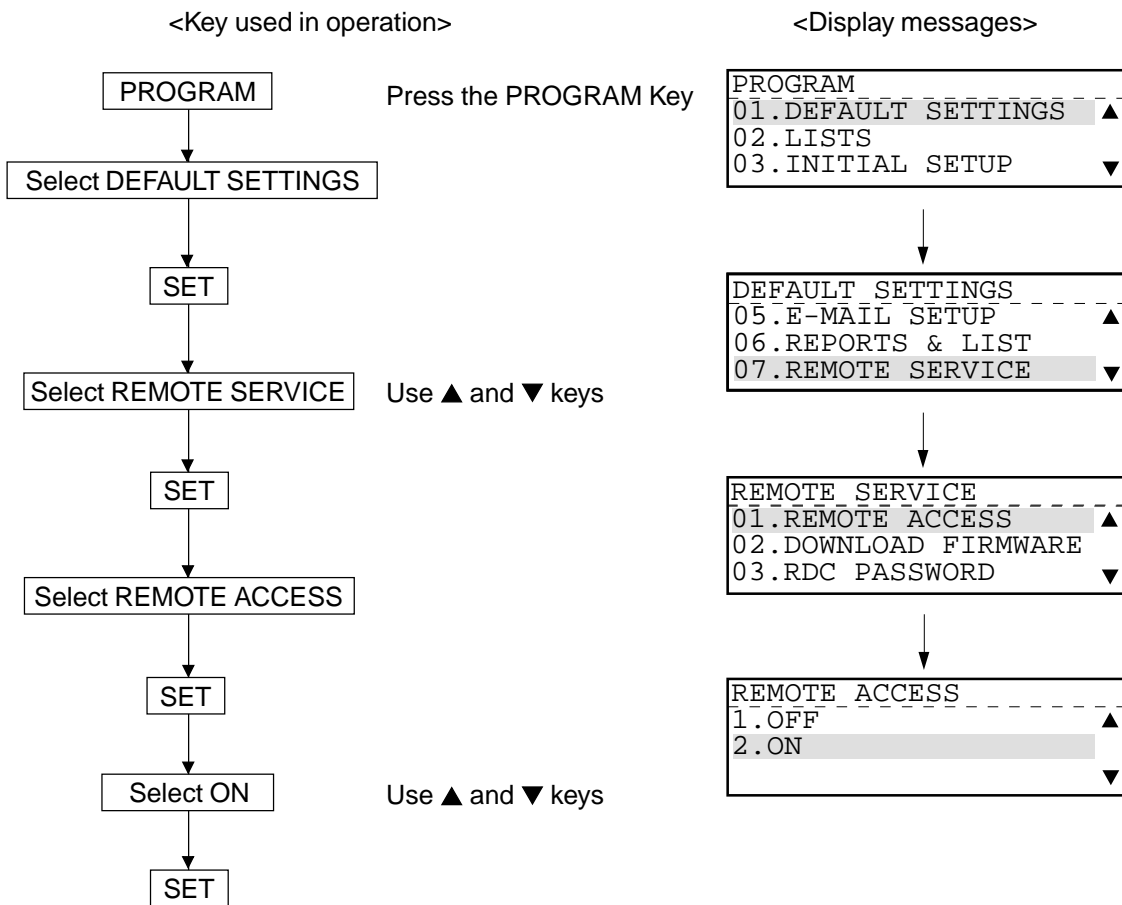

**Note:** When OFF is selected for Remote Access, accesses through RDC cannot be made. Requests for uploading and downloading the phonebook, retrieving the list, downloading programs, and automatic accesses, over the line, are rejected. However, this setting does not have influence on accesses through LDC or the network.

## (2) Downloading Firmware

The firmware that controls the copier, language information and function setting information can be upgraded over the line via the network, from the RDC Center. Either of the following two conditions can be selected:

- NO JOB IN MEMORY: Possible when there is no reserved fax job.
- ANYTIME: Always possible.

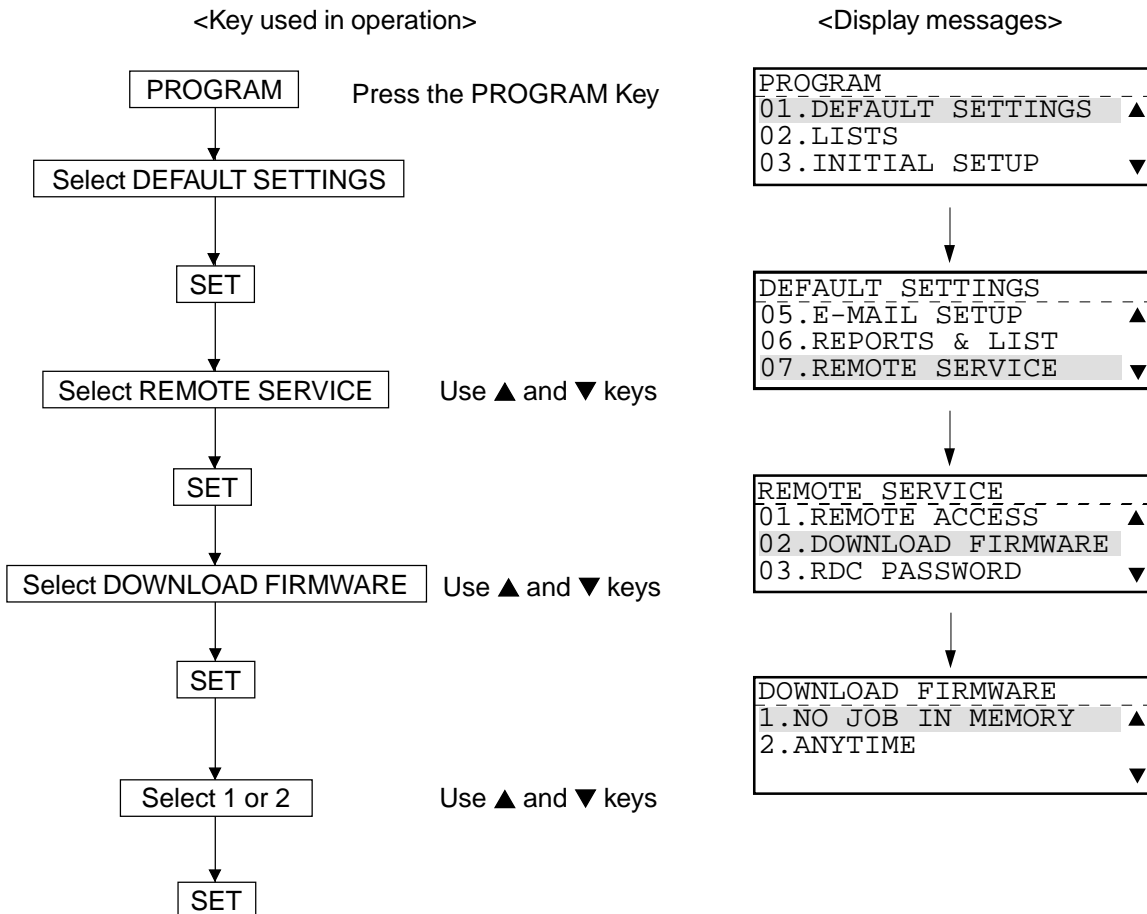

**Note:** If ANYTIME is selected when there are reserved fax jobs, firmware downloading will delete all the fax jobs.

After the copier is rebooted by turning it off then on, after downloading the firmware, the copier will be controlled with downloaded data.

### (3) RDC Password

To access the copier through RDC, the security password (Max. 20 digits) is required for protecting the setting data of the copier. Only when the password coincides with the password that was registered with the RDC Center, during an access from the RDC Center to the copier according to the RDC protocol, operations through RDC are enabled.

When the passwords do not coincide, the communication is cut off. This password is also called TSI Security Password.

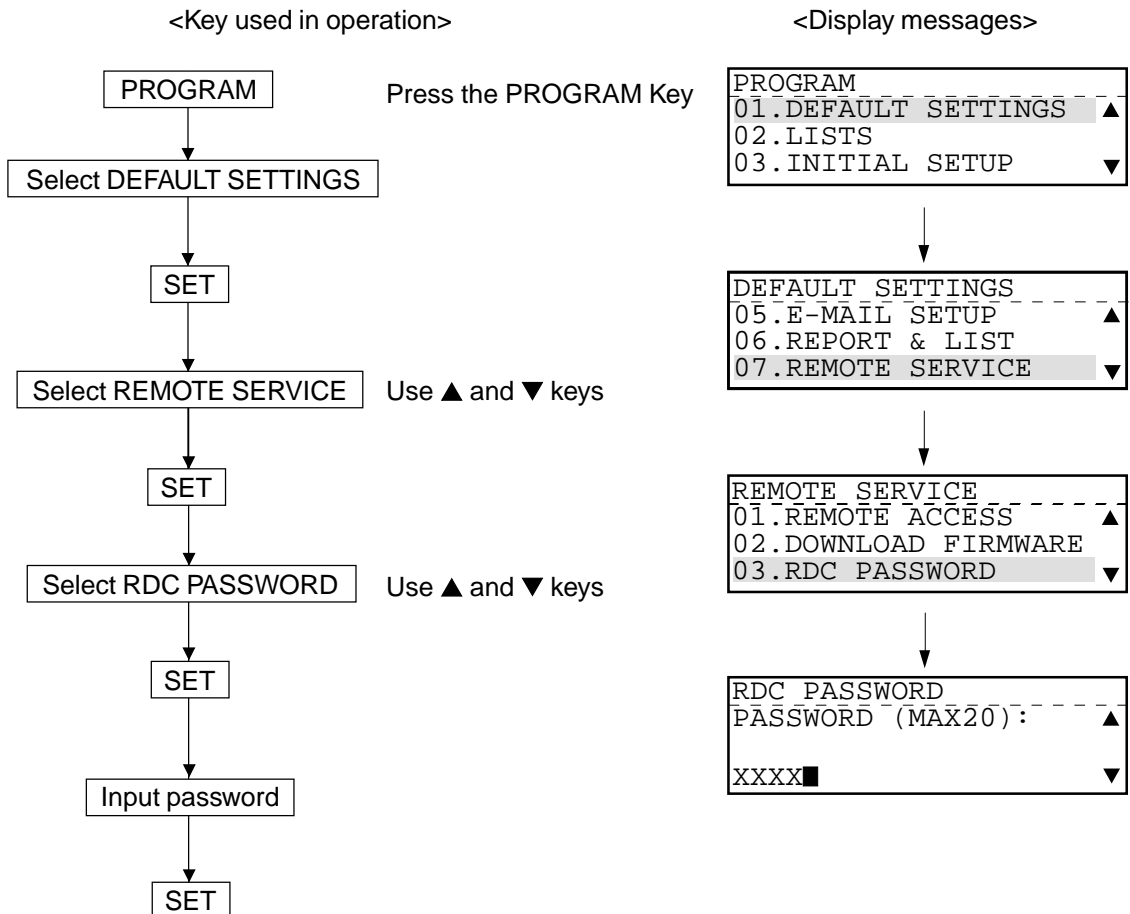

**Note:** When an access through RDC is attempted without setting the password on the copier, the communication will be cut off. The keys used for setting the password are numeric keys from 0 to 9 and the SPACE key.

### 1.3.2 Automatic Supplies Order

The function automatically notifies the supplies vendor of the replacement time for the toner pack and the process unit.

By entering the following items, you can automatically place an order of the registered quantity of the toner pack or the process unit, after the registered quantity is used up.

Items to be set:

- a. Vendor to which the supplies list is sent (telephone number or email address)
- b. Quantity of toner pack/process unit to be ordered (1 to 99)
- c. Part number for toner pack/process unit (Max. 20 digits)
- d. Customer number (Max. 20 digits)
- e. Contact name (Max. 40 digits)
- f. Telephone person (Max. 32 digits)
- g. Customer to whom the supplies are sent (Max. 40 digits)
- h. Address to which the supplies are sent (Max. 64 digits)

The procedure for programming each items is described below.

On this page, the procedure that is common to all the programming procedures (up to A) is described. On the subsequent pages, the procedures for programming each item, after A. are described.

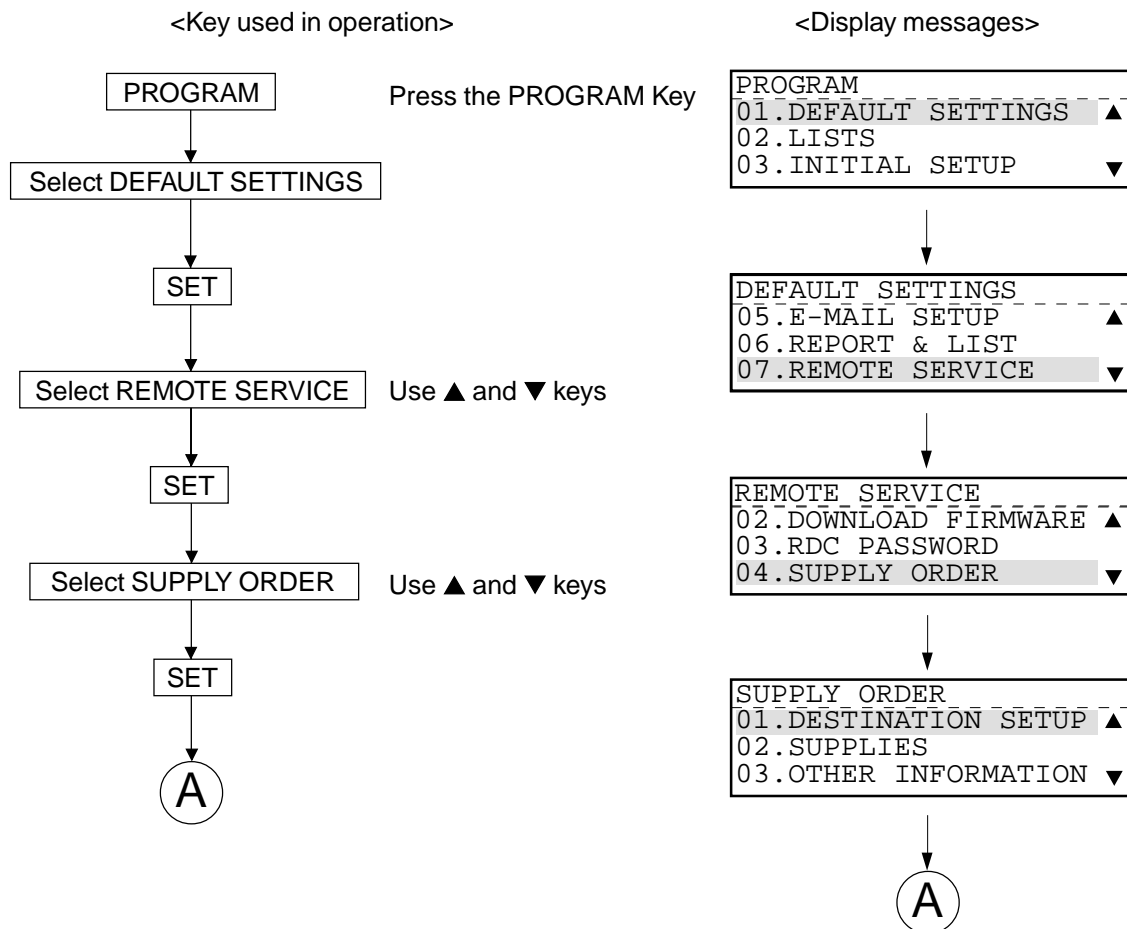

1) Vendor to which the supplies list is sent (telephone number or email address): DESTINATION SETUP

<Key used in operation>

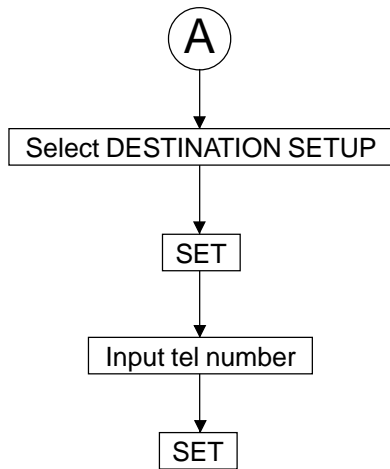

<Display messages>

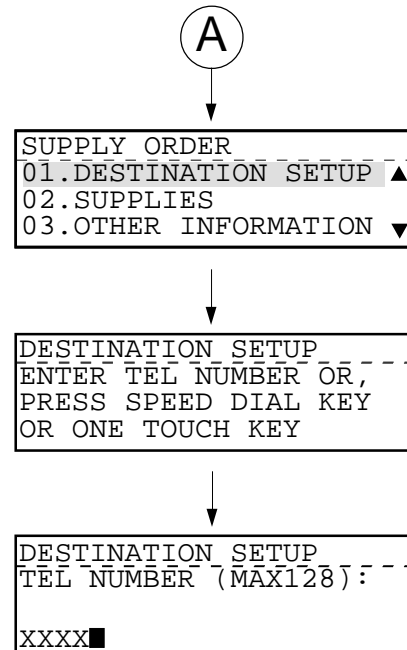

- 2) Quantity of toner pack/process unit to be ordered (1 to 99): ENTER QUANTITY
- 3) Part number for toner pack/process unit (Max. 20 digits): ENTER PART NUMBER

Enter the part number and the order quantity for the toner pack and the process unit individually.  
The procedure and the screen display are the same after selecting 01.TONER/02.DRUM.

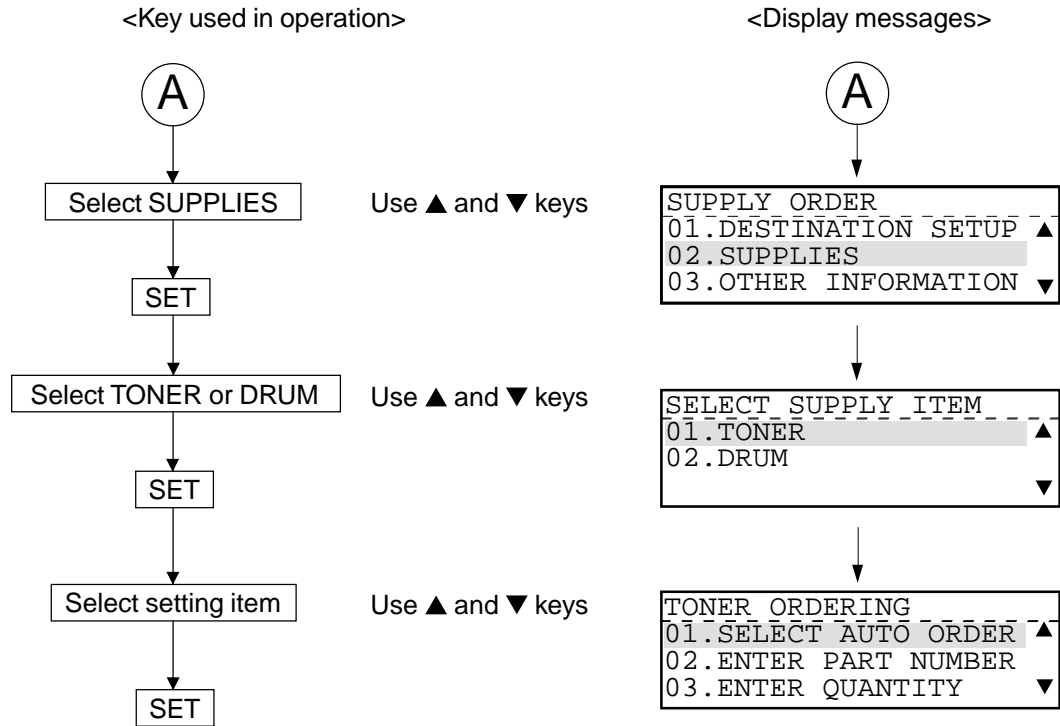

- When 01.SELECT AUTO ORDER is selected, the screen prompts you to select 1.YES or 2.NO. If you do not select 1.YES, the automatic supplies order is not enabled.
- 02.ENTER PART NUMBER is selected to enter the part number for the supplies.
- 03.ENTER QUANTITY is selected to enter the order quantity of the supplies.



- 4) Customer number (Max. 20 digits): CUSTOMER NUMBER
- 5) Contact person (Max. 40 digits): CONTACT NAME
- 6) Telephone number (Max. 32 digits): CONTACT TEL NUMBER
- 7) Customer to whom the supplies are sent (Max. 40 digits): SHIP TO NAME
- 8) Address to which the supplies are sent (Max. 64 digits): SHIP TO ADDRESS

Setups of 4) to 8) are performed after selecting 03: OTHER INFORMATION.

<Key used in operation>

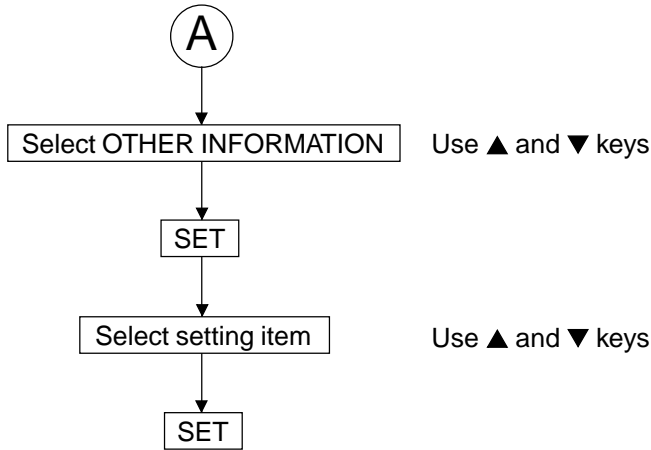

<Display messages>

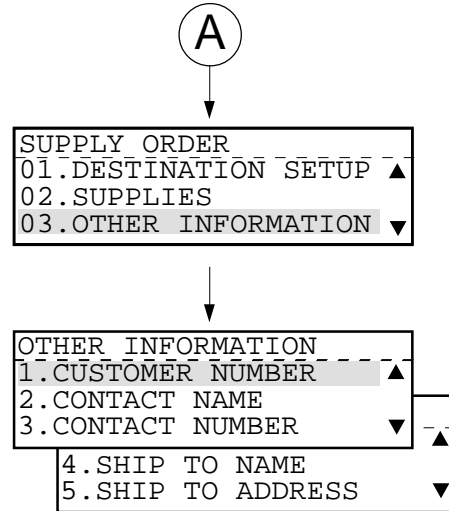

## 2. TROUBLESHOOTING

### 2.1 Diagnosis Over Telephone

Most problems end user inquiries are a result of the following. Therefore, first ask the nature of the trouble (in detail) to seek the cause. These questions can lead to a speedy resolution of the trouble without the need for a service technician.

- **Simple misoperation**

A trouble caused by a simple misoperation can be solved by the user alone with an appropriate instruction through the telephone.

- **A failure with the telephone line**

The machine's condition can be checked by the user's operating sending/receiving documents to/from another facsimile unit.

- **A failure with the other party's machine**

The other party's machine's condition can be checked by the user's operating sending/receiving documents from/to the user's machine.

Also, by verifying the error message in the LCD display or the error code on the Journal with the user, the nature of the trouble can be confirmed. This information is important in finding the cause of trouble. Whenever it can be obtained from the user, respond on the telephone by tracing the "2.4 Recommended Flow Chart for Telephone Diagnosis." This will help the service technician to be prepared for the necessary service requirements.

## 2.2 Recommended Flow Chart for Field Service

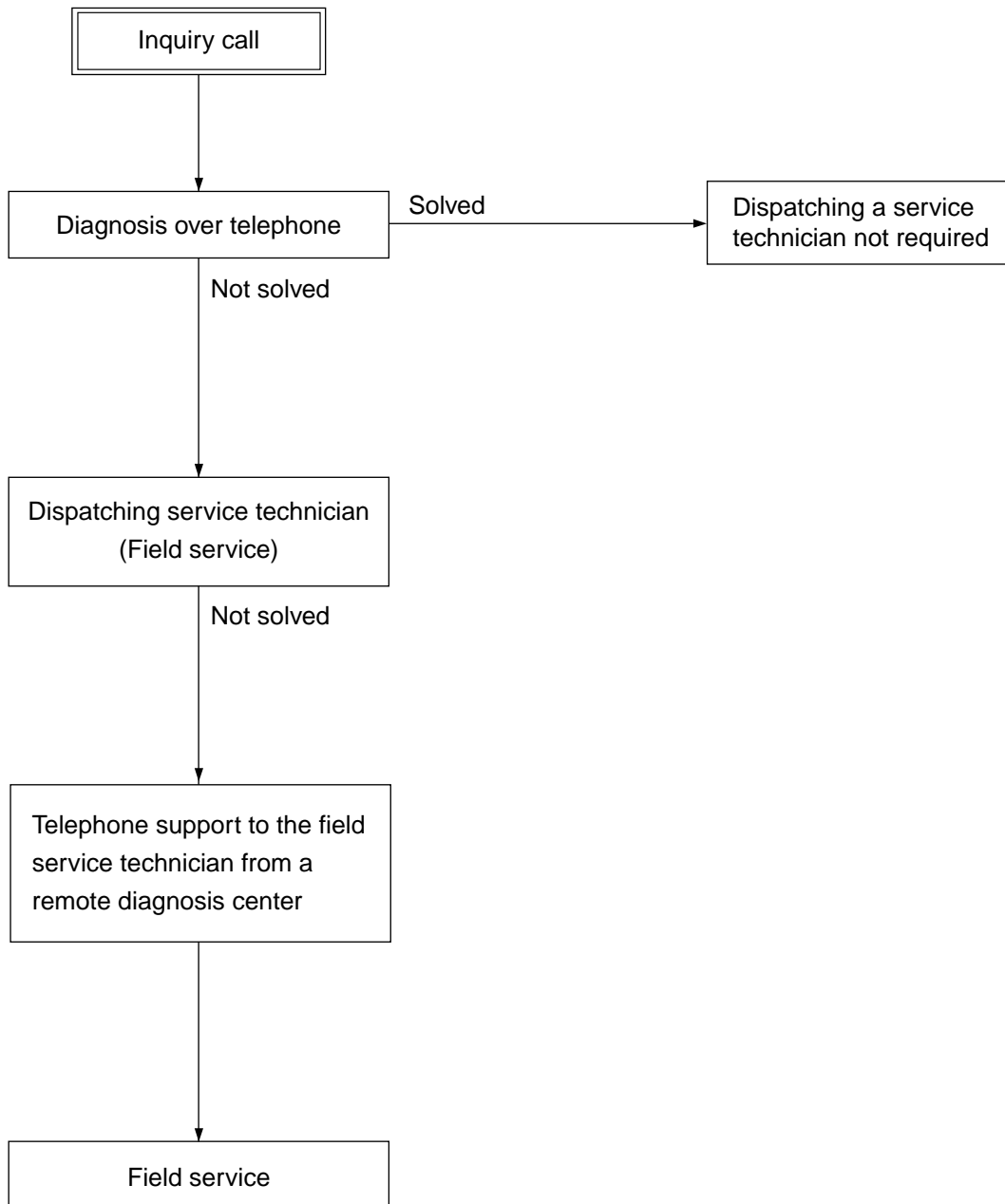

## 2.3 Recommended Flow Chart for Telephone Diagnosis

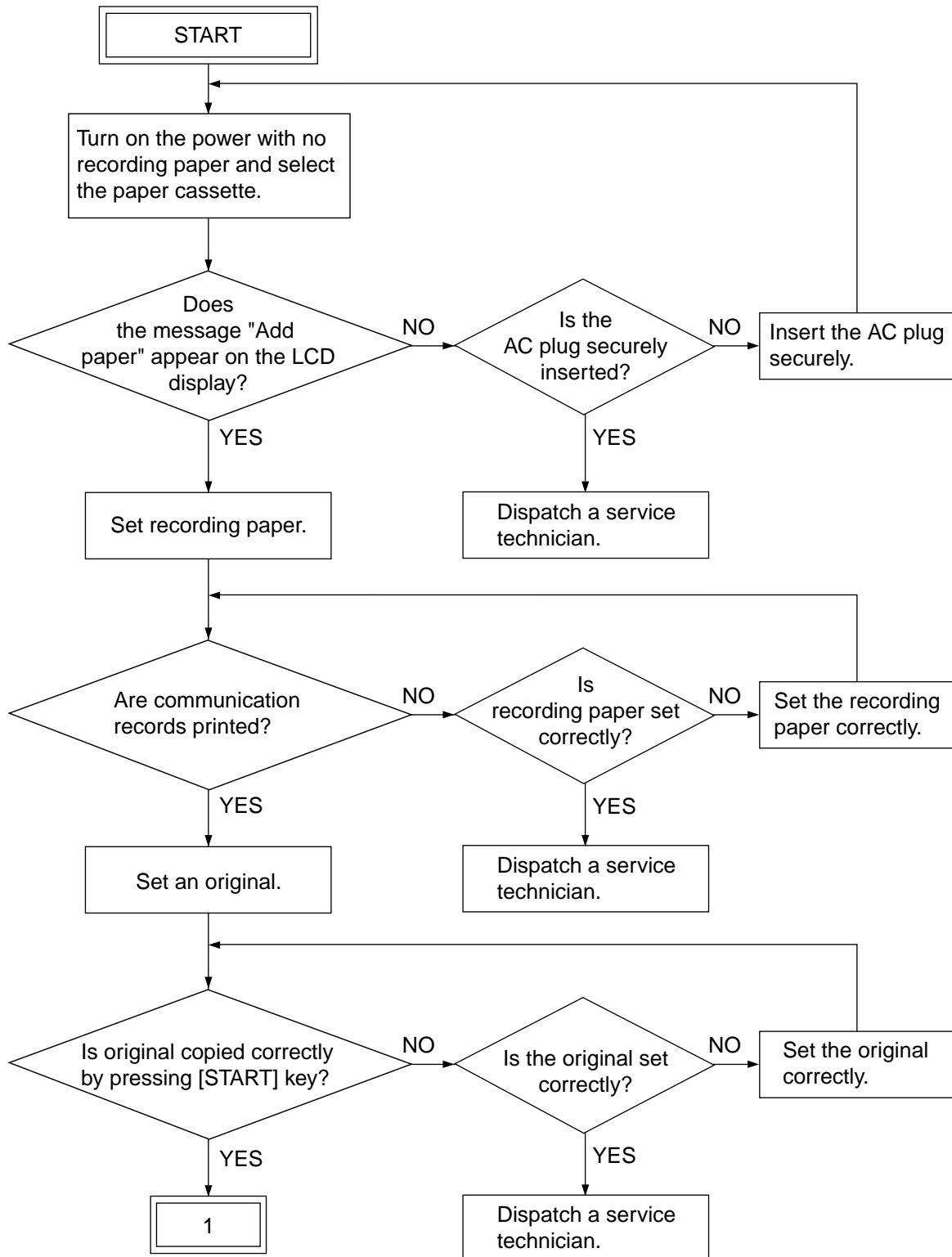

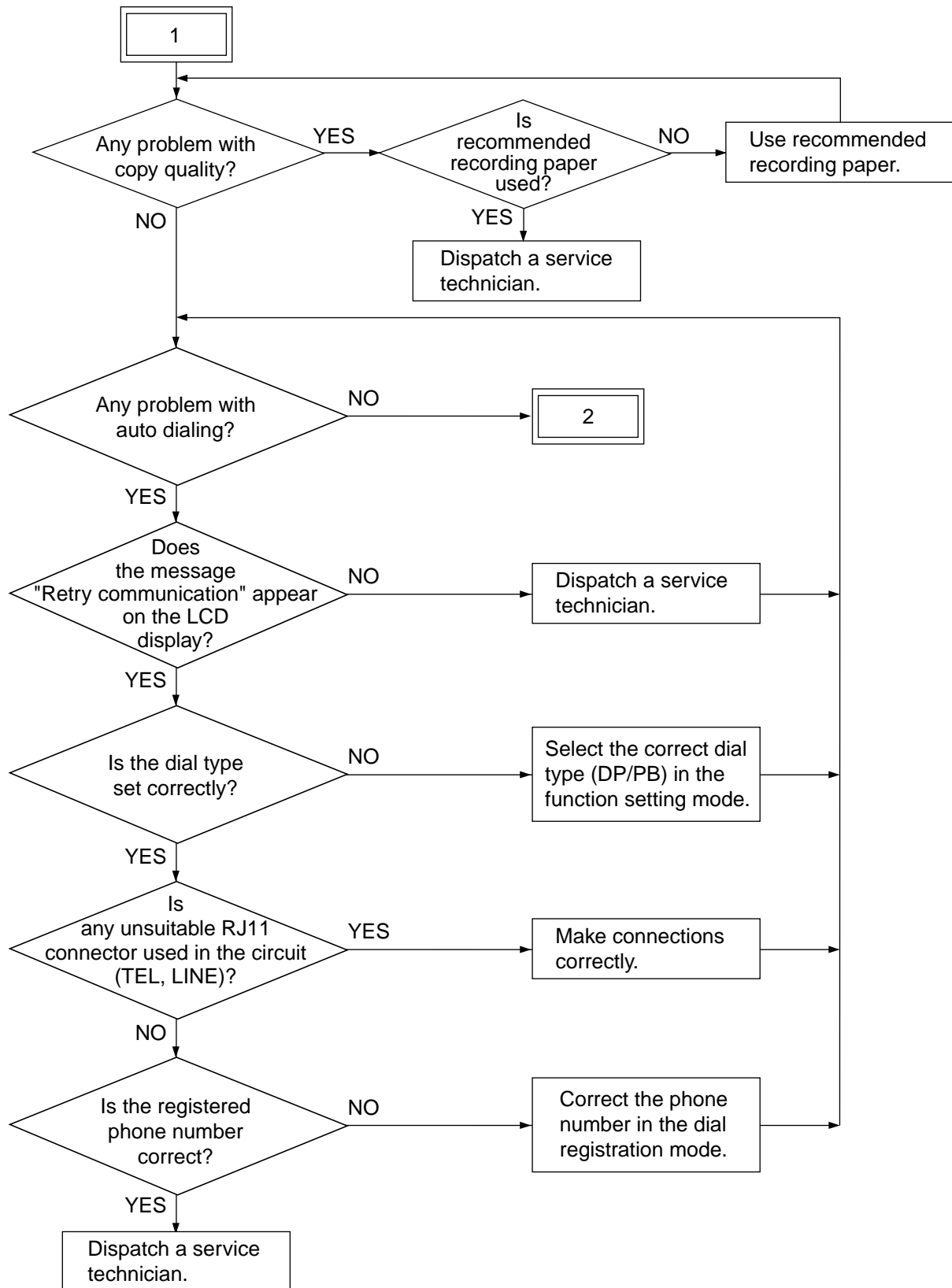

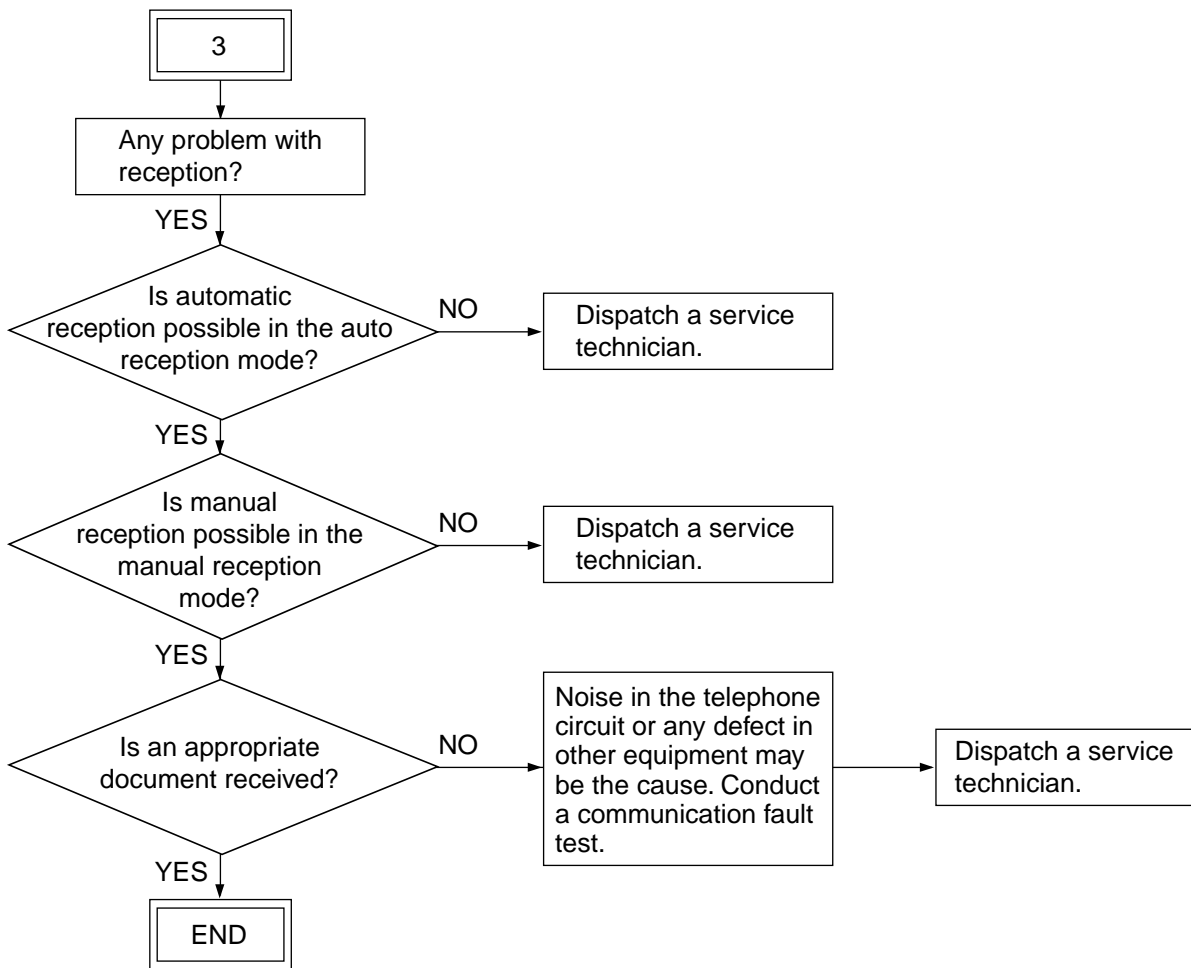
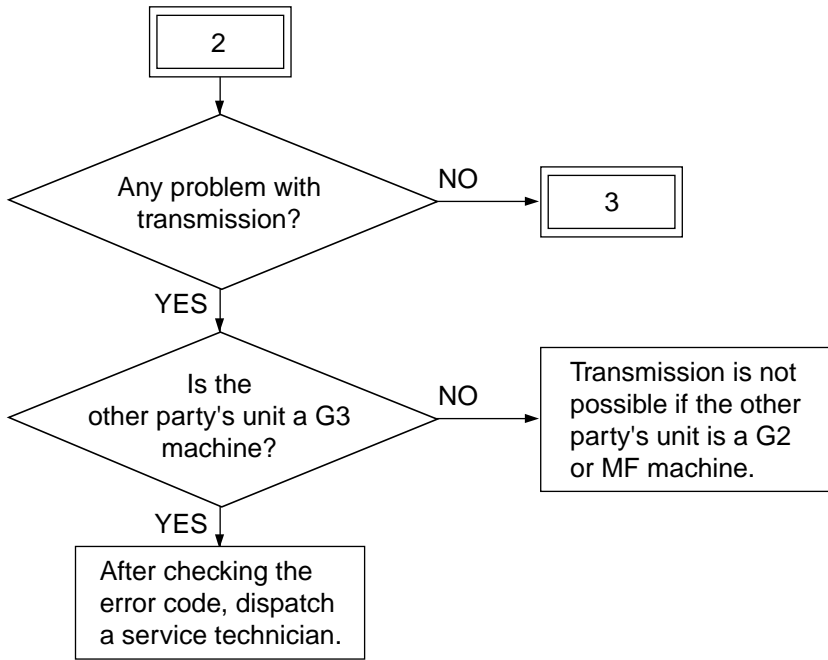

## 2.4 Fault Analysis Flow

### 2.4.1 Self-diagnostic function

The service technician can clearly grasp the contents of faults by the following means:

- 1) Indication on the LCD display
- 2) Error code indication in the communication management record

### 2.4.2 Before starting diagnosis

Before starting diagnosis, the service technician should set recording paper and produces a dial list and system setting list. Check that no received document data is stored in memory.

Before starting diagnosis, turn off the power and check the following items:

- 1) Is the power cord plug inserted correctly?
- 2) Are all connectors connected securely?

**Notes :** When replacing parts, confirm that the amount of memory left is 100% and that there is no memory reception document. Then, turn off the power switch and pull out the power cord plug to start work.

Do not touch the terminal part of any connector, otherwise, a poor connection may result.

## **2.5 Fault Analysis**

### **2.5.1 Power-ON is not possible**

1. Check if the power-cord plug is plugged into an appropriate outlet (of the correct voltage).
2. Check if the rated voltages are being output from the LVPS. When the measured voltage is not the rated value, replace the LVPS.
3. Check if each connector between the operation panel PCB (CN60) and the main PCB (CN9) is disconnected.
4. Check if each connector between the main PCB (CN15) and the relay PCB (CN21) is disconnected.
5. Check if each connector between the relay PCB (CN60) and the LVPS (CN6) is disconnected.
6. Check if each connector pin is removed or the harness is broken.
7. Check if any conductor pattern on the LVPS, relay and main PCB is open- or short-circuited.
8. Replace the operation panel PCB.
9. Replace the relay PCB.
10. Replace the main PCB.

### **2.5.2 Document feed error for ADF/RADF**

Check the error code and refer to the troubleshooting of service handbook for copier.

### **2.5.3 Recording paper feed error**

Check the error code and refer to the troubleshooting of service handbook for copier.

### **2.5.4 Poor print quality**

Check the image and refer to the troubleshooting of service handbook for copier.



### 2.5.5 Communication error

Communication errors may occur when the condition of a particular phone circuit happens to be bad at the time of attempting the communication job. Therefore, do the communication over again. If communication errors occur too many times, prepare another (known good) facsimile unit and check the communication condition among the three facsimile units, thus analyzing the troubles.

A communication error occurs between A and B.

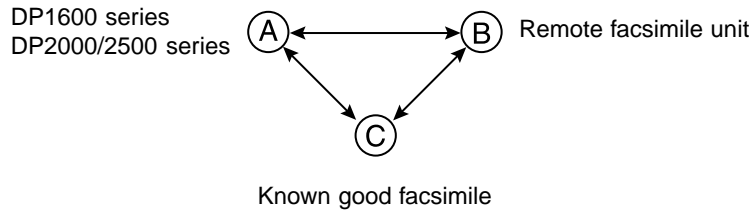

1. If normal communications are possible between A and C, and the communication trouble occurs B and C, it can be assumed that B facsimile is malfunctioning.
2. If normal communications are possible between B and C, and the communication trouble occurs A and C, it can be assumed that A facsimile is malfunctioning. Therefore, adjust the transmission attenuator value (FUNC4 & 28) and the cable equalizer value (FUNC5).
3. If normal communications are possible between A and C and between B and C, it can be assumed that there is a problem in the line between A and B. Ask the applicable organization (telephone company, etc.) to check the telephone line.

### 3. REQUESTED LIST WHEN FIELD PROBLEMS OCCUR

#### 3.1 Requested Lists

The following lists are requested when a fax-related problem occurs.

They are arranged in the order of priority with the most important at the top.

Be sure to get them any time, if not immediately after, a problem has occurred.

No. / Item	List type
1	Protocol Trace List
2	Error Count List
3	Function List for Maintenance
4	Memory Dump List

\* For the listing procedure, refer to the next page.

**Note:** Input the address and the size using the digital keys as bellow.

Input	Digital Keys
0	0
1	1
2	2
3	3
4	4
5	5
6	6
7	7
8	8
9	9
A	*0
B	*1
C	*2
D	*3
E	*4
F	*5

(1)

READY	1
PAPER :APS	C/D :AUTO
FINISHING:SORT	ZOOM:100%
EDIT ▼	

[PROGRAM]

(2)

PROGRAM
01.DEFAULT SETTINGS ▲
02.LISTS
03.INITIAL SETUP ▼

[\*][#][\*][\*]

[\*][#][\*][\*]

(3)

***SERVICE MODE***
01.DEFAULT SETTINGS ▲
02.LISTS
03.INITIAL SETUP ▼

▼ x4

(4)

***SERVICE MODE***
03.INITIAL SETUP ▲
04.MENU LIST
05.TEST MODE ▼

[SET]

[CANCEL]

(5)

TEST MODE
01.AUTO TEST ▲
02.INDIVIDUAL TEST
03.TEST RESULT LIST ▼

▼ x5

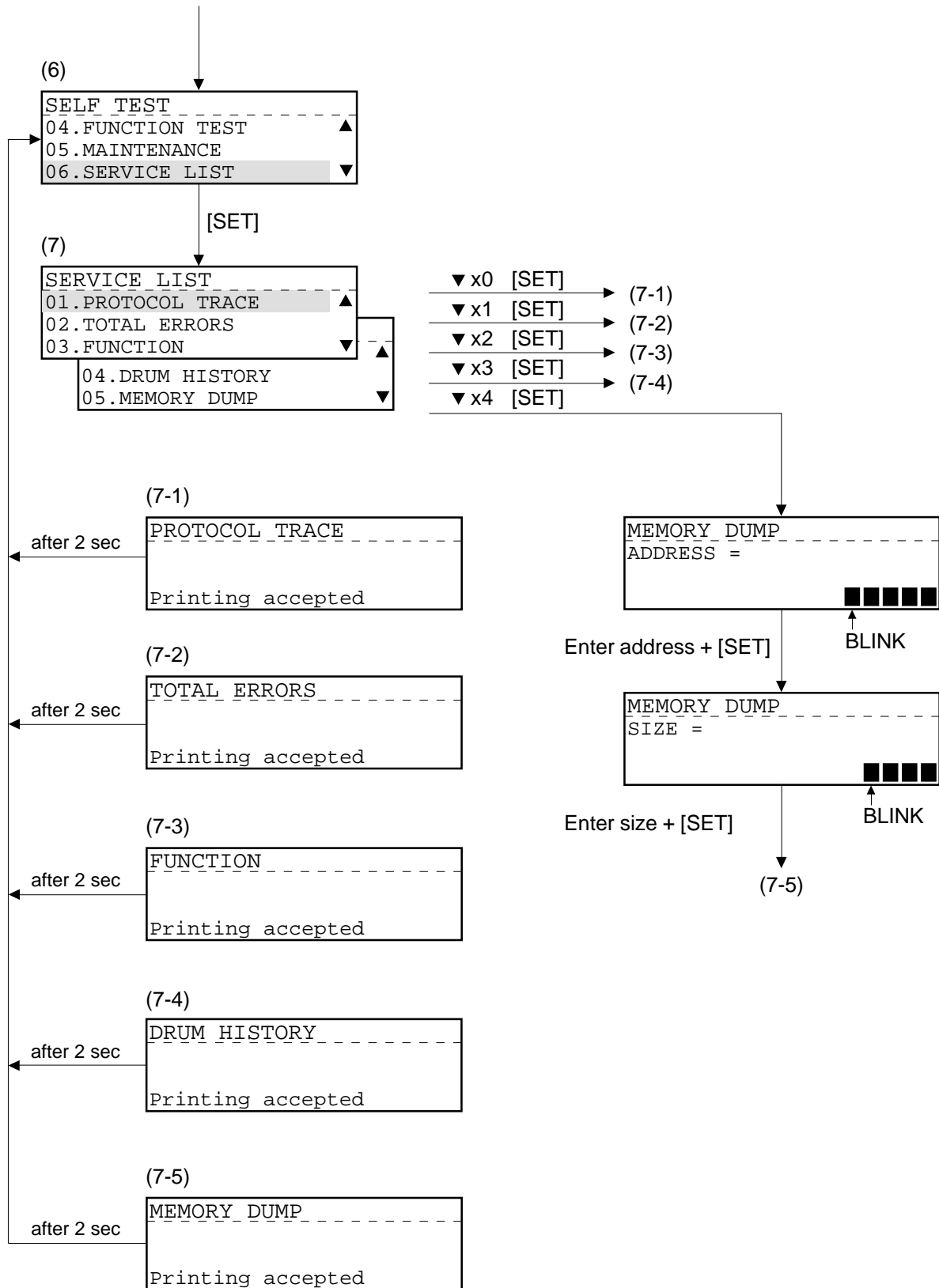

**[Precautions for acquiring the lists]**

When a problem has occurred, first pull out the telephone line to disable communication. Since the protocol trace is listed only for one session of communication immediately before, if the telephone line is not pulled out, a different communication may come in to overwrite the list before it is acquired. Lists (1) and (2) should be obtained without turning off the power switch of the machine, otherwise, the information will be erased.

(1) Protocol Trace List

Fax protocols for one session of communication when the problem has occurred is acquired.

PROTOCOL TRACE LIST				XXXXXXXXXX XXXXXXXXXXXX
				XXXXXXXXXX XXXXX
		PAGE	: 001	
		TIME	: NOV-15-00 04:09PM	
		TEL NUMBER	: 12345678901234567890	
		E-MAIL	: ABCDEFGHIJKLMNOPQRSTUVWXYZ12345678901234	
		NAME	: ABCDEFGHIJKLMNOPQRSTUVWXYZABCDEFGHIJKLMN	
TIME	SEND/RCV	FCF DATA	FIF DATA	ASCII
07:20	R	NSF	0000900090940C0C0C0C8C4CCC2CAG6CEC1C44F9 FFFFFFFFFFFFFFFF80E28041800C	L , I D A
07:20	R	CSI	202020202020202020202020202020202020323239	229
07:21	R	DIS	00000000 01110111 00011001 00100011 001 00001011 11000001 00000001	W #

(2) Memory Dump List

You can check the contents of the memory at the address you have specified.

MEMORY DUMP LIST				XXXXXXXXXX XXXXXXXXXXXX
				XXXXXXXXXX XXXXX
		PAGE	: 001	
		TIME	: NOV-15-00 04:09PM	
		TEL NUMBER	: 12345678901234567890	
		E-MAIL	: ABCDEFGHIJKLMNOPQRSTUVWXYZ12345678901234	
		NAME	: ABCDEFGHIJKLMNOPQRSTUVWXYZABCDEFGHIJKLMN	
ADDRESS	HEX DATA	ASCII		
000D00	319464BE75DB3FB3 2598EDDC2465B25D	1 u ? % \$e ]		
000D10	A82AB741A19C80C7 BF8B254964494884	* A %ldIH		
000D20	65BF5591B3418ECD 9A0CBEF3B07CB8D8	e U A .		
000D30	00E4BD1D383B	[ _z  1 · 8;		
		vI S% n; b		

(3) Errors Count List

A management aggregate list of fax communication errors is acquired. It allows you to check if a particular error is recurring.

ERROR COUNT LIST			
XXXXXXXXXX XXXXXXXXXXXX XXXXXXXXXX XXXXX			
PAGE : 001			
TIME : NOV-15-00 04:09PM			
TEL NUMBER : 12345678901234567890			
E-MAIL : ABCDEFGHIJKLMNOPQRSTUVWXYZ12345678901234			
NAME : ABCDEFGHIJKLMNOPQRSTUVWXYZABCDEFGHIJKLMN			
TRANSMISSION	STATUS	HISTORY	CURRENT COUNTER
		2000-NOV-15 10:57 - 2001-MAR-24 20:13	2000-NOV-21 09:22 -
	00	0918 / 1000	0102 / 0119
	00	0000 / 1000	0000 / 0119
	00	0000 / 1000	0000 / 0119
	00	0000 / 1000	0000 / 0119

(4) Function List for Maintenance

This report lists the set statuses of various functions that can be programmed by service personnel.

FUNCTION LIST FOR MAINTENANCE			
XXXXXXXXXX XXXXXXXXXXXX XXXXXXXXXX XXXXX			
PAGE : 001			
TIME : NOV-15-00 04:09PM			
COUNTRY	0001		
FUNC 0	10101101 AD	HOME 0	00000010 02
FUNC 1	10100011 A3	HOME 1	00000000 00
FUNC 2	10000110 86	HOME 2	00000001 01
FUNC 3	01011000 58	UAD 0	00101110 2E
FUNC 4	10101010 AA	UAD 1	01010001 51
FUNC 5	01011011 5B	UAD 2	00101110 2E
		UAD 3	01101001 69
		UAD 4	00001011 00

(5) Transmission Journal

A transmission record for 150 communication sessions is listed. Check it for communication NG occurrence statuses, based on the communication time, error codes, etc. Also, check if communication fails only with a particular party.

TRANSMISSION JOURNAL										
					PAGE	:	001			
					TIME	:	NOV-15-00 04:09PM			
					TEL NUMBER	:	12345678901234567890			
					E-MAIL	:	ABCDEFGHIJKLMNOPQRSTUVWXYZ12345678901234			
					NAME	:	ABCDEFGHIJKLMNOPQRSTUVWXYZABCDEFGHIJKLMN			
					SCAN COUNT	:	67	(00000043)		
					PRINT COUNT	:	97	(00000061)		
					DRUM COUNT	:	970	(000003CA)		
NBR	FILENBR	DATE TIME	DURATION	PGS	TO	DEPT	ACCOUNT	MODE	STATUS	
001	001	NOV-15 12:00AM	00/41	001	12345678901234567890	D 01	9999	G3 330 P	OK	30
002	010	NOV-16 11:10AM	03/47	006	123456			EC 503 P	OK	
003	011	NOV-18 01:14PM	00/24	000	0559891024	D 08		EX 512 R	NG	DO
004	012			012	<>03123456	D 20	2000	HS 111 B	OK	
					001020			EC 602 SB	NG	

(6) Reception Journal

A reception record for 150 communication sessions is listed. Check it for communication NG occurrence statuses, based on the communication time, error codes, etc. Also, check if communication fails only with a particular party.

RECEPTION JOURNAL										
					PAGE	:	001			
					TIME	:	NOV-15-00 04:09PM			
					TEL NUMBER	:	12345678901234567890			
					E-MAIL	:	ABCDEFGHIJKLMNOPQRSTUVWXYZ12345678901234			
					NAME	:	ABCDEFGHIJKLMNOPQRSTUVWXYZABCDEFGHIJKLMN			
					SCAN COUNT	:	67	(00000043)		
					PRINT COUNT	:	97	(00000061)		
					DRUM COUNT	:	970	(000003CA)		
NBR	FILENBR	DATE TIME	DURATION	PGS	FROM	DEPT	ACCOUNT	MODE	STATUS	
001	001	NOV-25 12:00AM	00/41	001	12345678901234567890	D 01	9999	G3 330 P	OK	30
002	010	NOV-26 11:10AM	03/47	006	s-pulse@football.co.			ML 5 3	OK	
003	011	NOV-28 01:14PM	00/24	000	123123456123			EX 512 R	NG	DO
004	012			012	05559se		2000	HS 111 B	OK	
					123456789012			EC 602 SB	NG	

(7) Function List

This list prints out the set statuses of various functions which have been programmed by the user.

<b>FUNCTION LIST</b>		XXXXXXXXXX	XXXXXXXXXX
		XXXXXXXXXX	XXXXX
	PAGE	:	001
	TIME	:	NOV-15-00 04:09PM
	TEL NUMBER	:	12345678901234567890
	E-MAIL	:	ABCDEFGHIJKLMNOPQRSTUVWXYZ12345678901234
	NAME	:	ABCDEFGHIJKLMNOPQRSTUVWXYZABCDEFGHIJKLMN
KEYBOARD TYPE	:	QWERTY	
MEMORY SIZE	:	96MB	
		MEMORY RX	: ON
		RX REDUCTION	: ON
		DISCARD	: ON
MACHINE DEFAULTS		PRIVILEGED RX	: ON
CASSETTE SIZE		RTI	: ON



Problem (State as in detail as possible)

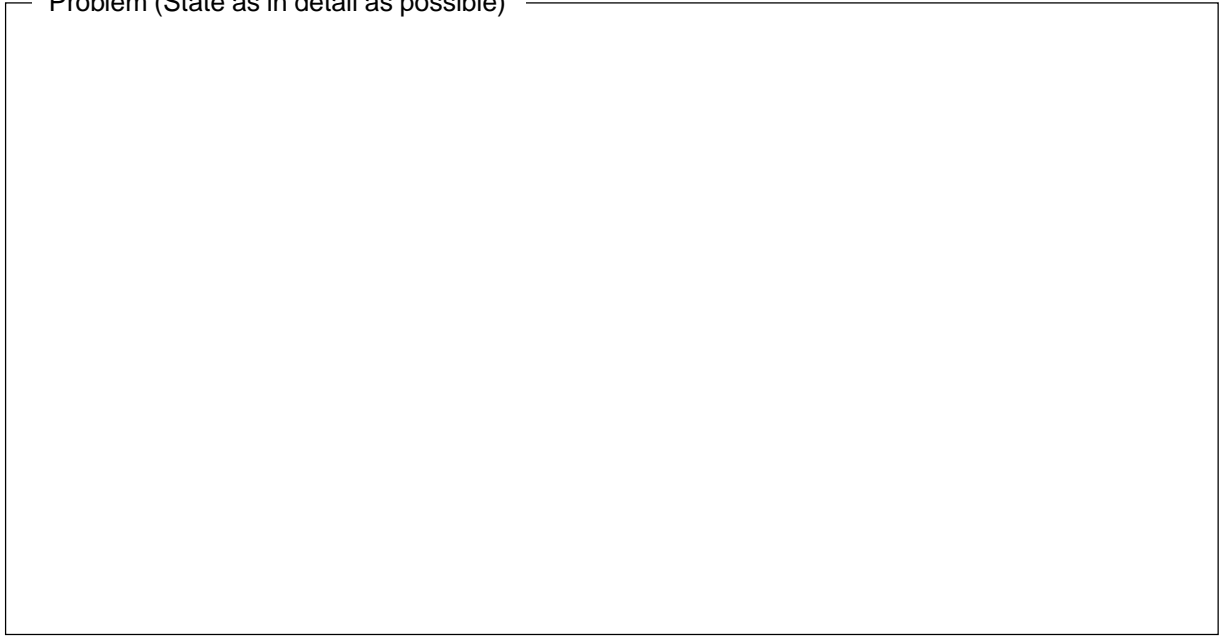

### 3.2 Other Necessary Information

When analyzing a problem (particularly a communication problem), the following information should also be reported.

(1) Check off the appropriate statement to indicate whether the machine resumes or not.

- Resumes when the power is turned off and then on.
- Resumes when the PCB is replaced.
- Fails to resume.

(2) Repeatability

- Frequent occurrence (Occurs everyday or regularly)
- Sometimes (About once a week)
- Once only

(3) In case of a communication problem, turn on the line monitor, check the fax communication with a voice from the speaker, and check off the appropriate statement.

**Note:** When ending the examination, be sure to turn off the line monitor.

- The line has noise.
  - Request the telephone company for examination to see if there is any problem with the state of the line.
- A busy tone is heard from the contacted station in the middle of communication.
  - Check the contacted station for abnormal conditions. If there are no abnormal conditions, check the model name of the contacted station.
- Other (Description of conditions: \_\_\_\_\_ )

(4) State of the machine at the time when the problem has occurred

① Paper loaded state

- |  |  |
|--|--|
| 1st cassette (size =     ) <input type="radio"/> No paper loaded | <input type="radio"/> Paper loaded                                       |
| 2nd cassette (size =     ) <input type="radio"/> Not mounted     | <input type="radio"/> No paper loaded <input type="radio"/> Paper loaded |
| 3rd cassette (size =     ) <input type="radio"/> Not mounted     | <input type="radio"/> No paper loaded <input type="radio"/> Paper loaded |

② State of ADF or RADF (Fill in for transmission)

- The document has been ejected.             Abnormal condition such as document jam
- Other (Be specific: \_\_\_\_\_ )

③ Communication conditions

- Transmission problem
- Reception problem
- ECM mode
- G3 model

Communication fails with a specific contacted station only (Model name of contacted station: \_\_\_\_\_ )

In case communication fails with a specific contacted station only, it is also suspected that the contacted station is at fault or in a busy state (no response) with the memory full without paper. Check the state of the contacted station.

If the contacted station is found to be without any problems, there is a probability of a communication problem with a specific model. Check the model name.

④ Document size: \_\_\_\_\_

Reception size

(For NAD model)

- LD     LG     LT     ST     COM     A4

(For MJD, AUD, ASD, SAD, TWD, CND model)

- A3     A4     A5     B4     B5     FOLIO     LT

Resolution =  STD (8 x 3.85)     Fine (8 x 7.7)     S-Fine (16 x 15.4)

Total number of communication sheets = \_\_\_ sheets, occurrence of NG with \_\_\_ the sheet

⑤ Line connection state

- Directly connected to the public phone line.
- Connected to the private branch exchange.
  - Another terminal is connected in addition to this machine.
  - Check if CI is the standard pattern.  
(Reception may not be started depending on the pattern of CI.)
- Line switching unit
  - Check if the line setting (DP, MF) of the line switching unit matches the line setting of this machine.

Connection state

(Illustrate the number of lead-in public phone lines, exchange through which the line is connected, jointly set-up telephones, modem, etc.)

## **4. PRECAUTIONS TO USE DURING FAX SET-UP AND REPLACEMENT**

### **4.1 When setting up or replacing the Fax/NCU PBA**

- 1) After having set up the copier according to the unpacking instructions of FAX-Kit, the equipment will start up.
- 2) After confirming that the remaining memory M: 100% on the FAX screen, and that the 'COMMUNICATING' or 'SENDING' LCD Display is off or the Fax communication lamp is not blinking, turn off the power.

The Data of substitute memory reception needs to be printed. If this data can not to be printed, it needs to be printed by another Fax to use the PIX Memory Transfer function. Send forcibly the contents to be stored in the PIX memory or Re-send the data again after replacing the Fax/NCU PBA.

- 3) Replace the Fax/NCU PBA on Main PBA.
- 4) Perform clearing the Memory area by [PIX MEMORY].
- 5) For confirming the normal operation start, perform the DRAM test, CODEC test, MODEM test.

#### **4.1.1 PIX Memory Transfer**

**[Program] [\* # \* \*] [05] [05] [05]**

This function is used to send the contents stored in the PIX memory to the designated remote address when some printer problem disables printing of the received document.

Refer the section in 1.2.4 MAINTENANCE for this procedure.

#### **4.1.2 PIX Memory Clear**

**[Program] [\* # \* \*] [05] [05] [01]**

This function is used to initialize data in memory. This procedure must be performed when the Fax/NCU PBA is replaced or installed. Refer the section in 1.2.4 MAINTENANCE for this procedure.

#### **4.1.3 DRAM test, CODEC test, MODEM test**

**[1] [3] [Power ON]**

These tests can be conducted in the function test mode. Refer the section in 1.2.3 Function test for this procedure.