

MCD3880EM

User manual

Microwave Oven

Thank you for choosing one of our high-quality products.

To ensure optimal and regular performance of your appliance please read this instruction manual carefully. It will enable you to navigate all processes perfectly and most efficiently. To refer to this manual any time you need to, we recommend you to keep it in a safe place. And please pass it to any future owner of the appliance.

We wish you much joy with your new appliance.

Contents

Safety information	2	Automatic function F1 (heating food)	15
General safety	2	Automatic function F2 (cooking)	16
Child safety	4	Automatic function F3 (defrosting and toasting)	17
Utensil safety	4	Hints and tips	18
Food safety	6	Something not working	21
Safety instructions when cooking with grill and combination modes	7	Replace the light bulb	22
Before first use	7	Maintenance and cleaning	22
How a microwave oven works	8	Oven ceiling	23
Description of functions	9	Environmental information	24
Altering parameters	10	Installation	24
Product description	11	Before installation	24
Operation	12	After installation	25
Setting the clock	12	Installation diagrams	26
Child lock	13	Technical data	26
Cooking with microwave	13	Guarantee/Customer Service	27
Quick start	13	GREAT BRITAIN & IRELAND	27
Cooking with grill	14	European Guarantee	28
Cooking with microwave + grill	14	www.electrolux.com	29
Automatic defrost	14		
Manual defrost	15		

Subject to change without notice



Safety information

General safety

READ CAREFULLY AND KEEP FOR FUTURE REFERENCE

- The built-in safety interlock switches prevent the microwave oven from operating when the door is open.
- Do not tamper with them, or attempt to operate the oven with the door open as open door operation can result in exposure to microwave energy.
- Do not allow food spills or cleaner residue to accumulate on door sealing surfaces. See the Cleaning and Care section for cleaning instructions.

- It is particularly important that the oven door closes properly and that there is no damage to the: (1) door (warped), (2) hinges and latches (broken or insecure), (3) door seals and sealing surface.

**WARNING!**

If the door, hinges/latches or door seals are damaged, the microwave must not be operated until it has been repaired by a authorized service person.

**WARNING!**

It is hazardous for anyone except factory trained service personnel to service or make adjustments to this oven. Contact your nearest authorised service agent if service should be required.

- Do not remove the outer case, door or control panel at any time. Doing so may cause exposure to extremely high voltage.
- Install or locate this oven only in accordance with 'installation instructions' found in this manual.
- Use the appliance for its intended use as described in this manual. Do not use corrosive chemicals in this appliance. This type of oven is specifically designed to heat, cook, or defrost food. It is not designed for industrial or laboratory use neither for commercial use as this will invalidate the guarantee.
- Do not operate the oven empty. If food or water is not present to absorb the microwave energy, the magnetron tube can be damaged.
- Do not store this appliance outdoors. Do not use this product near water.
- Do not attempt to dry clothing or newspapers in the microwave oven. These items can ignite.
- Do not use the cavity for storage purposes. Do not leave paper products, cooking utensils, or food in the cavity when not in use.
- The temperature of accessible surfaces may be high when the appliance is operating.

**WARNING!**

If smoke is observed, switch off or unplug the appliance and keep the door closed in order to stifle any flames. Never use water.

**WARNING!**

The appliance is not intended for use by children or persons with reduced physical, sensory or mental capabilities, or lack of experience and knowledge, unless they have been given supervision or instruction.

- Do not force the turntable to rotate by hand. This may cause malfunctioning.
- The appliance is not intended to be operated by means of an external timer or separate remote-control system.
- Care should be taken not to obstruct any air vents located on the top, rear, side and bottom of the oven.

**WARNING!**

Do not use this oven for commercial purposes. This oven is made for domestic use only.

Child safety

- This appliance is designed to be operated by adults. Children should be supervised to ensure they do not tamper with the controls or play with the product.
- Keep all packaging materials away from children.

Utensil safety

Microwave function

For the microwave function, keep in mind that microwaves are reflected by metal surfaces. Glass, china, clay, plastic, and paper let microwaves pass.

For this reason, **metal pans and dishes or containers with metal parts or decorations cannot be used in the microwave.** Glass ware and clay with **metallic decoration or content** (e.g. lead crystal) cannot be used in microwave ovens.

The ideal materials for use in microwave ovens are glass, refractory china or clay, or heat resistant plastic. Very thin, fragile glass or china should only be used for short period of times (e.g. heating).

Hot food transmits heat to the dishes which can become very hot. You should, therefore, always use an oven glove!

How to test ovenware you want to use

Put the item you want to use in the oven for 20 seconds at maximum microwave power. After that time, if it is cold and just slightly warm, it is suitable to use. However, if it heats up a lot or causes electric arcing it is not suitable for microwave use.

Grill and Hot air function

In the case of the grill function, the ovenware must be resistant to temperature of at least 300°C.

Plastic dishes are not suitable for use in the grill.

Microwave + grill function

In the microwave + grill function, the ovenware used must be suitable for use in both the microwave and the grill.

Aluminium containers and foil

Pre-cooked food in aluminium containers or in aluminium foil can be put in the microwave if the following aspects are respected:

Keep in mind the manufacturer's recommendations written on the packaging.

- The aluminium containers cannot be more than 3 cm high or come in contact with the cavity walls (minimum distance 3 cm). Any aluminium lid or top must be removed.
- Put the aluminium container directly on top of the turntable plate. If you use the rectangular rack, put the container on a china plate. Never put the container directly on the rectangular rack!
- The cooking time is longer because the microwaves only enter the food from the top. If you have any doubts, it is best to use only dishes suitable for microwave use.
- Aluminium foil can be used to reflect microwaves during the defrosting process. Delicate food, such as poultry or minced meat, can be protected from excessive heat by covering the respective extremities/edges.
- **Important:** aluminium foil cannot come into contact with the cavity walls since this may cause electrical arcing.

Lids

We recommend you use glass or plastic lids or cling film since:

1. This will stop excessive evaporation (mainly during very long cooking times);
2. The cooking times are shorter;
3. The food does not become dry;
4. The aroma is preserved.

The lid should have holes or openings so that no pressure develops. Plastic bags must also be opened. Baby feeding bottles or jars with baby food and similar containers can only be heated without their tops / lids otherwise they can burst.

Oven utensils and accessories guide

The list below is a general guide.

- : Utensils and accessories to use
- : Utensils and accessories to avoid

Type of ovenware	Operating mode			
	Microwave		Grill	Grill + Microwave
	Defrosting	Cooking		
Glass and china ¹⁾ Home use, not flame resistant, can be used in dish washer	✓	✓	✗	✗
Glazed china Flame resistant glass and china	✓	✓	✓	✓
China, stone ware ²⁾ Unglazed or glazed without metallic decorations	✓	✓	✗	✗
Clay dishes Keep the manufacturer's instructions in mind!) glazed	✓	✓	✗	✗
Clay dishes Keep the manufacturer's instructions in mind!) unglazed	✗	✗	✗	✗
Plastic dishes Keep the manufacturer's instructions in mind!) Heat resistant to 100°C	✓	✗	✗	✗
Plastic dishes Keep the manufacturer's instructions in mind!) Heat resistant to 250°C	✓	✓	✗	✗
Plastic films ³⁾ Plastic film for food	✗	✗	✗	✗
Plastic films ³⁾ Cellophane	✓	✓	✗	✗
Paper, cardboard, parchment ⁴⁾	✓	✗	✗	✗
Aluminium foil	✓	✗	✓	✗
Aluminium wrappings ⁵⁾	✗	✓	✓	✓

Type of ovenware	Operating mode			
	Microwave		Grill	Grill + Microwave
	Defrosting	Cooking		
Accessories (rectangular rack)	✗	✗	✓	✓

- 1) Without any gold or silver leaf edging; no lead crystal.
- 2) Keep the manufacturer's instructions in mind!
- 3) Do not use metal clips for closing bags. Make holes in the bags. Use the films only to cover the food.
- 4) Do not use paper plates.
- 5) Only shallow aluminium containers without lids/tops. The aluminium cannot come into contact with the cavity walls.

Food safety

- Do not heat food in a can in the microwave oven. Always remove the food to a suitable container.
- Deep fat frying should not be done in the microwave oven, because the fat temperature cannot be controlled, hazardous situations can result.
- Popcorn may be prepared in the microwave oven, but only in special packages or utensils designed specifically for this purpose. This cooking operation should never be unattended.
- Pierce foods with nonporous skins or membranes to prevent steam buildup and bursting. Apples, potatoes, chicken livers, and egg yolks are examples of items that should be pierced.
- The contents of feeding bottles and baby food jars are to be stirred or shaken and the temperature is to be checked before consumption, in order to avoid burns.



WARNING!

Liquids or other foods must not be heated in sealed containers since they are liable to explode.



WARNING!

Microwave heating of beverages can result in delayed eruptive boiling, therefore care must be taken when handling the container.



WARNING!

When heating liquids, e.g. soups, sauces and beverages in your microwave oven, overheating the liquid beyond boiling point can occur without evidence of bubbling. This could result in a sudden boil over of the hot liquid. To prevent this possibility the following steps should be taken:

1. Avoid using straight-sided containers with narrow necks.
2. Do not overheat.
3. Stir the liquid before placing the container in the oven and again halfway through the heating time.
4. After heating, allow to stand in the oven for a short time, stirring again before carefully removing the container.

**WARNING!**

Some products such as whole eggs and sealed containers - for example, closed glass jars - may explode and should not be heated in this oven. Occasionally, poached eggs may explode during cooking. Always pierce the yolk, then cover and allow the standing time of one minute before removing cover.



It is quite normal for steam to be emitted around the door, or for misting to occur on the door, or even for water droplets to appear below the door during the cooking cycle. This is merely condensation from the heat of the food and does not affect the safety of your oven. The door is not intended to seal the oven cavity completely.

Safety instructions when cooking with grill and combination modes

- The glass viewing window may break if water is spilled on it during grill cooking.
- Be sure to use an oven glove when loading and unloading the oven. Containers get very hot in the oven, so be careful not to burn yourself. The turntable and metal rack also get very hot so be sure to use an oven glove when handling them.
- Do not touch the inner or outer viewing window with metal components when loading or unloading the oven. The inside of the door and oven get very hot so take care when attending food in the oven.
- Do not put the turntable or containers in cold water or try to cool them quickly after use.
- Do not place items on top of the cabinet. The top of the cabinet gets very hot, so anything placed on it may be damaged by the heat.
- Preheat your oven only when using the Grill, never when using microwave or combination modes (Microwave and Grill)

**WARNING!**

When the appliance is used in combination mode, Children should only use the oven under adult supervision due to the temperature generated.

**WARNING!**

The temperature of accessible surface may be high when the appliance is operating.

Before first use

In conventional ovens, heat radiated by electrical elements or gas burners slowly penetrates the food from outside to inside. On account of this there is a major amount of energy is wasted heating the air, the oven components and the food containers.

In a microwave oven, heat is generated by the food itself and the heat travels from inside to outside. No heat is lost to the air, the walls of the oven cavity or the dishes and containers (if these are suitable for use in microwave oven), in other words, only the food is heated.

Microwave ovens have the following advantages:

1. Shorter cooking times; in general these are up to 3/4 less than the time required for conventional cooking.
2. Ultra-fast food defrosting, thus reducing the danger of bacterial development.
3. Energy savings.
4. Conservation of the nutritional value of foods due to the shorter cooking times.

5. Easy to clean.

How a microwave oven works

In a microwave oven there is a high tension valve called a magnetron which converts electrical energy into microwave energy. These electromagnetic waves are channelled to the interior of the oven through a wave guide and distributed by a metallic spreader or through a turntable.

Inside the oven the microwaves propagate in all directions and are reflected by the metal walls, uniformly penetrating the food.

Why food heats up

Most foods contain water and water molecules vibrate when subjected to microwaves. The friction between molecules produces heat which raises the temperature of the food, defrosting it, cooking it or keeping it hot.

Since the heat arises inside the food:

- This can be cooked with little or no liquid or fats/oils;
- Defrosting, heating or cooking in a microwave oven is quicker than in a conventional oven;
- The vitamins, minerals and nutritional substances in the food are conserved;
- The natural colour and aroma of the food are unchanged.

Microwaves pass through china, glass, cardboard or plastic but do not go through metal. For this reason, metal containers or ones with metal parts must not be used in a microwave oven.

Microwaves are reflected by metal ...

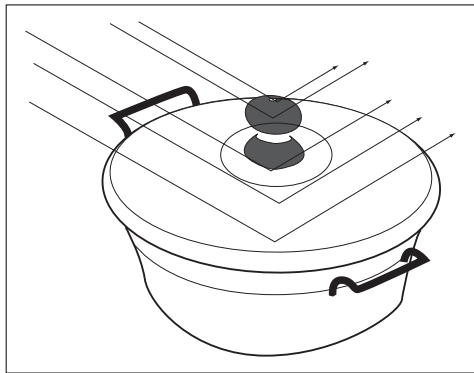



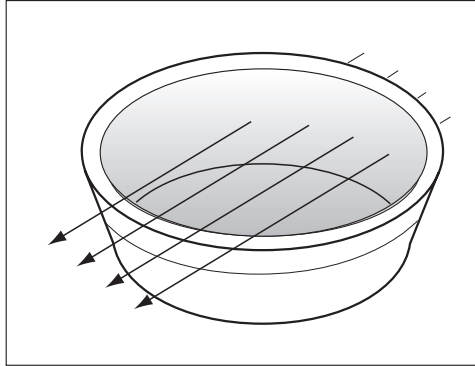

... but go through glass and china ...

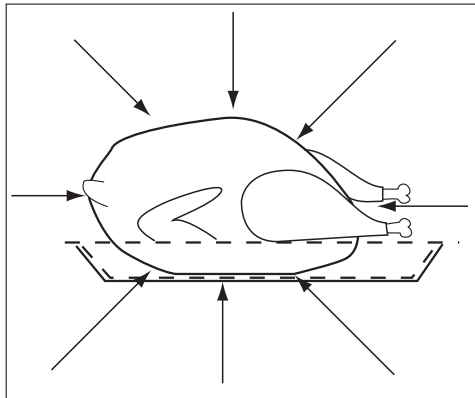





... and are absorbed by foods.



Description of functions

Symbol	Function	Microwave power	Foods
	Microwave	200W	Slow defrosting for delicate foods; keeping food warm
		400W	Cooking with little heat; boiling rice. Rapid defrosting, heating baby food
		600W	Heating and cooking food
		800W	Cooking vegetables and food. Cooking and heating carefully. Heating and cooking small portions of food
		1000W	Rapidly heating liquids

Symbol	Function	Microwave power	Foods
	Grill	---	Grilling food
	Microwave + grill	200W	Toasting food
		400W	Grilling poultry and meat
		600W	Cooking pies and cheese-topped dishes

Altering parameters

The operating parameters (time, power, temperature) can be altered when the oven is operating or when the cooking process has been interrupted by proceeding as follows:

1. Select the parameter to be change with the Parameter selection keys. The respective symbol and the display start blinking.
2. Set the desired value with the '+' and '-' keys.
3. Press the Confirmation key or wait 3 seconds to validate the new parameter value. The display and symbols stop blinking.

End of a cooking cycle

At the end of the process you will hear three beeps and the display will show the word "End".

The beeps are repeated every 30 seconds until the door is opened or the Cancel key is pressed.

Cancelling a cooking cycle

If you wish to cancel the cooking process, press the Cancel key twice.

You will then hear a beep and the time will appear on the display.

Interrupting a cooking cycle

You can stop the cooking process at any time by pressing the Cancel key once or by opening the oven door.

In both cases:

- Microwave emission is stopped immediately.
- The grill is de-activated but is still very hot. **Danger of burning!**
- The timer stops and the display shows the remaining amount of operating time.

If you wish, at this time you can:

1. Turn or stir the food to ensure it will be evenly cooked.
 2. Change the process parameters.
 3. Cancel the process by pressing the Cancel key.
- To restart the process, close the door and press the Start key

Product description

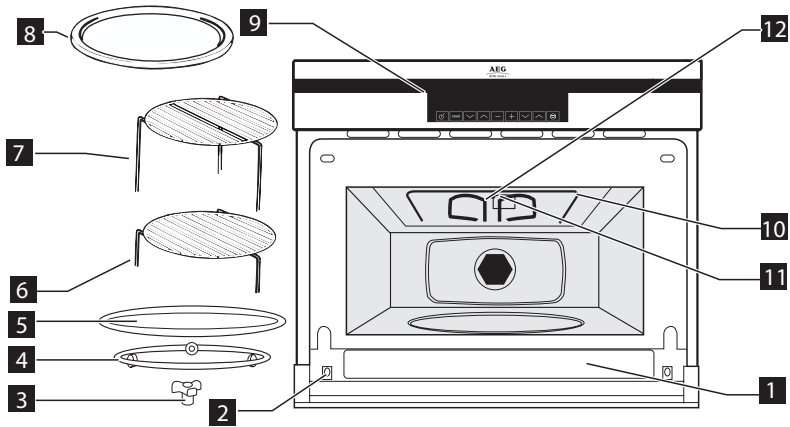

1. Door window glass
2. Interlock switch latches
3. Turntable drive shaft
4. Turntable support ring
5. Glass Turntable
6. Low grill rack
7. High grill rack
8. Crisping dish
9. Control Panel
10. Grill element
11. Oven Light
12. Grill fixing lug

The control panel

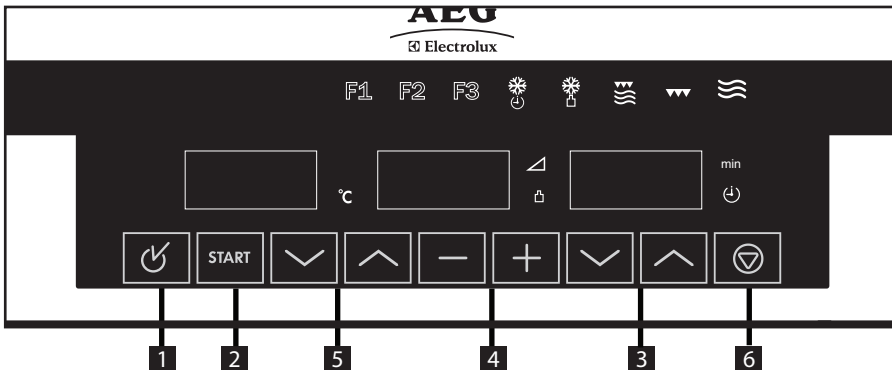

1. Confirmation key
2. Start / Quick Start key
3. Parameter selection keys

4. Plus and Minus keys
5. Function selection keys
6. Cancel

The display

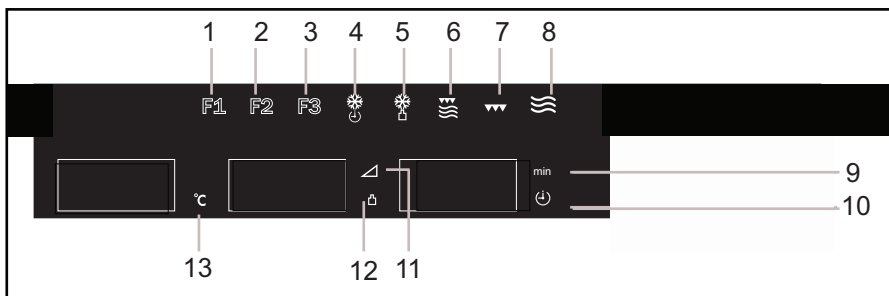

Symbol descriptions

1. F1 - Automatic function
2. F2 - Automatic function
3. F3 - Automatic function
4. Defrost by time
5. Defrost by weight
6. Grill + microwave
7. Grill
8. Microwave
9. Time
10. Clock
11. Power
12. Weight
13. Temperature

Operation

Setting the clock

The clock display will flash to indicate that the time shown is not correct.

To set the clock:

1. Select the Clock Symbol with the Parameter selection keys (Hours will flash) (this is not necessary if your microwave oven is first plugged in or after a power failure).
2. Set hours with the Plus and Minus keys.
3. Confirm the selection with the Confirmation key. (Min will flash)
4. Set inutes with the Plus and Minus keys.
5. Confirm the selection with the Confirmation key.

Hiding/Displaying the clock

If the clock display disturbs you, you can hide it.

To hide the clock:

1. Select the Clock Symbol with the Parameter selection keys.
2. Press and hold the Confirmation key for 3 seconds. The clock will be hidden but the dots between the hours and the minutes will flash once per second.

To show the clock again, repeat the above procedure.

Child lock

This oven has a feature which locks it to prevent it being used by children. After the lock has been set, no part of the microwave oven will operate until the child lock feature has been cancelled.

To set the child lock

1. To lock the oven, press the Cancel key for 3 seconds. You will hear a sound signal and the clock display will show the word "SAFE". The oven is locked in this state and cannot be used.
2. To unlock the oven, press the Cancel key again for 3 seconds. You will hear a sound signal and the clock display will show the time again.

Time of day can be viewed by pressing the cancel button momentarily.

Stopping the turntable

1. To stop the turntable, press Confirmation and Cancel keys for 3 seconds to get the word 'PLAT OFF' in the display
2. To start turntable rotation again, repeat the above procedure.

Cooking with microwave

Use this function to cook and heat vegetables, potatoes, rice, fish and meat.

1. Select the Microwave function with the Function selection keys.
2. Select the Power Level with Parameter selection keys. The Power Level symbol and display start blinking. If you do not change the power level the microwave operates with the default power 800 W.
3. Set the power level with the '+' and '-' keys.
4. Press the Confirmation key to validate the power level. The display and symbol stop blinking.
5. Select the Duration with Parameter selection keys. The Duration symbol and display start blinking.
6. Set the duration with the '+' and '-' keys.
7. Press the Confirmation key to validate the duration. The display and symbol stop blinking.
8. Start the cooking process by pressing the Start key.

When 1000 W power is selected, the duration is limited to a maximum of 15 minutes.

Quick start

Use this function to rapidly heat foods with high water content, such as water, coffee, tea or thin soup.

1. Press the Start key. The microwave oven operates for 30 seconds at maximum power.
2. If you want to increase the operating time press the Start key again. Each time you press this key the operating time will be increased by 30 seconds.

When 1000 W power is selected, the operating time is limited to a maximum of 15 minutes.

Cooking with grill

Use this function to brown the top of food quickly.

1. Select the Grill function with the Function selection keys.
2. Select the Duration with Parameter selection keys. The Duration symbol and display start blinking.
3. Set the duration with the '+' and '-' keys.
4. Press the Confirmation key to validate the duration. The display and symbol stop blinking.
5. Start the cooking process by pressing the Start key.

Cooking with microwave + grill

Use this function to cook lasagne, poultry, roast potatoes and toasted foods.

1. Select the Microwave + Grill function with the Function selection keys.
2. Select the Power Level with Parameter selection keys. The Power Level symbol and display start blinking. If you do not change the power level the microwave operates with the default power 600 W.
3. Set the power level with the '+' and '-' keys.
4. Press the Confirmation key to validate the power level. The display and symbol stop blinking.
5. Select the Duration with Parameter selection keys. The Duration symbol and display start blinking.
6. Set the duration with the '+' and '-' keys.
7. Press the Confirmation key to validate the duration. The display and symbol stop blinking.
8. Start the cooking process by pressing the Start key.

Automatic defrost

Use this function to defrost meat, poultry, fish, fruit and bread quickly by weight.

1. Select the Defrost by Weight function with the Function selection keys.
2. Select the Program with Parameter selection keys. The Duration and Clock symbols and the display start blinking.
3. Set the program with the '+' and '-' keys (refer to the table below).
4. Press the Confirmation key to validate the program. The display and symbols stop blinking.
5. Select the Weight with Parameter selection keys. The Weight symbol and display start blinking.
6. Set the weight with the '+' and '-' keys.
7. Press the Confirmation key to validate the weight. The display and symbol stop blinking.
8. Start the cooking process by pressing the Start key.

The following table shows the defrosting by weight function programmes, indicating weight intervals, and defrosting and standing times (in order to ensure the food is of a uniform temperature).

Programme	Food	Weight (g)	Time (min)	Standing time (min)
Pr01	meat	100 - 2000	2 - 43	20 - 30
Pr02	Poultry	100 - 2500	2 - 58	20 - 30

Programme	Food	Weight (g)	Time (min)	Standing time (min)
Pr03	Fish	100 - 2000	2 - 40	20 - 30
Pr04	Fruit	100 - 500	2 - 13	10 - 20
Pr05	Bread	100 - 800	2 - 19	10 - 20

Manual defrost

Use this function to defrost any type of food quickly by setting the defrost time.

1. Select the Defrost by Time function with the Function selection keys.
2. Select the Duration with Parameter selection keys. The Duration symbol and display start blinking.
3. Set the duration with the '+' and '-' keys.
4. Press the Confirmation key to validate the duration. The display and symbol stop blinking.
5. Start the cooking process by pressing the Start key.

To speed up the defrosting of dense foods over 450g (1lb), the oven may be started on full power for 1 - 3 minutes, and then reduced to defrost until defrosting is complete. At the end of this function a bell will be heard to signal the end of the program.

Automatic function F1 (heating food)

Use this function to heat various types of food.

1. Select the Automatic function F1 with the Function selection keys.
2. Select the Program with Parameter selection keys. The Duration and Clock symbols and the display start blinking.
3. Set the program with the '+' and '-' keys (refer to the table below).
4. Press the Confirmation key to validate the program. The display and symbols stop blinking.
5. Select the Weight with Parameter selection keys. The Weight symbol and display start blinking.
6. Set the weight with the '+' and '-' keys.
7. Press the Confirmation key to validate the weight. The display and symbol stop blinking.
8. Start the cooking process by pressing the Start key.

The following table shows the Automatic Function F1 programmes, indicating weight intervals, and defrosting and standing times (in order to ensure the food is of a uniform temperature).

Programme	Food	Weight (Kg)	Time (min)	Standing time (min)
A 01	Soup	200 - 1500	3 - 5	Turn 1-2 x, keep covered, 1-2 min.
A 02	Pre-prepared dishes dense food	200 - 1500	3 - 20	Turn 1-2 x, keep covered, 1-2 min.
A 03	Pre-prepared dishes e.g. goulash	200 - 1500	3 - 18	Turn 1-2 x, keep covered, 1-2 min.

Programme	Food	Weight (Kg)	Time (min)	Standing time (min)
A 04	Vegetables	200 - 1500	2,6 - 14	Turn 1-2 x, keep covered, 1-2 min.

Important Notes:

- Always use dishes for use in the microwave oven and a lid or cover to avoid loss of liquids.
- Stir or mix the foods several times during heating, especially when the oven emits a beep and the display is flashing as follows: .
- The time required to heat the food will depend on its initial temperature. Food taken straight from the fridge will take longer to heat up than food that is at room temperature. If the food temperature is not suitable, select a greater or lesser weight next time you heat up the food.
- After heating, stir the food or shake the container and then leave the food to stand for some time to allow the temperature to become uniform throughout the food.

**WARNING!**

After heating the container may be very hot. Although microwaves do not heat up most containers, these may heat up through heat transmission from food.

Automatic function F2 (cooking)

Use this function to cook fresh food

1. Select the Automatic function F2 with the Function selection keys.
2. Select the Program with Parameter selection keys. The Duration and Clock symbols and the display start blinking.
3. Set the program with the '+' and '-' keys (refer to the table below).
4. Press the Confirmation key to validate the program. The display and symbols stop blinking.
5. Select the Weight with Parameter selection keys. The Weight symbol and display start blinking.
6. Set the weight with the '+' and '-' keys.
7. Press the Confirmation key to validate the weight. The display and symbol stop blinking.
8. Start the cooking process by pressing the Start key.

The following table shows the Automatic Function F2 programmes, indicating weight intervals, and defrosting and standing times (in order to ensure the food is of a uniform temperature).

Programme	Food	Weight (Kg)	Time (min)	Standing time (min)
B 01	Potatoes	200 - 1000	4 - 17	Turn 1-2 x, keep covered, 1-2 min.
B 02	Vegetables	200 - 1000	4 - 15	Turn 1-2 x, keep covered, 1-2 min.
B 03	Rice	200 - 500	13 - 20	One part rice, two parts water, keep covered
B 04	Fish	200 - 1000	4 - 1000	Keep covered

Important Notes:

- Always use dishes for use in the microwave oven and a lid or cover to avoid loss of liquids.
- Stir or mix the foods several times during heating, especially when the oven emits a beep and the display is flashing as follows .

**WARNING!**

After heating the container may be very hot. Although microwaves do not heat up most containers, these may heat up through heat transmission from food.

Preparation instructions:

- Fish pieces – Add 1 to 3 soup spoons of water or lemon juice.
- Rice – Add water equivalent to twice or three times the quantity of rice.
- Unpeeled potatoes – Use potatoes of the same size. Wash them and prick the skin several times. Do not add water.
- Peeled potatoes and Fresh vegetables – Cut into pieces of the same size. Add a soup spoon of water for every 100 g of vegetables, and salt to taste.

Automatic function F3 (defrosting and toasting)

Use this function to cook and toast various types of food.

1. Select the Automatic function F3 with the Function selection keys.
2. Select the Program with Parameter selection keys. The Duration and Clock symbols and the display start blinking.
3. Set the program with the '+' and '-' keys (refer to the table below).
4. Press the Confirmation key to validate the program. The display and symbols stop blinking.
5. Select the Weight with Parameter selection keys. The Weight symbol and display start blinking.
6. Set the weight with the '+' and '-' keys.
7. Press the Confirmation key to validate the weight. The display and symbol stop blinking.
8. Start the cooking process by pressing the Start key.

The following table shows the Automatic Function F3 programmes, indicating weight intervals, and defrosting and standing times (in order to ensure the food is of a uniform temperature).

Programme	Food	Weight (Kg)	Time (min)	Standing time (min)
C 01	Pizza	300 - 550	3 - 9	Preheat the baking pan
C 02	Deep frozen food	400 - 1000	8 - 14	Turn 1-2 x, keep covered, 1-2 min.
C 03	Frozen potato dishes	200 - 450	10 - 12	Turn 1x

Important Notes:

- Always use dishes for use in the microwave oven and a lid or cover to avoid loss of liquids.
- Stir or mix the foods several times during heating, especially when the oven emits a beep and the display is flashing as follows .

**WARNING!**

After heating the container may be very hot. Although microwaves do not heat up most containers, these may heat up through heat transmission from food.

Preparation instructions:

- Frozen pizza – Use pre-cooked frozen pizzas and pizzas-rolls.
- Deep-frozen food – Use lasagne, cannelloni, prawn soufflé, all frozen. Keep covered.
- Frozen potato dishes, frozen – Chips, potato croquettes and fried potatoes must be suitable for preparation in the oven.

Hints and tips

Microwave

**WARNING!**

Read the section 'Important safety information' before cooking with your microwave.

Follow these recommendations when cooking with your microwave:

- Before heating or cooking foods with peel or skin (e.g. apples, tomatoes, potatoes, sausages) prick them so that they do not burst. Cut the food up before starting to prepare it.
- Before using a container or dish make sure that it is suitable for microwave use (see the section on types of ovenware).
- When cooking food with very little moisture (e.g. defrosting bread, making popcorn, etc.) evaporation is very quick. The oven then works as if it was empty and the food may burn. The oven and the container may be damaged in such a situation. You should therefore set just the cooking time necessary and you must keep a close eye on the cooking process.
- It is not possible to heat large quantities of oil (frying) in the microwave.
- Remove pre-cooked food from the containers they come in since these are not always heat resistant. Follow the food manufacturer's instructions.
- If you have several containers, such as cups, for example, set them out uniformly on the turntable plate.
- Do not close plastic bags with metal clips. Use plastic clips instead. Prick the bags several times so that the steam can escape easily.
- When heating or cooking foods, check that they reach at least a temperature of 70°C.
- During cooking, steam may form on the oven door window and may start to drip. This situation is normal and may be more noticeable if the room temperature is low. The oven's safe working is not affected by this. After you have finished cooking, clean up the water coming from the condensation.
- When heating liquids, use containers with a wide opening, so that the steam can evaporate easily.

Prepare the foods as per the instructions and keep in mind the cooking times and power levels indicated in the tables.

Keep in mind that the figures given are only indicative and can vary depending on the initial state, temperature, moisture and type of food. It is advisable to adjust the times and power levels to each situation. Depending on the exact characteristics of the food you may need to increase or shorten the cooking times or increase or decrease the power levels.

Cooling with microwaves...

1. The greater the amount of food, the longer the cooking time. Keep in mind that:
 - Double the quantity » double the time
 - Half the quantity » half the time
2. The lower the temperature, the longer the cooking time.
3. Foods containing a lot of liquid heat up more quickly.
4. Cooking will be more uniform if the food is evenly distributed on the turntable. If you put dense foods on the outside part of the plate and less dense ones on the centre of the plate, you can heat up different types of food simultaneously.
5. You can open the oven door at any time. When you do this the oven switches off automatically. The microwave will only start working again when you close the door and press the start key.
6. Foods that are covered require less cooking time and retain their characteristics better. The lids used must let microwaves pass through and have small holes that allow steam to escape.

Defrosting

1. When defrosting, use only dishes that are appropriate for microwaves (china, glass, suitable plastic).
2. The defrost function by weight and the tables refer to the defrosting of raw food.
3. The defrosting time depends on the quantity and thickness of the food. When freezing food keep the defrosting process in mind. Distribute the food evenly in the container.
4. Distribute the food as best as possible inside the oven. The thickest parts of fish or chicken drumsticks should be turned towards the outside. You can protect the most delicate parts of food with pieces of aluminium foil. Important: The aluminium foil must not come into contact with the oven cavity interior as this can cause electrical arcing.
5. Thick portions of food should be turned several times.
6. Distribute the frozen food as evenly as possible since narrow and thin portions defrost more quickly than the thicker and broader parts.
7. Fat-rich foods such as butter, cream cheese and cream should not be completely defrosted. If they are kept at room temperature they will be ready to be served in a few minutes. With ultra-frozen cream, if you find small pieces of ice in it, you should mix these in before serving.
8. Place poultry on an upturned plate so that the meat juices can run off more easily.
9. Bread should be wrapped in a napkin so that it does not become too dry.
10. Turn the food whenever the oven lets out a beep and the display flashes the word:
11. Remove frozen food from its wrapping and do not forget to take off any metal twist-tags. For containers that are used to keep frozen food in the freezer and which can also be used for heating and cooking, all you need to do is take off the lid. For all other cases you should put the food into containers that are suitable for microwave use.
12. The liquid resulting from defrosting, principally that from poultry, should be discarded. In no event should such liquids be allowed to come into contact with other foods.
13. Do not forget that by using the defrosting function you need to allow for standing time until the food is completely defrosted.

Grill

For good results with the grill, use the rectangular rack supplied with the oven.

Important points

1. When the microwave grill is used for the first time there will be some smoke and a smell coming from the oils used during oven manufacture.
2. The oven door window becomes very hot when the grill is working. Keep children away.
3. When the grill is operating, the cavity walls and the rectangular rack become very hot. You should use oven gloves.
4. If the grill is used for extended period of time it is normal to find that the elements will switch themselves off temporarily due to the safety thermostat.
5. **Important!** When food is to be grilled or cooked in containers you must check that the container in question is suitable for microwave use. See the section on types of ovenware!
6. When the grill is used it is possible that some splashes of fat may go onto the elements and be burnt. This is a normal situation and does not mean there is any kind of operating fault.
7. After you have finished cooking, clean the interior and the accessories so that cooking remains do not become encrusted.

Heat up the grill beforehand for 2 minutes. Unless indicated otherwise, use the rectangular rack.

Place the grid on a bowl so that the water and the fat can drop. The times shown are merely indicative and can vary as a function of the composition and quantity of the food, as well as the final condition wished for. Fish and meat taste great if, before grilling, you brush them with vegetable oil, spices and herbs and leave to marinate for a few hours. Only add salt after grilling.

Sausages will not burst if you prick them with a fork before grilling.

After half the grilling time has passed, check on how the cooking is going and, if necessary, turn the food over or brush it with some oil.

The grill is especially suitable for cooking thin portions of meat and fish. Thin portions of meat only need to be turned once, but thicker portions should be turned several times. In the case of fish, you should join the two ends, putting the tail in its mouth, and then put the fish on the rectangular rack.

Microwave + grill



WARNING!

To avoid arcing do not use the rectangular rack when cooking with microwave and grill.

The microwave + grill function is ideal for cooking quickly and, at the same time, browning foods.

Furthermore, you can also grill and cook cheese covered food.

The microwave and the grill work simultaneously. The microwave cooks and the grill toasts. Before using a dish in the microwave oven make sure that it is suitable for microwave use. Only use dishes or containers that are suitable for microwave use.

The dish to be used in the combined function must be suitable for microwave and grill use. See the section on types of ovenware!

Keep in mind that the figures given are merely indicative and can vary as a function of the initial state, temperature, moisture and type of food.

If the time is not enough to brown the food well, put it under the grill for another 5 or 10 minutes.

Please follow the standing times and don't forget to turn the meat pieces.

Unless indicated to the contrary, use the turntable plate for cooking.

The values given in the tables are valid when the oven cavity is cold (it is not necessary to pre-heat the oven).

Something not working



WARNING!

Any type of repair must only be done by a specialised technician. Any repair done by a person not authorised by the manufacturer is dangerous.

You do not need to contact Technical Assistance to resolve the following questions:

Problem	Possible solution (Check if.....)
The display is not showing!	The time indication has been switched off
Nothing happens when I press the keys!	The Child lock is active (cancel the child lock).
The oven does not work!	The plug is correctly fitted in the socket.
	The oven's power is switched on.
	The door is completely closed. The door should close with an audible click.
	There are any foreign bodies between the door and the cavity front.
When the oven is operating I can hear some strange noises!	There is any electrical arcing inside the oven caused by foreign metallic objects.
	The ovenware is touching the oven walls.
	There are any loose items of cutlery or cooking tools inside the oven.
The food doesn't heat up or heats very slowly!	You have inadvertently used metal ovenware.
	You have selected the correct operating times and power level.
	The food you have put inside the oven is a larger amount or colder than you usually put in.
The food is too hot, dried out or burnt!	Have you selected the correct operating time and power level.
I hear some noises after the cooking process is finished!	This is not a problem. The cooling fan keeps on working for some time. When the temperature has dropped sufficiently, the fan will switch itself off.
The oven switches on but the interior light does not go on!	If all the functions work properly it is probable that the lamp has blown. You can keep on using the oven.

Replace the light bulb

To replace the light bulb,

1. Disconnect the oven from the power supply. Take the plug out of the socket or switch off the oven's power circuit.
2. Unscrew and remove the glass light cover (1).
3. Remove the halogen light bulb (2).



WARNING!

The bulb may be very hot.

4. Fit a new 12V / 10W halogen bulb.



WARNING!

Do not touch the light bulb surface directly with your fingers because you may damage the bulb. Follow the lamp manufacturer's instructions.

5. Screw the glass light cover into place (1).
6. Connect the oven again to the power supply.

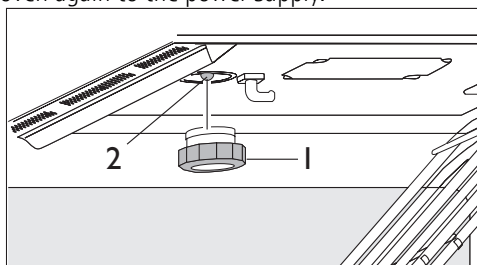

Maintenance and cleaning

Cleaning is the only maintenance normally required.



WARNING!

Your microwave oven should be cleaned regularly, removing all food remains. If the microwave is not kept clean its surfaces may deteriorate, reducing the oven's working life and possibly resulting in a dangerous situation.



WARNING!

Cleaning should be done with the oven power switched off. Take the plug out of the socket or switch off the oven's power circuit.

Do not use aggressive or abrasive cleaning products, scourers that scratch surfaces or sharp objects, since stains may appear.

Do not use high pressure or stream jet cleaning appliances.

Front surface

Normally you just need to clean the oven with a damp cloth. If it is very dirty, add a few drops of dish washing liquid to the cleaning water. Afterwards, wipe the oven with a dry cloth.

Use a glass cleaning product and a soft cloth that does not release any fibres or threads. Wipe from side to side without exerting any pressure on the surface. Immediately remove lime, fat, starch or egg white stains. Corrosion can occur under these stains.

Do not let any water get inside the oven.

Oven interior

After each time the oven is used, clean the inside walls with a damp cloth since this is the easiest way to remove splashes or spots of food that may have stuck to the inside.

To remove dirt that is harder to shift, use a non-aggressive cleaning product. Do not use oven sprays or other aggressive or abrasive cleaning products.

Always keep the door and the oven front very clean to ensure that the door opens and closes properly.

Make sure water does not enter the microwave ventilation holes.

Regularly take out the turntable plate and the respective support and clean the cavity base, especially after any liquid spillage.

Do not switch on the oven without the turntable and the respective support being in place. If the oven cavity is very dirty, put a glass of water on the turntable and switch on the microwave oven for 2 or 3 minutes at maximum power. The steam released will soften the dirt which can then be cleaned easily using a soft cloth.

Unpleasant odours (e.g. after cooking fish) can be eliminated easily. Put a few drops of lemon juice in a cup with water. Put a spoonful of coffee in the cup to avoid the water boiling over. Heat the water for 2 to 3 minutes at maximum microwave power.

Oven ceiling

If the oven ceiling is dirty, the grill can be lowered to make cleaning easier.



WARNING!

To avoid the danger of burning, wait until the grill is cold before lowering it.

Proceed as follows:

1. Turn the grill support by 90° (1).
2. Lower the grill gently (2). Do not use excessive force as this may cause damage.
3. After cleaning the ceiling, put the grill (2) back in its place, carrying out the previous operation.

The mica cover (3) located in the ceiling must always be kept clean. Any food remains that collect on the mica cover can cause damage or provoke sparks.

Do not use abrasive cleaning products or sharp objects.



WARNING!

To avoid any risk, do not remove the mica cover.

The glass lamp cover (4) is located on the oven ceiling and can be removed easily for cleaning. For this you just need to unscrew it and clean it with water and dish washing liquid.

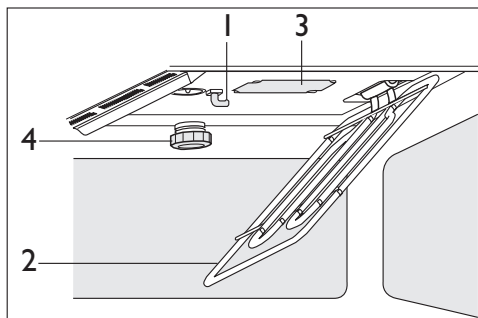

Accessories

Clean the accessories after each use. If they are very dirty, soak them first of all and then use a brush and sponge. The accessories can be washed in a dish washing machine.

Make sure that the turntable plate and the respective support are always clean. Do not switch on the oven unless the turntable and the respective support are in place.

Environmental information

The symbol  on the product or on its packaging indicates that this product may not be treated as household waste. Instead it should be taken to the appropriate collection point for the recycling of electrical and electronic equipment. By ensuring this product is disposed of correctly, you will help prevent potential negative consequences for the environment and human health, which could otherwise be caused by inappropriate waste handling of this product. For more detailed information about recycling of this product, please contact your local council, your household waste disposal service or the shop where you purchased the product.

Installation

Before installation

- Check that the input voltage indicated on the rating plate is the same as the voltage of the power outlet you are going to use.
- Open the oven door and take out all the accessories and remove the packing material.
- Do not remove the mica cover on the ceiling of the interior! This cover stops fat and pieces of food damaging the microwave generator.



WARNING!

Warning! The front surface of the oven may be wrapped with a protective film. Before using the oven for the first time, carefully remove this film, starting on the inside.

- Make sure that the oven is not damaged in any way. Check that the oven door closes correctly and that the interior of the door and the front of the oven opening are not damaged. If you find any damage contact the Technical Assistance Service.

- DO NOT USE THE OVEN if the power cable or the plug are damaged, if the oven does not function correctly or if it has been damaged or dropped. Contact the Technical Assistance Service.
- Put the oven on a flat and stable surface. The oven must not be installed close to any sources of heat, radios or televisions.
- During installation, make sure that the power cable does not come into contact with any moisture or objects with sharp edges behind the oven. High temperatures can damage the cable.

**WARNING!**

after the oven is installed you must make sure you can access the plug.

After installation

- The oven is equipped with a power cable and a plug for single phase current.
- If the oven is to be installed on a permanent basis it should be installed by a qualified technician. In such a case, the oven should be connected to a circuit with an all-pole circuit breaker with a minimum separation of 3 mm between contacts.

**WARNING!**

THE OVEN MUST BE EARTHED.

- The manufacturer and retailers do not accept responsibility for any damage that may be caused to people, animals or property if these installation instructions are not observed.
- The oven only functions when the door is closed correctly.
- After the first use, clean the inside of the oven and the accessories, following the cleaning instructions given in the section 'Maintenance and cleaning'.

Fit the Turntable support (1) in the centre of the oven cavity and put the Turntable ring (2) and the Turntable plate (3) on top, making sure they slot in. Whenever you use the microwave, the turntable plate and the respective accessories must be inside and correctly fitted. The turntable plate can rotate in both directions.

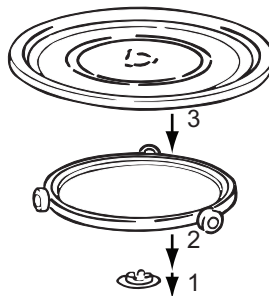

Installation diagrams

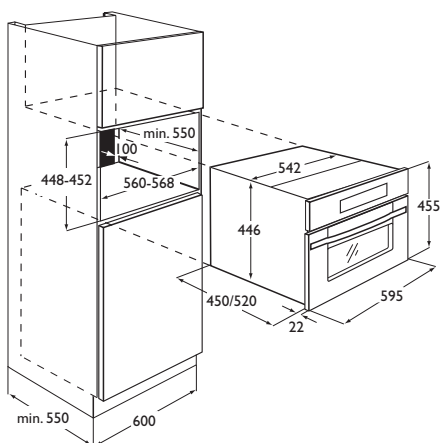
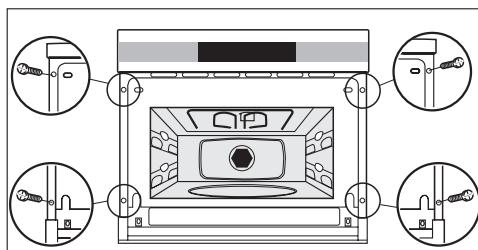
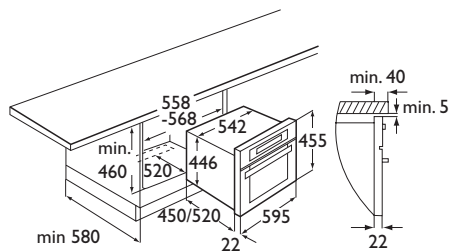

1. Push oven completely into the cabinet and centre it.
2. Open microwave door and fasten the appliance to the cabinet using the four screws provided. Insert the screws through the front holes.

Technical data

Technical data category	Value
AC Voltage	(see rating plate)
Power required	3300 W

Technical data category	Value
Grill power	1500 W
Microwave output power	1000 W
Microwave frequency	2450 MHz
Exterior dimensions (WxHxD)	595 x 455 x 542 mm
Interior dimensions (WxHxD)	420 x 210 x 390 mm
Oven capacity.	32 ltr
Weight	35 kg

GB **IE** Guarantee/Customer Service

GREAT BRITAIN & IRELAND

Standard guarantee conditions

We, Electrolux, undertake that if within 12 months of the date of the purchase this Electrolux appliance or any part thereof is proved to be defective by reason only of faulty workmanship or materials, we will, at our option repair or replace the same FREE OF CHARGE for labour, materials or carriage on condition that:

- Appliance has been correctly installed and used only on the electricity supply stated on the rating plate.
- Appliance has been used for normal domestic purposes only, in accordance with manufacturer's instructions.
- Appliance hasn't been serviced, maintained, repaired, taken apart or tampered with by person not authorised by us.
- Electrolux Service Force Centre must undertake all service work under this guarantee
- Any appliance or defective part replaced shall become the Company's property.
- This guarantee is in addition to your statutory and other legal rights.

Exclusions

- Damage, calls resulting from transport, improper use, neglect, light bulbs, removable parts of glass, plastic.
- Costs for calls to put right appliance which is improperly installed, calls to appliances outside United Kingdom.
- Appliances found to be in use within a commercial environment, plus those which are subject to rental agreements.
- Products of Electrolux manufacturer that are not marketed by Electrolux

Service and Spare Parts

If your appliance requires service or spare parts, contact your local Service Force Centre: **0870 5 929 929** (Call will be routed to Service Force Centre covering your postcode area). For address of local Service Force Centre and further information, please visit: **www.serviceforce.co.uk**

Before calling out an engineer, please ensure you have read the details under the heading "What to do if..."

When you contact the Service Force Centre you will need to give the following details:

Your name, address and postcode, your telephone number, clear concise details of the fault, model and serial number of the appliance (found on the rating plate), the purchase date. Please note a valid purchase receipt or guarantee documentation is required for in guarantee service calls.

Customer Care

For general enquiries concerning your Electrolux appliance, or for information on Electrolux products, contact our Customer Care Department by letter or telephone at the address below or visit our website at www.electrolux.co.uk

Customer Care Department, Electrolux Major Appliances, Addington Way, Luton, Bedfordshire, LU4 9QQ

	Tel: (Calls may be recorded for training purposes)
Electrolux	08705 950 950
AEG-Electrolux	08705 350 350
Zanussi-Electrolux	08705 727 727

For Customer Service in The Republic of Ireland please contact us at the address below:

Electrolux Group (Irl) Ltd, Long Mile Road, Dublin 12, Republic of Ireland

Tel: +353 (0)1 4090751, Email: service.eid@electrolux.ie

European Guarantee

This appliance is guaranteed by Electrolux in each of the countries listed at the back of this user manual, for the period specified in the appliance guarantee or otherwise by law. If you move from one of these countries to another of the countries listed, the appliance guarantee will move with you subject to the following qualifications:-

- The appliance guarantee starts from the date you first purchased the appliance which will be evidenced by production of a valid purchase document issued by the seller of the appliance.
- The appliance guarantee is for the same period and to the same extent for labour and parts as exists in your new country of residence for this particular model or range of appliances.
- The appliance guarantee is personal to the original purchaser of the appliance and cannot be transferred to another user.
- The appliance is installed and used in accordance with instructions issued by Electrolux and is only used within the home, i.e. is not used for commercial purposes.
- The appliance is installed in accordance with all relevant regulations in force within your new country of residence.

The provisions of this European Guarantee do not affect any of the rights granted to you by law.

www.electrolux.com

		
Albania	+35 5 4 261 450	Rr. Pjeter Bogdani Nr. 7 Tirane
Belgique/België/Belgien	+32 2 363 04 44	Bergensesteenweg 719, 1502 Lembeek
Česká republika	+420 2 61 12 61 12	Budějovická 3, Praha 4, 140 21
Danmark	+45 70 11 74 00	Sjællandsgade 2, 7000 Fredericia
Deutschland	+49 180 32 26 622	Muggenhofer Str. 135, 90429 Nürnberg
Eesti	+37 2 66 50 030	Pärnu mnt. 153, 11624 Tallinn
España	+34 902 11 63 88	Carretera M-300, Km. 29,900 Alcalá de Henares Madrid
France	08 44 62 26 53	www.electrolux.fr
Great Britain	+44 8705 929 929	Addington Way, Luton, Bedfordshire LU4 9QQ
Hellas	+30 23 10 56 19 70	4, Limnou Str., 54627 Thessaloniki
Hrvatska	+385 1 63 23 338	Slavonska avenija 3, 10000 Zagreb
Ireland	+353 1 40 90 753	Long Mile Road Dublin 12
Italia	+39 (0) 434 558500	C.so Lino Zanussi, 26 - 33080 Porcia (PN)
Latvija	+371 67313626	Kr. Barona iela 130/2, LV-1012, Riga
Lietuva	+370 5 278 06 03	Ozo 10a, LT-08200 Vilnius
Luxembourg	+352 42 431 301	Rue de Bitbourg, 7, L-1273 Hamm
Magyarország	+36 1 252 1773	H-1142 Budapest XIV, Erzsébet királyné útja 87
Nederland	+31 17 24 68 300	Vennootsweg 1, 2404 CG - Alphen aan den Rijn
Norge	+47 81 5 30 222	Risløkkvn. 2 , 0508 Oslo
Österreich	+43 18 66 400	Herziggasse 9, 1230 Wien
Polska	+48 22 43 47 300	ul. Kolejowa 5/7, Warszawa

		
Portugal	+35 12 14 40 39 39	Quinta da Fonte - Edificio Gonçalves Zarco - Q. 35 -2774-518 Paço de Arcos
Romania	+40 21 451 20 30	Str. Garii Progresului 2, S4, 040671 RO
Schweiz - Suisse - Svizzera	+41 62 88 99 111	Industriestrasse 10, CH-5506 Mägenwil
Slovenija	+38 61 24 25 731	Gerbičeva ulica 98, 1000 Ljubljana
Slovensko	+421 2 43 33 43 22	Electrolux Slovakia s.r.o., Electrolux Domáce spotrebiče SK, Seberíniho 1, 821 03 Bratislava
Suomi	www.electrolux.fi	
Sverige	+46 (0)771 76 76 76	Electrolux Service, S:t Göransgatan 143, S-105 45 Stockholm
Türkiye	+90 21 22 93 10 25	Tarlabası caddesi no : 35 Taksim İstanbul
Россия	+7 495 937 7837	129090 Москва, Олимпийский проспект, 16, БЦ "Олимпик"
Україна	+380 44 586 20 60	04074 Київ, вул.Автозаводська, 2а, БЦ "Алкон"

