

Operating and Installation Instructions

SU 96000-6I

Built-In Refrigerator

Dear customer,

Before switching on your new appliance please read these operating instructions carefully. They contain important information for safe use, for installation and for care of the appliance.

Please keep these operating instructions for future reference. Pass them on to possible new owners of the appliance.

These operating instructions are for use with several technically comparable models with varying accessories. Please observe the notes which apply to your model.



Notes which are important for your safety or for the proper functioning of the appliance are stressed with a warning triangle and/or with signal words (**Warning!**, **Caution!**, **Important!**). Please observe the following carefully.



1. This symbol guides you step by step in the operation of the appliance.
2.



Supplementary information regarding operation and practical applications of the appliance appear after this symbol.



Tips and notes concerning economical and environmentally sound use of the appliance are marked with the cloverleaf.

Explanations of the technical terminology used in the operating instructions can be found at the end in the section "Technical Terminology".

The operating instructions contain instructions for the correction of possible malfunctions by the user in the section "What to do if ...". If these instructions should not be sufficient, contact your local Service Force Centre.

Printed on paper manufactured with environmentally sound processes
he who thinks ecologically acts accordingly...

Contents

Important Safety Instructions	4
Disposal	6
Appliance Packaging Information.....	6
Disposal of old Appliances	6
Remove transport packaging	7
Installation	7
Installation Location.....	7
Grid preparation.....	8
Reversing the door.....	9
Building the appliance in under a worktop.....	10
Fitting the plinth.....	15
Power supply.....	15
Electrical Connection	16
Description of the appliance	17
View of the appliance.....	17
Prior to Initial Start-Up	17
Starting up and temperature regulation	18
Switching off the appliance	19
Interior Accessories	19
Storage shelves.....	19
Variable storage box	20
Bottle Holder	20
Correct storage	21
Defrosting	21
The fridge defrosts automatically.....	21
Cleaning and Care	22
Energy Saving Tips	23
What to do if....	23
Correcting Malfunctions	23
Changing the light bulb	25
Noises during Operation	25
Regulations, Standards, Guidelines	25
Technical terminology	26



Important Safety Instructions

These warnings are provided in the interests of your safety. Ensure you fully understand them before installing or using the appliance. Your safety is of paramount importance. If you are unsure about the meaning of these warnings contact the Customer Care Department for assistance.

Intended use

- The refrigerator is intended for use in the home. It is suitable for the storing of food at low temperature. If the appliance is used for purposes other than those intended or used incorrectly, no liability can be accepted by the manufacturer for any damage that may be caused.
- Alterations or changes to the refrigerator are not permitted for reasons of safety.
- If you use the refrigerator in a commercial application or for purposes other than the cooling of foods, the manufacturer accepts no liability for any damages which may occur.

Prior to initial start-up

- Ensure that the appliance does not stand on the electrical supply cable. **Important:** if the supply cable is damaged, it must be replaced by authorised service or qualified personnel using a special cable of the same type.
- Check the appliance for transport damage. Under no circumstance should a damaged appliance be plugged in. In the event of damage, please contact your supplier.

Refrigerant

The refrigerant isobutane (R600a) is contained within the refrigerant circuit of the appliance, a natural gas with a high level of environmental compatibility, which is nevertheless flammable.

- **Warning** - During transportation and installation of the appliance, be certain that none of the components of the refrigerant circuit become damaged.
- If the refrigerant circuit should become damaged:
 - avoid open flames and sources of ignition;
 - thoroughly ventilate the room in which the appliance is situated.

Safety of children

- Packaging (e.g. wraps, polystyrene) can be dangerous for children. There is a risk of suffocation! Keep packaging material away from children!
- Please make old appliances unusable prior to disposal. Pull out the mains plug, cut off the mains cable, break or remove spring or bolt catches, if fitted. By doing this you ensure that children cannot lock themselves in the appliance when playing (there is risk of suffocation!) or get themselves into other dangerous situations.
- Often children cannot recognise the hazards present in household appliances. It is therefore important that you ensure adequate supervision and never let children play with the appliance!

Daily Operation

- Containers with flammable gases or liquids can leak at low temperatures. There is a risk of an explosion! Do not store any containers with flammable materials such as spray cans, fire extinguisher refill cartridges etc in the refrigerator and/or freezer.
- **Warning** - Do not operate any electrical appliances in the refrigerator and/or freezer (e.g. electric ice cream makers, mixers etc.).
- **Warning** - In order not to impair the function of the appliance, never cover or obstruct the ventilation openings.
- **Warning** - Do not damage the cooling circuit.
- Before cleaning the appliance, always switch off the appliance and unplug it, or pull the house fuse or switch off the circuit breaker.
- When unplugging always pull the plug from the mains socket, do not pull on the cable.

In case of malfunction

- If a malfunction occurs on the appliance, please look first in the "What to do if ..." section of these instructions. If the information given there does not help, please do not perform any further repairs yourself.
- Under no circumstance should you attempt to repair the appliance yourself. Repairs carried out by inexperienced persons may cause injury or serious malfunctioning. Contact your local Service Force Centre.

Disposal

Appliance Packaging Information

All materials are environmentally sound! They can be disposed of or burned at an incinerating plant without danger.

About the materials: The plastics can be recycled and are identified as follows:

>PE< for polyethylene, e.g. the outer covering and the bags in the interior.

>PS< for polystyrene foam, e.g. the pads, which are all free of chlorofluorocarbon.

The carton parts are made from recycled paper and should be disposed of at a waste-paper recycling collection location.

Disposal of Old Appliances

For environmental reasons, refrigeration appliances must be disposed of properly. This applies to your old appliance, and - at the end of its service life - for your new appliance as well.



Warning! Before disposing of old appliances make them inoperable. Remove plug from mains, sever the power cable, remove or destroy any snap or latch closures. This ensures that children do not lock themselves inside the appliance (danger of suffocation!) or place themselves into other life-endangering situations.

Disposal:

- The appliance may not be disposed of with domestic waste or bulky refuse.
- The refrigerant circuit, especially the heat exchanger at the back of the appliance, must not be damaged.
- The symbol  on the product or on its packaging indicates that this product may not be treated as household waste. Instead it shall be handed over to the applicable collection point for the recycling of electrical and electronic equipment. By ensuring this product is disposed of correctly, you will help prevent potential negative consequences for the environment and human health, which could otherwise be caused by inappropriate waste handling of this product. For more detailed information about recycling of this product, please contact your local city office, your household waste disposal service or the shop where you purchased the product.

Remove transport packaging

The appliance and the interior fittings are protected for transport.

-  1. Pull off the adhesive tape on the left and right side of the door.
2. Remove all adhesive tape and packing pieces from the interior of the appliance.

Installation

Installation Location

The appliance should be set up in a well ventilated, dry room.

Energy use and efficient performance of the appliance is affected by the ambient temperature.

The appliance should therefore

- not be exposed to direct sunlight;
- not be installed next to radiators, cookers or other sources of heat;
- only be installed at a location whose ambient temperature corresponds to the climate classification, for which the appliance is designed.

The climate classification can be found on the rating plate, which is located at the right on the inside of the appliance.

The following table shows which ambient temperature is correct for each climate classification:

Climate classification	for an ambient temperature of
SN	+10 to +32 °C
N	+16 to +32 °C
ST	+18 to +38 °C
T	+18 to +43 °C

Installation directly under a hob is not allowed. The temperatures of the hob, which in part are quite high, may damage the appliance.

If a hob is installed near the appliance, the corresponding installation and safety instructions must be adhered to. Considering the numerous installation conditions which are possible, there is no way of providing detailed information here.

It is necessary to avoid overheating of the refrigerator by maintaining adequate distances from heat sources and by the use of a suitable thermal insulation plate. Proper ventilation of the appliance must also be ensured.

Grid preparation

The side at which the door opens can be changed from the right side (as supplied) to the left side, if the installation site requires.



Warning! When changing the side at which the door opens, remove plug from the mains.

Left door opening:

1. Remove the left side (A) of the grid cutting it from the rear (see figure).
2. Remove the right side (B) of the grid cutting it from the rear (see figure).

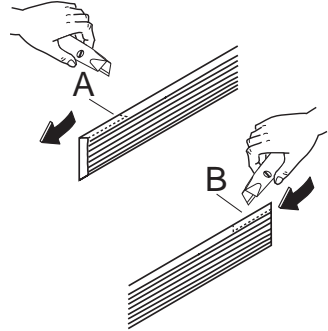

3. Re-install the grid to the base of the appliance by pushing on to the clasps (a) until they click.

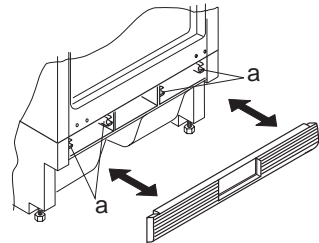

Reversing the door

The side at which the door opens can be changed from the right side (as supplied) to the left side, if the installation site requires.

To reverse the opening direction of the door, proceed as shown in the figures:

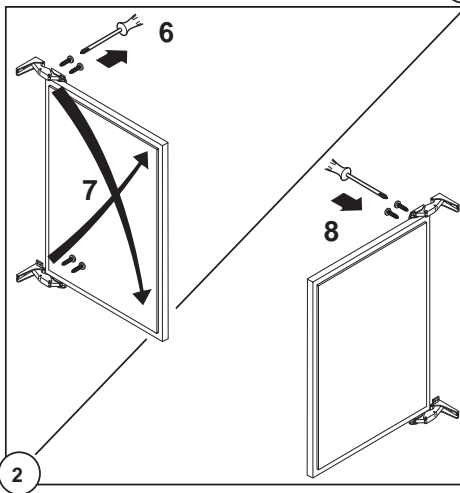
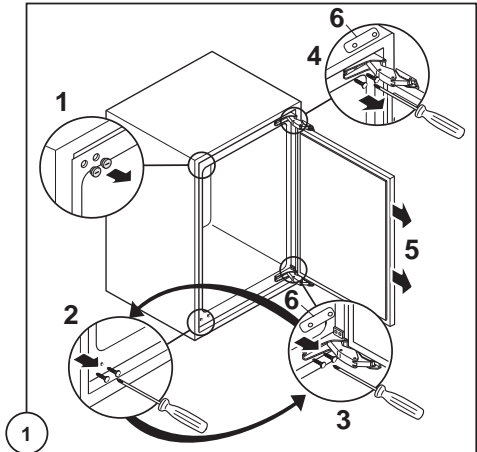

Warning! After completion of the door reversing operation, check that the door gasket adheres to the cabinet. If the ambient temperature is cold (i.e. in Winter), the gasket may not fit perfectly to the cabinet. In that case, wait for the natural fitting of the gasket or accelerate this process by heating up the part involved with a normal hairdryer on a low setting.

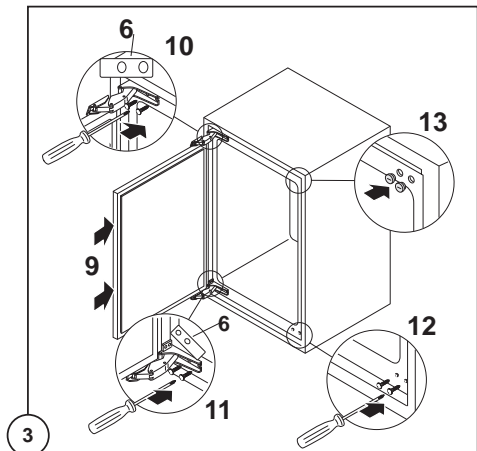

Building the appliance under a worktop

☞ The dimensions of the recessed installation area must correspond with those indicated in the figure.

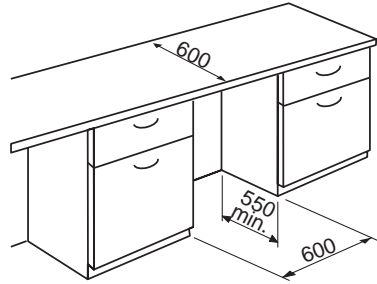

☞ Installation kit

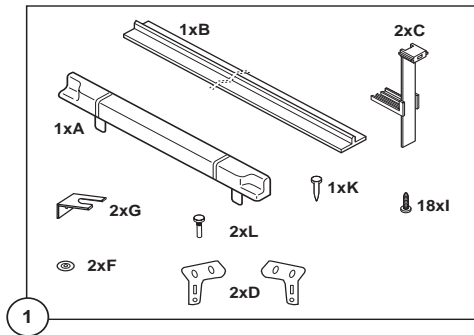

Two cabinet securing brackets are supplied with the installation pack. They need to be assembled onto the cabinet prior to cabinet being pushed into the Kitchen aperture.

☞ 1. To fit these brackets remove the two screws at the top left and right hand front corners of the cabinet.

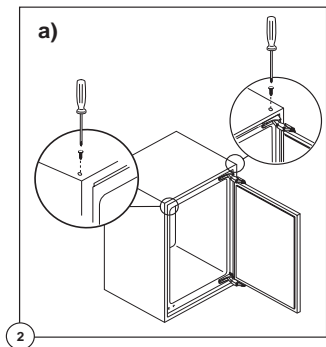

2. Position the two brackets as shown in the figure and replace the two securing screws.

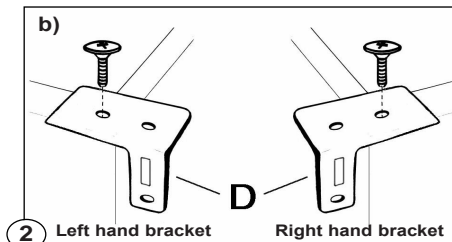

Push the appliance into place. The plug socket necessary for connection of the appliance to the electricity supply should be positioned, so that the plug is not placed in the recess.

3. To adjust the height proceed as follows:
Loosen or tighten the two front feet.

The rear feet are adjusted by turning the screw in the front kick plate to the left or right.

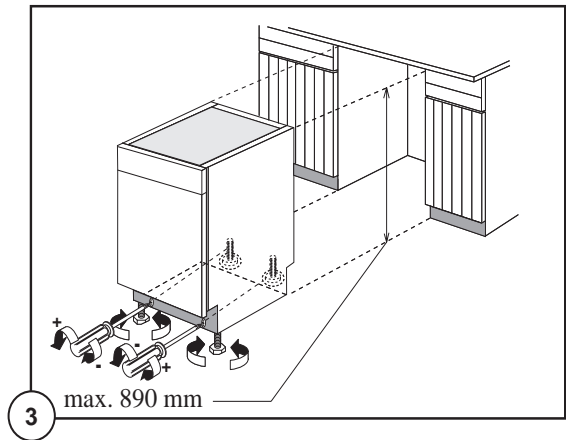

4. The joint cover (B) is to be assembled after having installed the appliance in the recess.

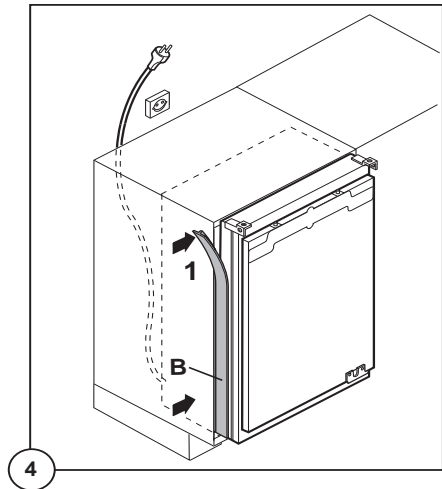

5. Push the appliance into place and retain the cabinet with screws (I) through the securing brackets into the worktop or adjacent woodwork as necessary.

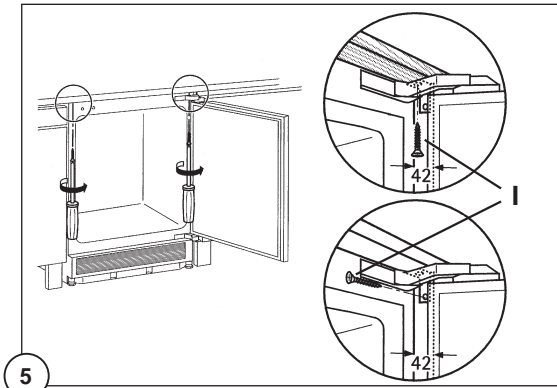

6. To mount the furniture door proceed as shown in the figures:

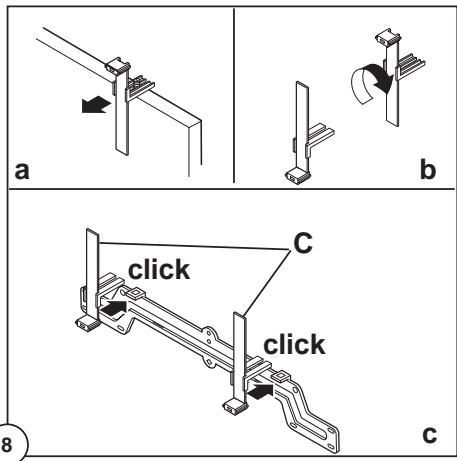
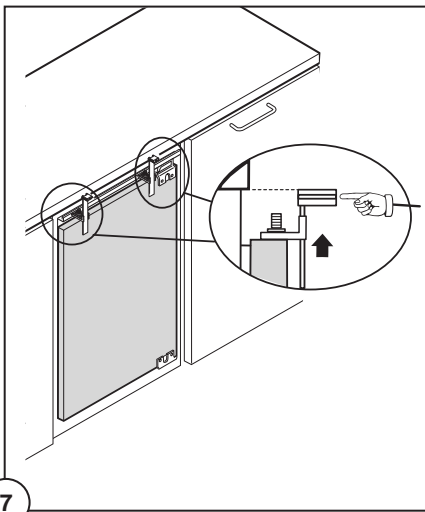
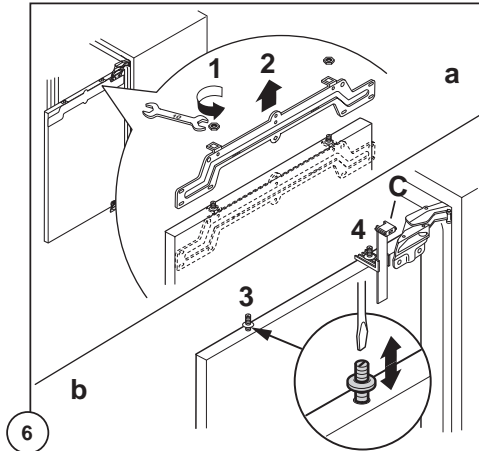

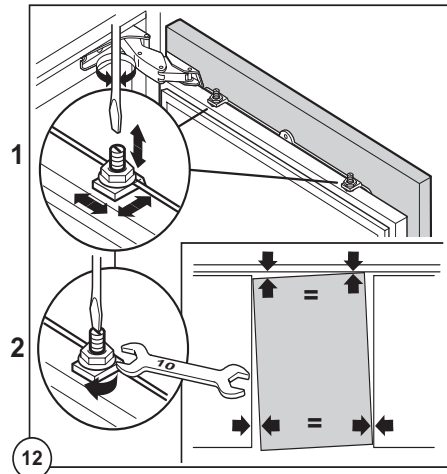
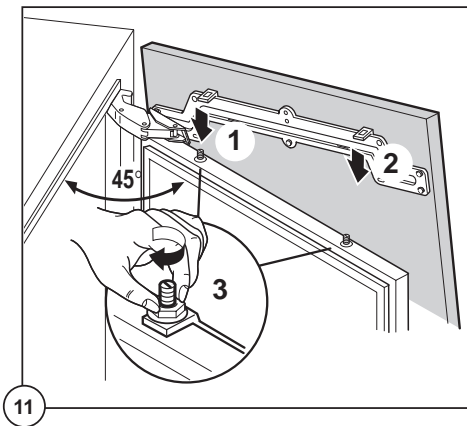
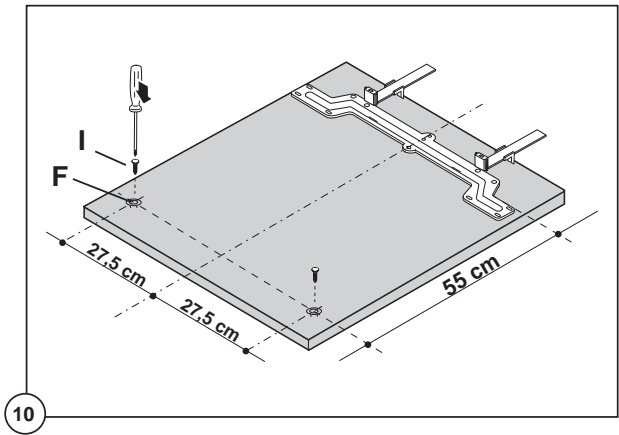
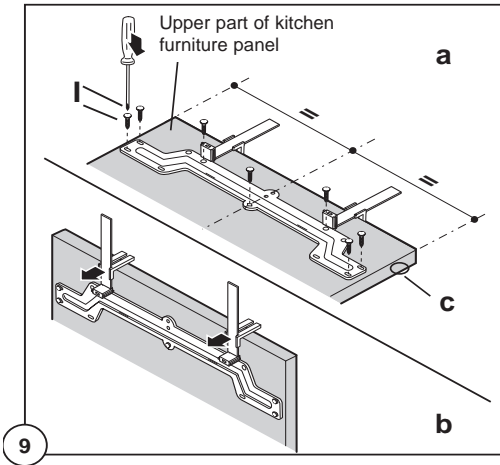

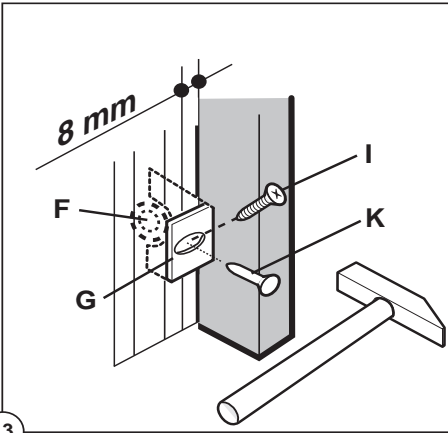

13

7. Refit the covering strip.

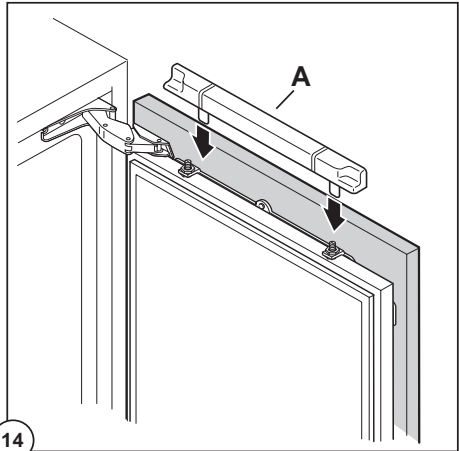

14

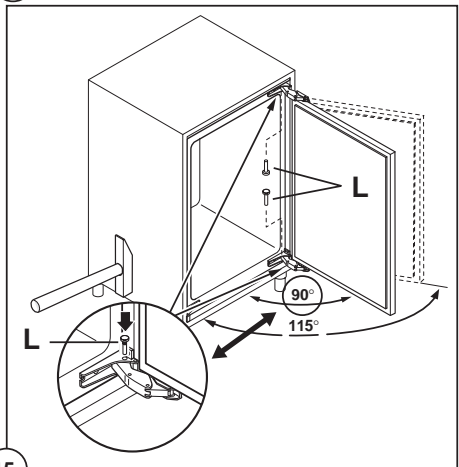

15

Fitting the plinth

Important!

For the efficient operation of the appliance, it is important that the original ventilation grid is used.

- For an opening height dimension $A=820$ mm and a plinth height dimension $a=100$ mm, the plinth may be fitted without adjustments. The same applies to an opening height dimension $B=890$ mm and a plinth height dimension $b=170$ mm.

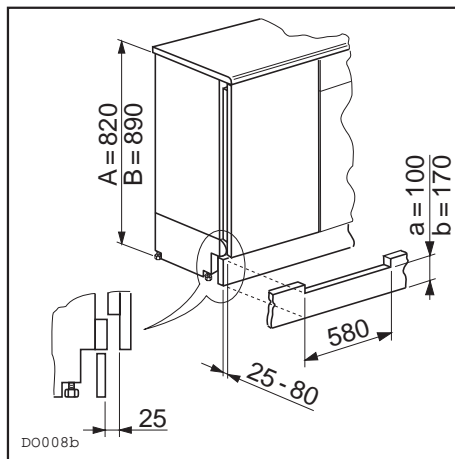

- For plinth heights greater than $a=100$ mm, $b=170$ mm, a cut should be made in the plinth, 580 mm wide, in the centre of the appliance position, leaving a remaining height of $a=100$ mm, $b=170$ mm.
- Attach plinth to the kitchen units.

Important!

The plinth must be positioned at a minimum distance of 25 mm from the door.

Please check whether, after installing your appliance and especially after reversing the door, the door seal seals right round. A badly fitting door seal may lead to heavy frosting and result in a higher power consumption (see also "What to do if ...").

Power supply

A correctly installed, earthed socket is required for the electrical supply. The supply must have a fuse rating of at least 10 Amps. If the socket is not accessible once the appliance is built in, the electrical installation must include suitable means of isolating the appliance from the mains (e.g. a fused spur).



Before initial start-up, refer to the appliance rating plate to ascertain if supply voltage and current values correspond with those of the mains at the installation location.

e.g.: AC 220 ... 240 V 50 Hz or
220 ... 240 V ~50 Hz

(i.e. 220 to 240 volts alternating current, 50 Hertz)

The rating plate is inside the appliance on the right.

The mains cable may only be changed by a qualified electrician or competent person. If your appliance needs repairing, please contact your local Service Force Centre.

Electrical Connection

Any electrical work required to install this appliance should be carried out by a qualified electrician or competent person.



WARNING – THIS APPLIANCE MUST BE EARTHED

The manufacturer declines any liability should these safety measures not be observed.

Before switching on, make sure the electricity supply voltage is the same as that indicated on the appliance rating plate. The rating plate is inside, on the right.

The appliance is supplied with a 13 amp plug fitted. In the event of having to change the fuse in the plug supplied, a 13 amp ASTA approved (BS 1362) fuse must be used.

Important

The wires in the mains lead are coloured in accordance with the following code:

Green and Yellow	Earth
Blue	Neutral
Brown	Live

As the colours of the wires in the mains lead of this appliance may not correspond with the coloured markings identifying the terminals in your plug, proceed as follows:

1. The wire coloured green and yellow must be connected to the terminal marked with the letter "E" or by the earth symbol \oplus or coloured green and yellow.
2. The wire coloured blue must be connected to the terminal marked "N" or coloured black.
3. The wire coloured brown must be connected to the terminal marked "L" or coloured red.
4. Upon completion there must be no cut, or stray strands of wire present and the cord clamp must be secure over the outer sheath.

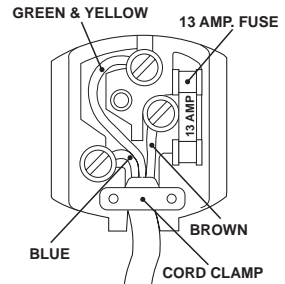

Warning! A cut-off plug inserted into a 13 amp socket is a serious safety (shock) hazard. Ensure that the cut-off plug is disposed of safely.

Description of the appliance

View of the appliance

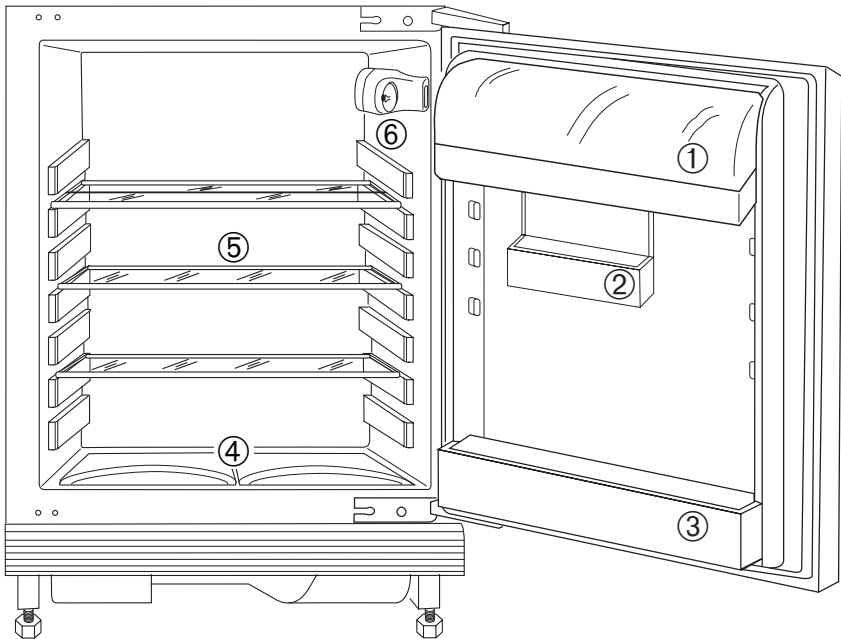

- 1 Butter/cheese compartment
- 2 Sliding shelf
- 3 Bottle shelf
- 4 Vegetable drawers
- 5 Storage shelves
- 6 Thermostat

Prior to Initial Start-Up

 Please clean the appliance interior and all accessories prior to initial start-up (see section: "Cleaning and Care").

Starting up and temperature regulation

Important! Only use the appliance when built-in!

1. Connect the appliance to the mains electricity supply.
When the refrigerator compartment door is opened, the internal lighting is switched on.

The temperature control knob is located on the right hand side of the refrigerator compartment.

Setting "0" means: Off.

2. Turn the control knob clockwise past "1". The refrigerating unit is now on and operates automatically.

Setting "1" means:

Highest temperature, warmest setting.

Setting "6" (end-stop) means:

Lowest temperature, coldest setting.



Note: From a food safety point of view +5 °C should be considered sufficiently cold for storing food in the fridge.

At a low ambient temperature of around 16°C, setting "1" should be selected. At ambient temperatures of around 25°C, select setting "2". If you require a lower temperature, select setting "3" or "4".

Important!

High ambient temperatures (e.g. on hot summer days) and a cold setting on the thermostat (position "5" to "6") can cause the compressor to run continuously.

Reason: when the ambient temperature is high, the compressor must run continuously to maintain the low temperature in the appliance. The fridge will not be able to defrost since automatic defrosting of the fridge is only possible when the compressor is not running (see also "Defrosting" section). The result is the build up of a thick layer of frost on the fridge rear wall.

If this happens, turn the thermostat knob back to a warmer setting (position "3" to "4"). At this setting the compressor will be switched on and off as usual and automatic defrosting recommenced.

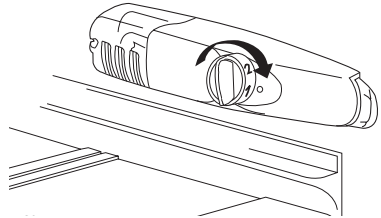

Switching off the appliance

☞ To switch off the appliance, turn the temperature regulator to position "0".

If the appliance is not going to be used for an extended period:

- ☞ 1. Remove all refrigerated packages.
2. Switch off the appliance by turning the thermostat knob to position "0".
3. Remove the mains plug or switch off or disconnect from the electricity supply.
4. Clean thoroughly (see section: "Cleaning and Care").
5. Leave the door open to avoid the build up of odours.

Interior Accessories

Storage shelves

Various glass storage shelves are included with your appliance.

The height of the storage shelves can be adjusted:

- ☞ 1. To do this pull the storage shelf forward until it can be swivelled upwards or downwards and removed.
2. Please do the same in reverse to insert the shelf at a different height.

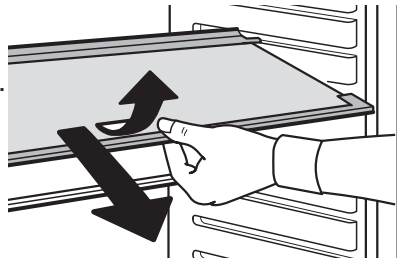

Your appliance is equipped with two half size glass storage shelves.

Storing tall items:

- ☞ Slide the front half of the Vario storage shelf in another level to the rear. By this means you will gain space to place tall items on the storage shelf below.

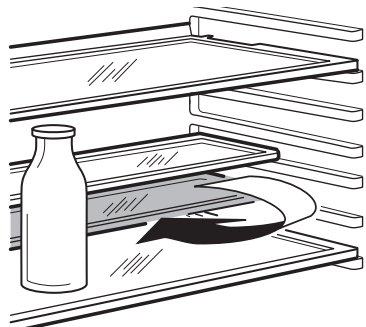

Variable Storage Box

Some models are equipped with a variable storage box which is fitted under a door shelf compartment and can be slid sideways.

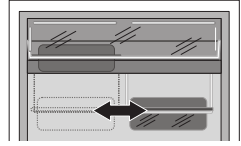

The variable box can be hung from a storage shelf in the refrigerator compartment:

1. Pull the storage shelf forward until it can be tipped up or down and removed.
2. Hang the retaining bracket on the taper on the storage shelf and slide the storage shelf back into the guides.

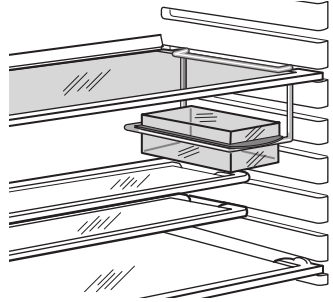

Bottle Holder

Some models are equipped with a bottle holder in the bottle compartment. This is used to prevent individual bottles from falling over and can be slid sideways.

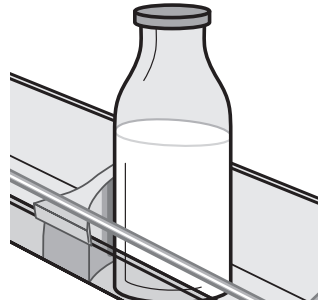

Correct storage

For physical reasons, there are different temperature regions in the fridge. The coldest region is on the lowest storage shelf.

Warmer regions are the top storage shelf, the vegetable drawer and the storage compartments on the door. The arrangement example shows at which places in the refrigerator suitable temperatures for various types of foods exist.

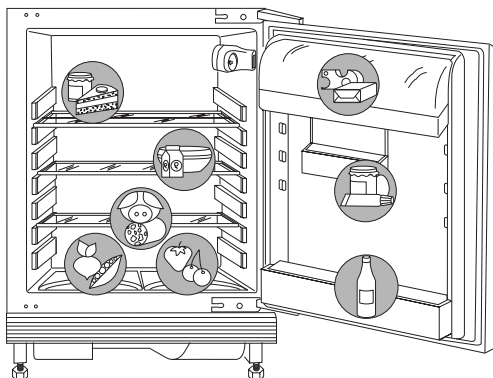

Tip: Food in the fridge should always be covered or packaged, to prevent drying and tainting of other food.

The following are suited for packaging:

- Polyethylene airtight bags and wraps;
- Plastic containers with lids;
- Special plastic covers with elastic;
- aluminium foil.

Defrosting

The fridge defrosts automatically

The rear wall of the fridge covers with frost when the compressor is running, and defrosts when the compressor is off. The water from the thawing frost evaporates by itself.

Cleaning and Care

For hygienic reasons the appliance interior, including interior accessories, should be cleaned regularly.



Warning!

- The appliance must not be connected to the mains during cleaning. Danger of electrical shock. Before cleaning switch the appliance off and remove the plug from the mains, or disconnect from the electricity supply.
- Never clean the appliance with a steam cleaner. Moisture could accumulate in electrical components and there is a danger of an electrical shock. Hot vapours can lead to the damage of plastic parts.
- The appliance must be dry before it is placed back into service.

Important!

- Ethereal oils and organic solvents can attack plastic parts, e.g.
 - lemon juice or the juice from orange peals;
 - butyric acid;
 - cleansers which contain acetic acid.Do not allow such substances to come into contact with appliance parts.
- Do not use any abrasive cleansers.



1. Remove the food from the refrigerator. Store it in a cool place, well covered.
2. Switch the appliance off and remove the plug from the mains, or disconnect from the electricity supply
3. Clean the appliance and the interior accessories with a cloth and luke-warm water.
4. After cleaning wipe with fresh water and rub dry.
5. Check the water drain hole (F) under the vegetable drawers of the fridge is not blocked. Clear a blocked drain hole with the aid of the green peg (P) in the pack of accessories included with the appliance.
6. After everything is dry place appliance back into service.

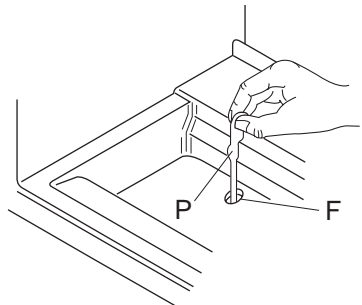



An accumulation of dust will affect the performance of the appliance and cause excessive electricity consumption. The structure of the appliance permits you to clean the rear zone close to the wall, using a vacuum cleaner.

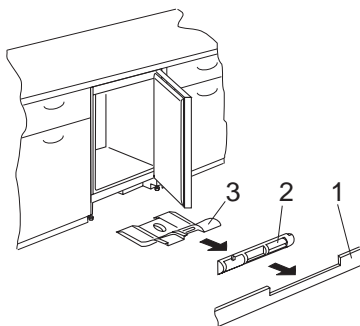

1. Remove the plinth (1), then the ventilation grid (2);
2. Carefully pull the air deflector out (3), checking that there is no water left from the defrosting.



Energy Saving Tips

- Do not install the appliance near boilers, radiators or other sources of heat. High ambient temperatures cause longer, more frequent operation of the compressor.
- Ensure sufficient air circulation and exhaust at the appliance base and at the back wall of the appliance. Never cover air vent openings.
- Do not place warm foods into the appliance. Allow warm foods to cool first.
- Do not leave the door open any longer than necessary.
- Do not set temperature any colder than necessary.

What to do if ...

Correcting Malfunctions

A malfunction may be caused by only a minor fault that you can rectify yourself using the following instructions. Do not perform any other work on the appliance if the following information does not provide assistance in your specific case.



Important! Repairs to refrigerators/freezers may only be performed by competent service engineers. Improper repairs can give rise to significant hazards for the user. If your appliance needs repairing, please contact your specialist dealer or your local Service Force Centre.

Symptom	Possible Cause	Remedy
Appliance does not work.	Appliance is not switched on.	Switch on the appliance.
	Mains plug is not plugged in or is loose.	Insert mains plug.
	Fuse has blown or is defective	Check fuse, replace if necessary.
	Socket is defective.	Mains malfunctions are to be corrected by an electrician.
The compressor runs continuously.	Temperature is set too cold.	Turn the thermostat knob to a warmer setting temporarily.
Interior lighting does not work.	Light bulb is defective.	Please look in the "Changing the Light Bulb" section.
The food is too warm.	Temperature is not properly adjusted.	Please look in the "Initial Start Up" section.
	Door was open for an extended period.	Do not leave the door open any longer than necessary.
	A large quantity of warm food was placed in the appliance within the last 24 hours.	Turn the thermostat knob to a colder setting temporarily.
	The appliance is near a heat source.	Please look in the "Installation location" section.
Heavy build up of frost, possibly also on the door seal.	Door seal is not airtight (possibly after reversing the door).	Carefully warm the leaking sections of the door seal with a hair dryer (on a cool setting). At the same time shape the warmed door seal by hand such that it sits correctly.
The compressor does not start immediately after changing the temperature setting.	This is normal, no error has occurred.	The compressor starts after a period of time.
Water in the bottom of the cabinet.	Water drain hole is blocked.	See the "Cleaning and Care" section.

Changing the light bulb



Warning! There is a risk of electric shocks! Before changing the light bulb, switch off the appliance and unplug it, or disconnect from the power supply.

Light bulb data: 230–240 V, max. 15 W

1. To switch off the appliance, turn the thermostat knob to position "0".
2. Unplug the mains plug.
3. To change the light bulb, undo the screw.
4. Press the light bulb cover as shown and slide it backwards.
5. Change the defective light bulb.
6. Refit the light bulb cover and the screw.
7. Put the refrigerator back into operation.

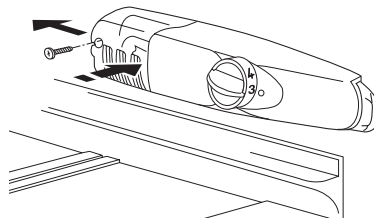

Noises during Operation

The following noises are characteristic of refrigeration appliances:

- **Clicks**
Whenever the compressor switches on or off, a click can be heard.
- **Humming**
As soon as the compressor is in operation, you can hear it humming.
- **Bubbling/Splashing**
When refrigerant flows into thin tubes, you can hear bubbling or splashing noises. Even after the compressor has been switched off, this noise can be heard for a short time.

Regulations, Standards, Guidelines

This appliance was designed for household use and was manufactured in accordance with the appropriate standards. The necessary measures in accordance with appliance safety legislation regulations (GSG), accident prevention regulations for refrigeration appliances (VBG 20) and the regulations of the German Society of Electrical Engineers (VDE)

were observed in the manufacture of this appliance.
The refrigerant circuit has been checked for leaks.

CE This appliance is in accordance with the following EU guidelines:

- 73/23/EEG dated 19 February 1973 - low voltage guidelines.
- 89/336/EEG dated 3 May 1989
(including guideline change notice 92/31/EEG) - EMV guideline

Technical terminology

- **Refrigerant**

Liquids that can be used to generate a cooling effect are known as refrigerants. They have a relatively low boiling-point, indeed so low, that the warmth from the food stored in the fridge or freezer can cause the refrigerant to boil and vaporise.

- **Refrigerant Circuit**

Closed circulation system that contains the refrigerant. The refrigerant circuit comprises primarily of an evaporator, a compressor, a condenser and pipe work.

- **Evaporator**

The refrigerant is evaporated in the evaporator. Similar to all other liquids, refrigerant requires heat to evaporate. This heat is removed from the interior of the appliance, as a result the interior is cooled. The evaporator is therefore located inside the appliance or placed in foam immediately behind the inner wall and thus not visible.

- **Compressor**

The compressor looks like a small drum. It is driven by a built-in electric motor and is mounted on the base of the appliance at the rear. The task of the compressor is to draw in vaporised refrigerant from the evaporator, to compress it, and to pass it on to the condenser.

- **Condenser**

The condenser normally has the form of a grid. The refrigerant compressed in the compressor is liquefied in the condenser. During this process, heat is released to the surrounding air at the surface of the condenser. The condenser is mounted on the base of the appliance.

AEG Hausgeräte GmbH

Postfach 1036

D-90327 Nürnberg

Sie können Ersatzteile, Zubehör und Pflegemittel on-line bestellen bei

<http://www.aeg-electrolux.de>

© Copyright by AEG

Technische Änderungen vorbehalten

211620001- 00 - 1809